

User Manual

MASTER-K

**K200S
K300S
K1000S**

Programmable Logic Controller



Safety Instructions

- Read this manual carefully before installing, wiring, operating, servicing or inspecting this equipment.
- Keep this manual within easy reach for quick reference.

Chapter 1 Introduction

1	Introduction.....	1-1
1.1	Guide to the user's manual.....	1-1
1.2	Features.....	1-2
1.3	Terminology.....	1-3

1 Introduction

1.1 Guide to the user's manual

This user's manual contains specifications, performance, and handling instructions for each of unit of MASTER-K 200S/300S/1000S series PLC system.

The following table shows the configuration of this user's manual.

Chapter	Item	Description
1	Instruction	Describes configuration of this manual, modules features and terminology.
2	System configuration	Describes available modules and system configurations in the MASTER-K200S/300S/1000S series.
3	Specifications	Describes general specifications of various modules used in the MASTER-K200S/300S/1000S series.
4	CPU module	Describes the performance, specifications and functions of the CPU module.
5	Battery	Describes the specifications and handling instructions for other modules except for the CPU module.
6	Memory module	
7	Digital I/O module	
8	Power supply module	
9	Base and cable	
10	Installation and wiring	Describes installation, wiring and handling instructions for reliability of the PLC system.
11	Maintenance	Describes the check point and method for maintenance of the PLC system.
12	Troubleshooting	Describes various operation errors and corrective actions.
13	RS232C communication for K200S	Describes the RS-232C communication function of K200S A and C type
14	RS422 communication for K200S	Describes the RS422 communication functions of K200S B type
15	PID function of K200S	Describes the PID control function of K200S B and C type
16	High speed counter of K200S	Describes the HSC function of K200S C type
Appendix 1	Flag list	Describes types and contents of various flags
Appendix 2	Dimension	Shows dimensions of CPU, I/O modules and base unit

Remark

In this manual, it is not described that the hardware information and programming of special/communication modules. Please refer the user's manual of each module for details.

1.2 Features

The features of MASTER-K 200S/300S/1000S series are as following;

- 1) Program compatibility with previous MASTER-K series
- 2) Support various and easy-to-use programming devices
 - ① KGL-WIN : Graphic loader for Windows 95 / 98
 - ② KLD-150S : Hand-held loader
- 3) Open network by supporting communication protocol complying with international standard.
- 4) Fast processing speed (operation dedicated processor is mounted)
 - ① K200S : 0.5 μ sec / step
 - ② K300S / K1000S : 0.2 μ sec / step
- 5) Various special modules that enlarge the application range of PLC
- 6) Enhanced self-diagnosis functions

The MASTER-K 200S/300S/1000S series provides more detail error codes that make the cause of error can be found more easily.

- 7) Debug function

On-line debugging is available by changing the operation mode as RUN \rightarrow Debug. The MASTER-K 200S/300S/1000S series provides following debugging functions;

- ① Execution by one instruction
 - ② Execution by break point setting
 - ③ Execution by the device status
 - ④ Execution by specified scan times
- 8) Various program types

The MASTER-K 200S/300S/1000S series supports various program types such as time-driven interrupt (TDI), process-driven interrupt (PDI), and subroutine program.

1.3 Terminology

The following table shows the definition of terms used in this manual.

Terms	Definition	Remark
Module	A standard element that has a specified function which configures a system. Devices such as CPU or I/O, which mounted on the base board or base unit.	Example) CPU module, Power module, I/O module, etc.
Unit	A single module or group of modules that performs an independent operation as a part of PLC system.	Example) main unit, expansion unit
PLC system	A system that consists of PLC and peripheral devices that are controlled by user program.	
KGL-WIN	A computer software for Windows 95 / 98 used for write, editing, and debugging of user program of MASTER-K series.	
KLD-150S	A hand-held loader used for write, editing, and debugging of user program of MASTER- K series	
I/O image area	Internal memory area of CPU module that holds the I/O status during PLC operation.	
FAM	Abbreviation of the 'Factory Automation Monitoring S/W'. It is used to call software for process supervision.	
Fnet	Fieldbus network	
Cnet	Computer network (RS-232C, RS-422/485)	
Pnet	ProfiBus Network	
Enet	Ethernet Network	
RTC	Abbreviation of 'Real Time Clock'. It is used to call general ICs that contains clock function.	
Watchdog timer	An internal timer used for supervising program execution time. It gives a warning when the execution time exceeds the preset time.	

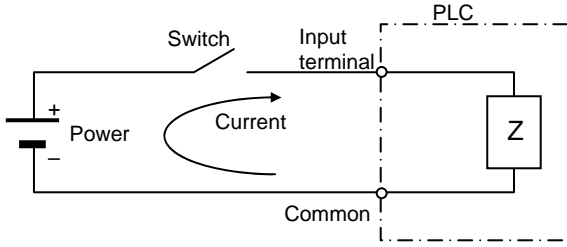
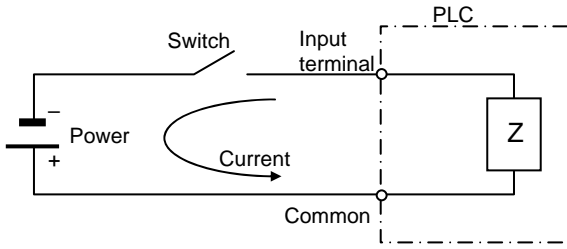
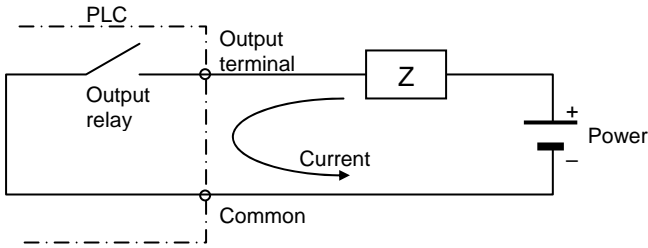
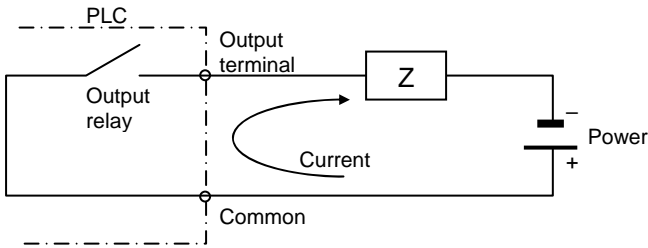
Terms	Definition	Remark
Sink input	<p>Current flows in from the input switch to the input terminal of PLC when an input signal is turned on.</p> 	Z: Input impedance
Source input	<p>Current flows out from the input terminal of PLC to the input switch when an input signal is turned on.</p> 	
Sink output	<p>Current flows in from the external load to the output terminal of PLC when an output signal is turned on.</p> 	
Source output	<p>Current flows out from the output terminal of PLC to the external load when an output signal is turned on.</p> 	

Chapter 2 System configuration

2 System configuration	2-1
2.1 Overall configuration.....	2-1
2.1.1 K200S series.....	2-1
2.1.2 K300S / 1000S series	2-2
2.2 Product list	2-3
2.2.1 K200S	2-3
2.2.2 K300S	2-5
2.2.3 K1000S	2-8
2.3 System configuration types.....	2-11
2.3.1 Basic system configuration	2-11
2.3.2 Computer link system	2-12
2.3.3 Network system	2-13

2 System configuration

The MASTER-K 200S/300S/1000S series has various modules suitable to configuration from the basic to a large network system. This chapter describes the configuration and features of each systems.

2.1 Overall configuration

2.1.1 K200S series

The overall system configuration of K200S series is as following;

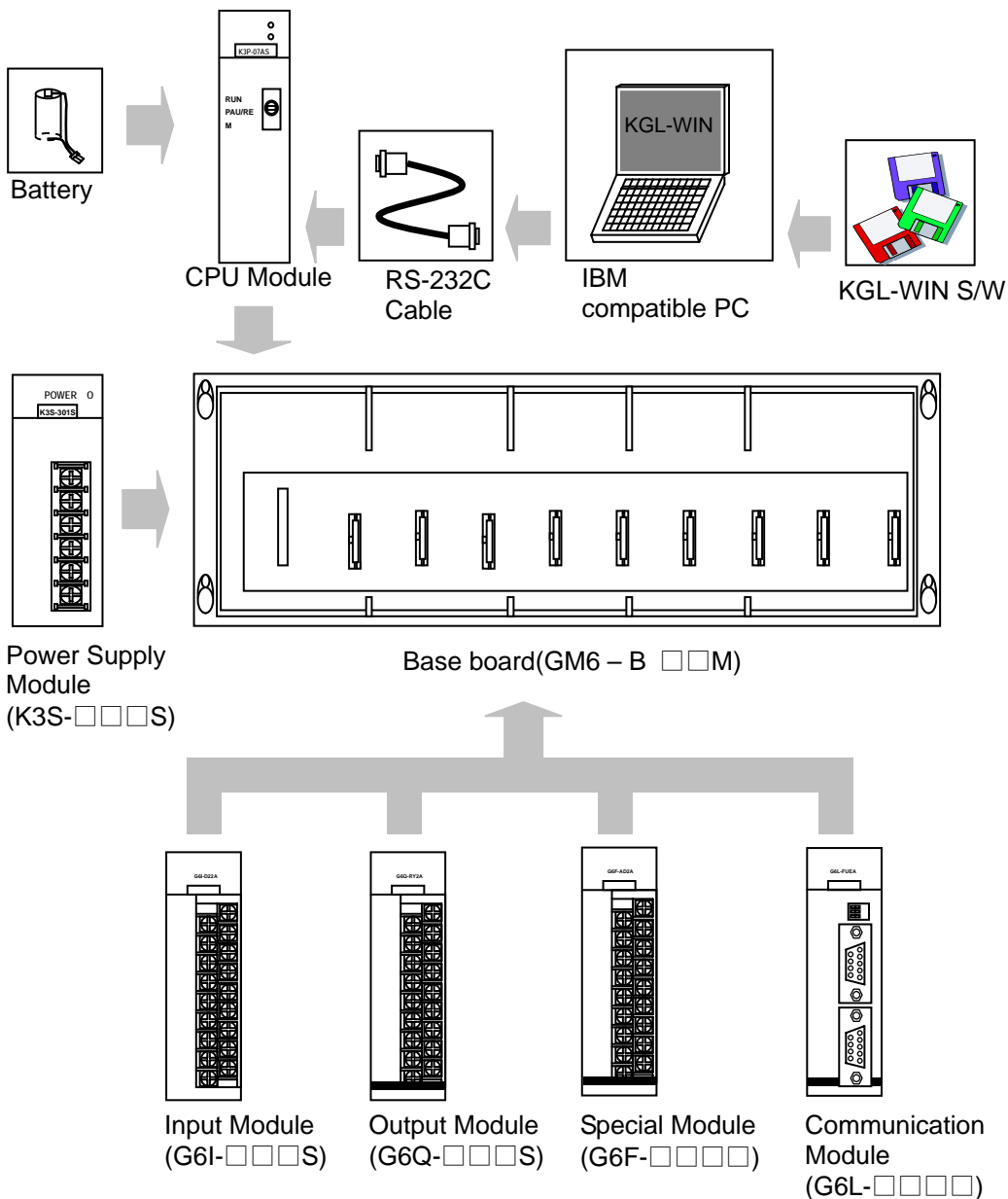

2.1.2 K300S / 1000S series

The overall system configuration of K300S/1000S series is as following;

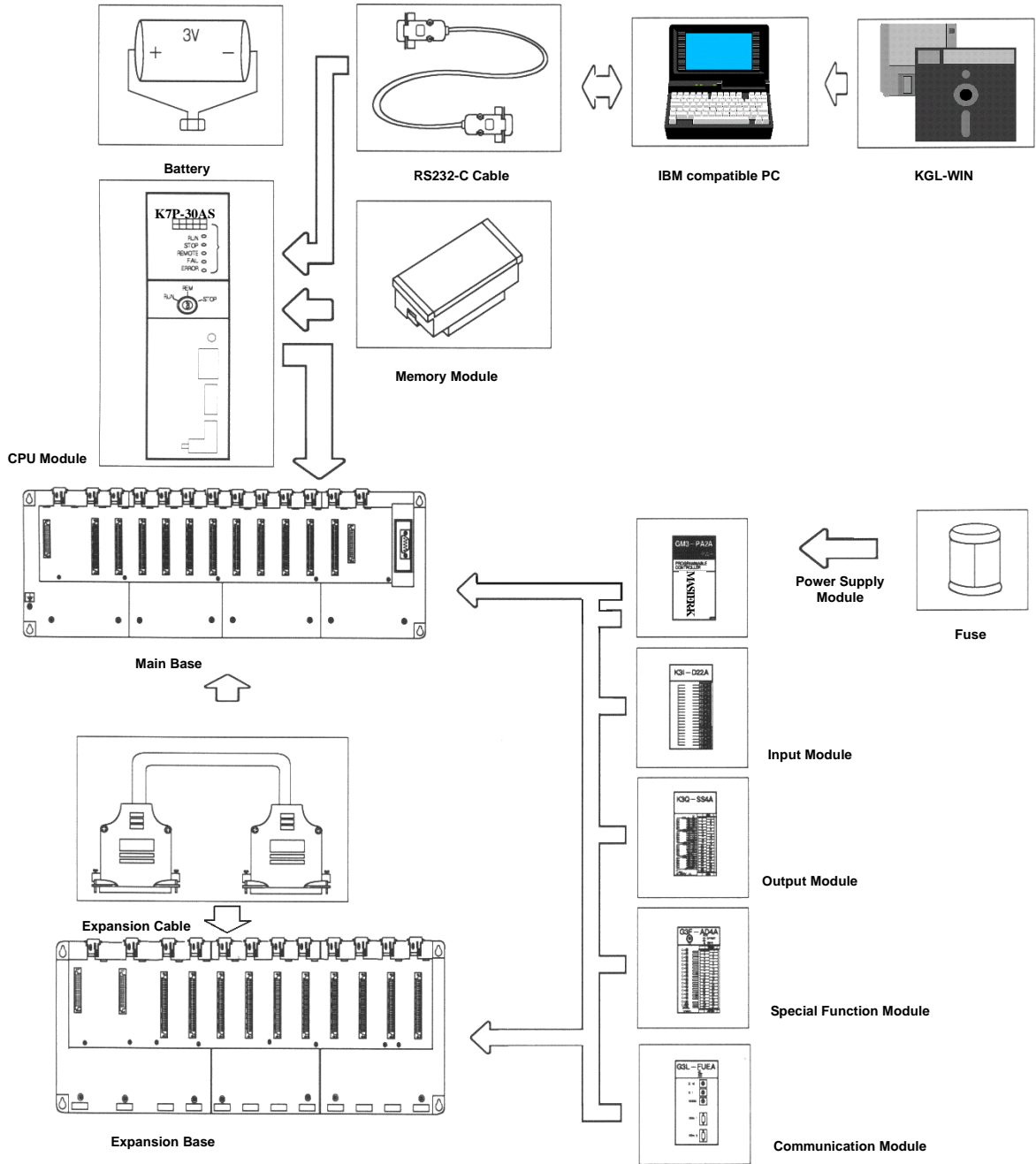

2.2 Product list

The product list of K200S/300S/1000S are as following;

2.2.1 K200S

Items	Model No.	Description	Remark	
CPU modules	K3P-07AS	Max. I/O points : 512 points Special functions : RS-232C		
	K3P-07BS	Max. I/O points : 512 points Special functions : RS-422/485, RTC, PID control		
	K3P-07CS	Max. I/O points : 512 points Special functions : RS-232C, RTC, HSC, PID control		
Digital input modules	G6I-D21A	12/24VDC input, 8 points (source/sink)		
	G6I-D22A	12/24VDC input, 16 points (source/sink)		
	G6I-D22B	24VDC input, 16 points (source)		
	G6I-D24A	12/24VDC input, 32 points (source/sink)		
	G6I-D24B	24VDC input, 32 points (source)		
	G6I-A11A	110VAC input, 8 points		
	G6I-A21A	220VAC input, 8 points		
Digital output modules	G6Q-RY1A	Relay output, 8 points, 2A/point	1points/com	
	G6Q-RY2A	Relay output, 16 points, 2A/point		
	G6Q-TR2A	Transistor output, 16 points, 0.5A/point (sink)		
	G6Q-TR2B	Transistor output, 16 points, 0.5A/point (source)		
	G6Q-TR4A	Transistor output, 32 points, 0.1A/point (sink)		
	G6Q-TR4B	Transistor output, 32 points, 0.1A/point (source)		
	G6Q-SS1A	Triac output, 16 points, 1A/point		
Digital I/O hybrid module	G6H-DR2A	12/24VDC input, 8 points (source/sink) Relay output, 8 points, 2A/point		
Main bases	GM6-B04M	4 module		
	GM6-B06M	6 module		
	GM6-B08M	8 module		
	GM6-B12M	12 module		
Power supply modules	GM6-PAFA	100 ~ 240VAC	5VDC (2A), 24VDC (0.3A)	
	GM6-PAFB		5VDC (2A), +15VDC (0.5A), -15VDC (0.2A)	
	GM6-PAFC		5VDC (3.5A), 24VDC (0.3A)	
	GM6-PDFA	12 ~ 24VDC	5VDC (2A)	
	GM6-PDFB		5VDC (3A), +15VDC (0.5A), -15VDC (0.2A)	

(continued)

	Items	Model No.	Description	Remark
Special modules	A/D conversion modules	G6F-AD2A	Voltage / Current input, 4channels 1 ~ 5VDC / 0 ~ 10VDC / -10 ~ 10VDC DC 4 ~ 20mA	
	D/A conversion modules	G6F-DA2V	Voltage output, 4 channels -10 ~ 10VDC	
		G6F-DA2I	Current output, 4 channels DC 4 ~ 20mA	
	High speed counter module	G6F-HSCA	Counting range (0 ~ 16,777,215 : binary 24 bits) 50kHz, 1 channel	
	Positioning module	G6F-POPA	Pulse output, 2 axes control	
	Thermocouple module	G6F-TC2A	Sensor type : 7 types (K, J, E, T, B, R, S) Input channel : 4 channels	
Network modules	Fnet modules	G6L-FUEA	Fnet I/F module 1Mbps base band, Twisted pair cable	
		G6L-RBEA	Fnet remote I/F module 1Mbps base band, Twisted pair cable	
	Cnet modules	G6L-CU2A	Cnet I/F module (RS-232C)	
		G6L-CU4A	Cnet I/F module (RS-422/485)	
	DeviceNet module	G6L-DUEA	DeviceNet I/F module	
	ProfiBus module	G6L-PUEA	ProfiBus I/F module	
		G6L-PUEB	ProfiBus I/F module	
Dust-cover	GM6-DMMA	Dust-protector for unused slot		

2.2.2 K300S

Items	Model No.	Description	Remark
CPU modules	K4P-15AS	Max. I/O points : 512 points	
Digital input modules	G4I-D22A	12/24VDC input, 16 points (source/sink)	
	G4I-D22B	12/24VDC input, 16 points (source)	
	G4I-D22C	24VDC input, 16 points (source/sink)	
	G4I-D24A	12/24VDC input, 32 points (source/sink)	
	G4I-D24B	12/24VDC input, 32 points (source)	
	G4I-D24C	24VDC input, 32 points (source/sink)	
	G4I-D28A	12/24VDC input, 64 points (source/sink)	
	G4I-A12A	110VAC input, 16 points	
	G4I-A22A	220VAC input, 16 points	
Digital output modules	G4Q-RY2A	Relay output, 16 points, 2A/point	
	G4Q-TR2A	Transistor output, 16 points, 0.5A/point (sink)	
	G4Q-TR2B	Transistor output, 16 points, 0.5A/point (source)	
	G4Q-TR4A	Transistor output, 32 points, 0.1A/point (sink)	
	G4Q-TR4B	Transistor output, 32 points, 0.1A/point (source)	
	G4Q-TR8A	Transistor output, 64 points, 0.1A/point (sink)	
	G4Q-SS2A	Triac output, 16 points, 1A/point	
	G4Q-SS2B	Triac output, 16 points, 0.6A/point	
Main base boards	GM4-B04M	4 module	
	GM4-B06M	6 module	
	GM4-B08M	8 module	
	GM4-B12M	12 modules	No expansion
Expansion base boards	GM4-B04E	4 modules	
	GM4-B06E	6 modules	
	GM4-B08E	8 modules	
Expansion cables	G4C-E041	Length : 0.4m	
	G4C-E121	Length : 1.2m	
	G4C-E301	Length : 3.0m	
Memory module	GM4-M032	Flash memory, 32k steps	
Power supply modules	GM4-PA1A	110VAC	5VDC : 5A, 24VDC : 0.7A
	GM4-PA2A	220VAC	
	GM4-PA1B	110VAC	5VDC : 3A, 24VDC : 0.5A,
	GM4-PA2B	220VAC	
	GM4-PD3A	24VDC	5VDC : 4A, 24VDC : bypass

(continued)

	Items	Model No.	Description	Remark
Special modules	A/D conversion modules	G4F-AD2A	Voltage / Current input, 4channels -5 ~ 5VDC / -10 ~ 10VDC DC -20 ~ 20mA	
		G4F-AD3A	Voltage / Current input, 8channels 1 ~ 5VDC / 0 ~ 10VDC DC 4 ~ 20mA	
	D/A conversion modules	G4F-DA1A	Voltage / Current output, 2 channels -10 ~ 10VDC, DC4 ~ 20mA	
		G4F-DA2V	Voltage output, 4 channels -10 ~ 10VDC	
		G4F-DA2I	Current output, 4 channels DC 4 ~ 20mA	
		G4F-DA3V	Voltage output, 8 channels -10 ~ 10VDC	
		G4F-DA3I	Current output, 8 channels DC 4 ~ 20mA	
	High speed counter module	G4F-HSCA	Counting range (0 ~ 16,777,215 : binary 24 bits) 50kHz, 1 channel	
	Positioning module	G4F-POPA	Pulse output, 1 axis control	
		G4F-POPB	Pulse output, 2 axes control	
	Thermocouple input module	G4F-TC2A	Sensor type : 7 types (K, J, E, T, B, R, S) 4 channels	
	RTD module	G4F-RD2A	Sensor type : Pt100, JPt100 4 channels	
	PID control module	G4F-PIDA	Max. 8 loops control	
	Analog timer module	G4F-AT3A	8 analog timers Setting range : 0.1 ~ 1.0sec / 1 ~ 10sec 10 ~ 60sec / 60 ~ 600sec	Each channel can be set independently
Interrupt module	G4F-INTA	8 channels		

(continued)

	Items	Model No.	Description	Remark
Network modules	Fnet modules	G4L-FUEA	Fnet I/F module 1Mbps base band, Twisted pair cable	
		G0L-FUEA	Fnet I/F module 1Mbps base band, Twisted pair cable	Install to the IBM compatible PC
		G4L-RBEA	Fnet remote I/F module 1Mbps base band, Twisted pair cable	
		G0L-SMIA	Fnet single I/F module 12 / 24VDC input, 16 points	
		G0L-SMQA	Fnet single I/F module Relay output, 1A/point, 16 points	
		G0L-SMHA	Fnet single I/F module 12 / 24VDC input, 8 points Relay output, 1A/point, 16 points	
		G0L-FREA	Repeater for Fnet	
	Converter	G0L-FOEA	Optical ↔ Electrical converter	
	Active coupler	G0L-FAPA	Power module for active coupler	
		G0L-FABA	Base board for active coupler	
		G0L-FACA	Active coupler	
		G0L-FADA	Dummy card for active coupler	
	Cnet modules	G4L-CUEA	Cnet I/F module (RS-232C)	
	DeviceNet I/F module	G4L-DUEA	DeviceNet I/F module	In 3.0 or higher CPU O/S version and 3.2 or higher KGL-WIN version
Profibus-DP I/F module	G4L-PUEA	Profibus-DP master module (I/O : 1K)		
	G4L-PUEB	Profibus-DP master module (I/O : 7K)		
Others	Pseudo input switch	G4S-SW16	Pseudo input switch, 16 points	
	Dust cover	GM4-DMMA	Dust protector for unused slot	

2.2.3 K1000S

Items	Model No.	Description	Remark
CPU modules	K7P-30AS	Max. I/O points : 1,024 points	
Digital input modules	G3I-D22A	12/24VDC input, 16 points (source/sink)	
	G3I-D24A	12/24VDC input, 32 points (source/sink)	
	G3I-D24C	24VDC input, 32 points (source/sink)	
	G3I-D28A	12/24VDC input, 64 points (source/sink)	
	G3I-A12A	110VAC input, 16 points	
	G3I-A22A	220VAC input, 16 points	
	G3I-A14A	110VAC input, 32 points	
	G3I-A24A	220VAC input, 32 points	
Digital output modules	G3Q-RY2A	Relay output, 16 points, 2A/point	
	G3Q-RY4A	Relay output, 32 points, 1A/point	
	G3Q-TR2A	Transistor output, 16 points, 2A/point (sink)	
	G3Q-TR4A	Transistor output, 32 points, 0.5A/point (sink)	
	G3Q-TR4B	Transistor output, 32 points, 0.5A/point (source)	
	G3Q-TR8A	Transistor output, 64 points, 0.1A/point (sink)	
	G3Q-TR8B	Transistor output, 64 points, 0.1A/point (source)	
	G3Q-SS2A	Triac output, 16 points, 2A/point	
	G3Q-SS4A	Triac output, 32 points, 1A/point	
Main base boards	GM3-B04M	4 module	
	GM3-B06M	6 module	
	GM3-B08M	8 module	
Expansion base boards	GM3-B04E	4 modules	
	GM3-B06E	6 modules	
	GM3-B08E	8 modules	
Expansion cables	G3C-E061	Length : 0.6m	
	G3C-E121	Length : 1.2m	
	G3C-E301	Length : 3.0m	
Memory module	G3M-M064	Flash memory, 64k steps	
Power supply modules	GM3-PA1A	110VAC	5VDC : 7A, 24VDC : 1.5A
	GM3-PA2A	220VAC	
	GM1-PA1A	110VAC	5VDC : 13A, 24VDC : None
	GM1-PA2A	220VAC	
	GM3-PD3A	24VDC	5VDC : 4A, 24VDC : bypass

(continued)

Items	Model No.	Description		Remark
A/D conversion modules	G3F-AD4A	Voltage / Current input, 16 channels -5 ~ 5VDC / -10 ~ 10VDC DC -20 ~ 20mA		
	G3F-AD4B	Voltage / Current input, 16 channels 1 ~ 5VDC / 0 ~ 10VDC DC 4 ~ 20mA		
	G3F-AD3A	Voltage / Current input, 8 channels 1 ~ 5VDC / 0 ~ 10VDC DC 4 ~ 20mA		
D/A conversion modules	G3F-DV4A	Voltage output, 16 channels -5 ~ 5VDC / -10 ~ 10VDC		
	G3F-DI4A	Current output, 16 channels DC 4 ~ 20mA		
	G3F-DV3A	Voltage output, 8 channels 0 ~ 10VDC		
	G3F-DI3A	Current output, 8 channels DC 4 ~ 20mA		
Power supply module	G3F-PA1A	110VAC	+15VDC : 0.5A -15VDC : 0.1A	For A/D & D/A modules
	G3F-PA2A	220VAC		
High speed counter module	G3F-HSCA	Counting range (0 ~ 16,777,215 : binary 24 bits) 50kHz, 2 channels		
Positioning module	G3F-POPA	Pulse output, 1 axis control		
	G3F-POAA	Analog output, 2 axes control		
Thermocouple input module	G3F-TC4A	Sensor type : 7 types (K, J, E, T, B, R, S) 16 channels		
RTD module	G3F-RD3A	Sensor type : Pt100, JPt100 8 channels		
PID control module	G3F-PIDA	Max. 32 loops control		
Analog timer module	G3F-AT4A	16 analog timers Setting range : 0.1 ~ 1.0sec / 1 ~ 10sec 10 ~ 60sec / 60 ~ 600sec		Each channel can be set independently
Interrupt module	G3F-INTA	16 channels		

(continued)

Items	Model No.	Description	Remark	
Network modules	G3L-FUEA	Fnet I/F module 1Mbps base band, Twisted pair cable		
	G3L-FUOA	Fnet I/F module 1Mbps base band, Optical fiber cable		
	G0L-FUEA	Fnet I/F module 1Mbps base band, Twisted pair cable	Install to the IBM compatible PC	
	G3L-RBEA	Fnet remote I/F module 1Mbps base band, Twisted pair cable		
	G3L-RBOA	Fnet remote I/F module 1Mbps base band, Optical fiber cable		
	G0L-SMIA	Fnet single I/F module 12 / 24VDC input, 16 points		
	G0L-SMQA	Fnet single I/F module Relay output, 1A/point, 16 points		
	G0L-SMHA	Fnet single I/F module 12 / 24VDC input, 8 points Relay output, 1A/point, 16 points		
	G0L-FREA	Repeater for Fnet		
	Converter	G0L-FOEA	Optical ↔ Electrical converter	
	Active coupler	G0L-FAPA	Power module for active coupler	
		G0L-FABA	Base board for active coupler	
		G0L-FACA	Active coupler	
G0L-FADA		Dummy card for active coupler		
Cnet modules	G3L-CUEA	Cnet I/F module (RS-232C:1ch / RS422:1ch)		
Profibus-DP I/F module	G3L-PUEA	Profibus-DP master module (I/O : 1K)	In 3.0 or higher CPU O/S version and 3.2 or higher KGL-WIN version	
	G3L-PUEB	Profibus-DP master module (I/O : 7K)		
Others	Pseudo input switch	G3S-SW32	Pseudo input switch, 32 points	
	Dust cover	G3F-DMMA	Dust protector for unused slot	

2.3 System configuration types

System configuration is classified into 3 types such as basic, computer link, and network system.

2.3.1 Basic system configuration

The basic system consists of a main base and expansion base(s). The main and expansion base(s) are connected via expansion cable.

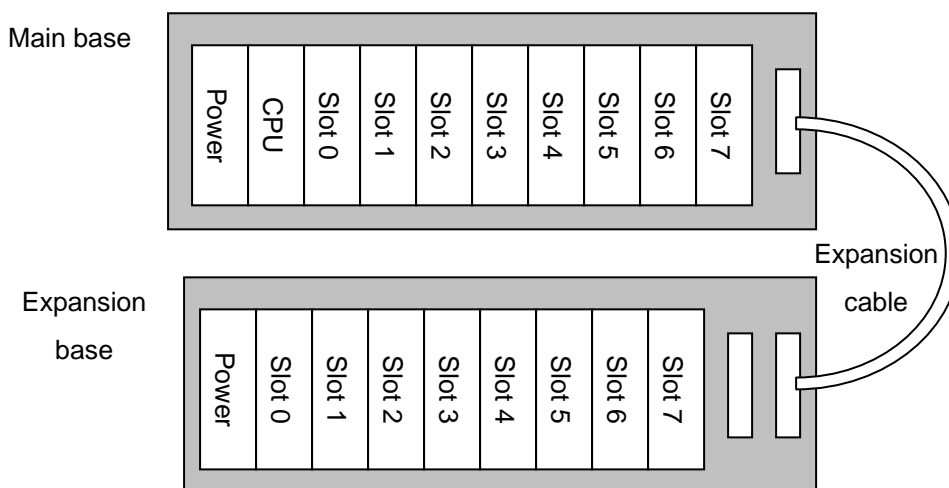

		K200S	K300S	K1000S
Max. expansion level		-	3 levels	
Max. distance between bases		-	3 m	
Max. numbers of I/O module		12 modules	32 modules	
Max. I/O points		384 points	512/1,024 points ¹	1,024 points
Module type	CPU	K3P-07AS	K4P-15AS	K7P-30AS
	Power supply	GM6-PAFA/B/C GM6-PDFA/B	GM4-PA1A/PA2A GM4-PA1B/PA2B GM4-PD3A	GM3-PA1A/PA2A GM3-PA1B/PA2B GM3-PD3A
	Main base	GM6-B04/06/08/12M	GM4-B04/06/08/12M	GM3-B04/06/08M
	Expansion base	-	GM4-B04/06/08E	GM3-B04/06/08E
	Expansion cable	-	G4C-E041/121/301	G3C-E061/121/301
	I/O module Special-function module	G6I-□□□□ G6Q-□□□□ G6F-□□□□	G4I-□□□□ G4Q-□□□□ G4F-□□□□	G3I-□□□□ G3Q-□□□□ G3F-□□□□
I/O number allocation		I/O number (P00, P01, ...) is allocated for each module automatically. A empty slot occupies 16 bits. Special-function modules can be mounted on all bases and slots with no limit on the number of modules.		

¹Only in 3.0 or higher CPU O/S version

2.3.2 Computer link system

When a CPU module is connected with external devices (such as computer or printer, etc.) via RS-232C or RS-422/485 protocol by using computer link module, it is called as computer link system. For details about computer link system, please refer user's manual of MK computer link modules.

Remark

The maximum number of Cnet modules that can be mounted simultaneously is as following;

K200S : 2 modules

K300S : 4 modules

K1000S : 8 modules

Cnet modules can be mounted only main base board. (Not available for expansion base board)

In 3.0 or higher CPU O/S version, Cnet module can be mounted on a main or expansion base board-

2.3.3 Network system

In network system, user can access and control I/O module of remote station through a network I/F and remote I/F module. MASTER-K series uses the Fnet system to consist a network system.

Besides, in 3.0 or higher CPU O/S version and in 3.2 or higher KGL-WIN version, user who want to use other network system can use the Dnet I/F system or Profibus I/F to construct a network system. (Dnet I/F system or Profibus I/F system is available for K300S and Profibus I/F system is available for K1000S)

Please refer the user's manual of Fnet network module for details.

1. Fnet network module can be mounted on main a base board only. It can not be mounted on a expansion base board

The maximum number of Fnet modules that can be mounted simultaneously is as following;

K300S: 2 modules K1000S : 4 modules

2. In 3.0 or higher K300S/1000S CPU O/S version , high-speed link communication module can be mounted on a main or expansion base board and the maximum number that can be mounted simultaneously is 4

3. The remote system has same configuration with a basic system configuration. However, the following modules can not be used on the remote system which a Fnet remote I/F module is mounted.

PID control module	G4F-PIDA	G3F-PIDA
Positioning module	G4F-POPA	G3F-POPA
	G4F-POPB	G3F-POAA
Analog timer module	G4F-AT3A	G3F-AT4A
Fnet I/F module	G4L-FUEA	G3L-FUEA
Cnet I/F module	G4L-CUEA	G3L-CUEA

Example) K300S Network system

Chapter 3 General specifications

3 General specifications.....	3-1
--------------------------------------	------------

3 General specifications

The following table shows the general specifications of MASTER-K series.

No	Item	Specifications	Remark			
1	Operating ambient temperature	0 ~ 55 °C (32 ~ 131 °F)				
2	Storage ambient temperature	-25 ~ 70 °C (-13 ~ 158 °F)				
3	Operating ambient humidity	5 ~ 95%RH, non-condensing				
4	Storage ambient humidity	5 ~ 95%RH, non-condensing				
5	Vibration resistance	Occasional vibration				IEC 1131-2
		Frequency	Acceleration	Amplitude	Sweep count	
		10 ≤ f < 57 Hz	-	0.075 mm	10 times in each direction for X, Y, Z	
		57 ≤ f ≤ 150 Hz	9.8 m/s ² (1G)	-		
		Continuos vibration				
		Frequency	Acceleration	Amplitude		
		10 ≤ f < 57 Hz	-	0.035 mm	10 times in each direction for X, Y, Z	
57 ≤ f ≤ 150 Hz	4.9 m/s ² (0.5G)	-				
6	Shock resistance	Maximum shock acceleration: 147 m/s ² (15G) Duration time :11 ms (3 times in each of X, Y and Z directions) Pulse wave: half sine wave pulse	IEC 1131-2			
7	Noise immunity	Square wave impulse noise	± 1,500 V			LGIS 's specification
		Electrostatic discharge	Voltage :4 kV(contact discharge)			IEC 1131-2 IEC 801-2
		Radiated electro-magnetic field	27 ~ 500 MHz, 10 V/m			IEC 1131-2 IEC 801-2
		Fast transient burst noise	Severity Level	All power modules	Digital I/O (Ue ≥ 24 V)	Digital I/O (Ue < 24 V) Analog I/O Communication I/O
Voltage	2 kV		1 kV	0.25 kV		
8	Atmosphere	Free of corrosive gases				
9	Altitude for use	Up to 2,000m (6,560ft)				
10	Pollution degree	2				
11	Cooling method	Self-cooling				

Remark

1. IEC (International Electrotechnical Commission) : The international civilian organization which produces standards for electrical and electronics industry.
2. Pollution degree : It indicates a standard of operation ambient pollution level. The pollution degree 2 means the condition in which normally, only non-conductive pollution occurs. Occasionally, however, a temporary conductivity caused by condensation shall be expected.

Chapter 4 CPU modules

4 CPU modules	4-1
4.1 Performance specifications	4-1
4.2 Operation processing of CPU	4-2
4.2.1 Operation method.....	4-2
4.2.2 The operation during momentary power failure.....	4-3
4.2.3 Scan time.....	4-4
4.2.4 Watchdog timer.....	4-4
4.2.5 Timers.....	4-5
4.2.6 Counter.....	4-8
4.3 Program structure	4-10
4.3.1 Classification of program.....	4-10
4.3.2 Processing method.....	4-10
4.3.3 Interrupt processing.....	4-11
4.3.4 Error handling.....	4-15
4.4 Operation mode	4-16
4.4.1 RUN mode.....	4-16
4.4.2 Stop mode.....	4-17
4.4.3 PAUSE mode.....	4-18
4.4.4 DEBUG mode.....	4-19
4.4.5 Operation mode change.....	4-20
4.5 Special functions of CPU module	4-22
4.5.1 RTC (Real Time Clock) function.....	4-22
4.5.2 Forced I/O setting.....	4-25
4.5.3 Program edit in RUN mode.....	4-26
4.5.4 Self-diagnosis.....	4-27
4.5.5 Direct I/O refresh.....	4-28
4.5.6 System error history.....	4-28
4.6 Memory configuration	4-29
4.6.1 Memory map of K200S / K300S.....	4-29
4.6.2 The memory map of K1000S.....	4-30
4.7 Assign I/O address	4-31
4.8 Parts names	4-32

4 CPU modules

4.1 Performance specifications

The performance specification of K200S / 300S / 1000S series is shown as following table;

Item	Specifications				Remarks
	K200S	K300S		K1000S	
		2X or lower CPU O/S version	3X or higher CPU O/S version		
Program control method	Cycle execution of stored program, Time-driven interrupt, Process-driven interrupt				
I/O control method	Indirect mode (Refresh method), Direct by program command				
Program language	Mnemonic, Ladder diagram				
Numbers of instructions	Basic : 30, Application : 218				
Processing speed	0.5μsec/step	0.2μsec/step		0.2μsec/step	
Program capacity	7k steps	15k steps		30k steps	
Max. I/O points	384 points	512 points	1,024 points	1,024 points	
Memory device	P	P000 ~ P31F (512 points)		P000 ~ P63F (1,024 points)	I/O relay
	M	M000 ~ M191F (3,072points)			Auxiliary relay
	K	K000 ~ K31F (512 points)			Keep relay
	L	L000 ~ L63F (1,024 points)			Link relay
	F	F000 ~ F63F (1,024 points)			Special relay
	T	100ms : T000 ~ T191 (192 points) 10ms : T192 ~ T255 (64 points)			Timer
	C	C000 ~ C255 (256 points)			Counter
	S	S00.00 ~ S99.99 (100×100 steps)			Step controller
	D	D0000 ~ D4999 (5,000 words)		D0000 ~ D9999 (10,000 words)	Data register
Operation modes	RUN, STOP, PAUSE, DEBUG				
Self-diagnosis functions	Detect errors of scan time, memory, I/O, battery, and power supply				
Data back-up method	Battery-back-up				
Max. expansion level	None	Up to 3 level			
Current consumption	170mA(A type) 210mA(B,C type)	130mA		130mA	
Weight	0.11kg	0.25kg		0.42kg	

4.2 Operation processing of CPU

4.2.1 Operation method

1) The repetitive operation

The repetitive operation method repeats execution of a series of operations. The CPU repeats the operation processing as following;

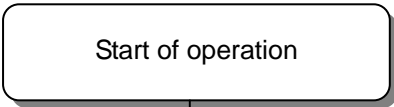
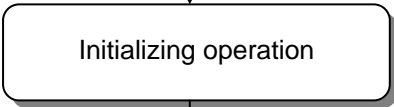
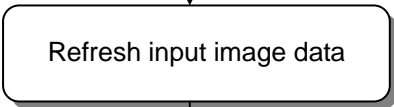
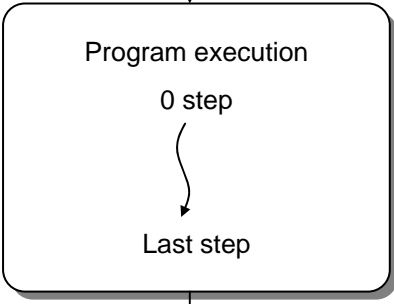
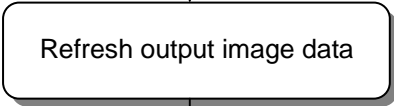
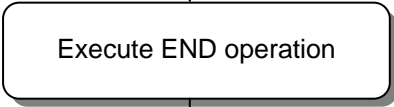
Step	Description
	
	<p>The preparation step to execute scan operation Executed only 1 time when power is turned on or CPU is reset.</p> <p>The following operation is executed;</p> <ul style="list-style-type: none"> - I/O module reset - Self-diagnosis operation - Clear non-retentive data - Read I/O information and assign address
	<p>Before start of scan operation, read the status of input module and store it to the input image data area.</p>
	<p>Execute the user program from step 0 to the last step</p>
	<p>After the last step is executed, output the operation result of output image data area to the output module</p>
	<p>Before restart scan operation, the following operation is executed;</p> <ul style="list-style-type: none"> - Self-diagnosis operation - Update the current value of timer and counter - Execute data transmission with network module - Check the operation mode is changed or not

2) Interrupt operation

When the CPU detects an interrupt signal, it stops the current operation and execute the corresponding interrupt routine. After the interrupt routine is completed, the CPU resumes to execute the previous operation from the stopped point.

The MASTER-K 200S/300S/1000S has two interrupt types that are time-driven interrupt (TDI) and process-driven interrupt (PDI). Please refer the chapter 4.3.3 for details.

4.2.2 The operation during momentary power failure

The MASTER-K 200S/300S/1000S series can detect a momentary power failure, and the CPU module decides to continue operation or not according to the period of momentary power failure.

1) Less than 20msec

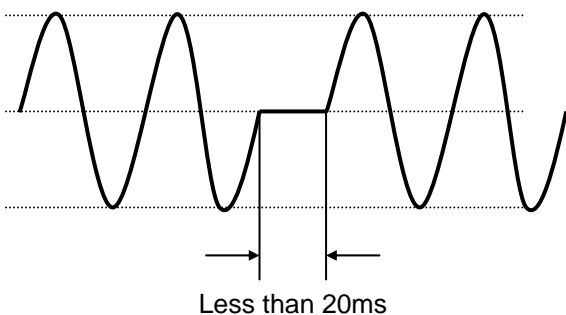

- ① The CPU stop to execute sequence program retaining the state of output.
- ② The time measurement for internal timer and time-driven interrupt keeps normal operation status while the sequence program is stopped.
- ③ When the AC power is recovered, the CPU restarts to execute sequence program.
- ④ The external output of power supply module is kept as the rated voltage and current.

2) Over 20msec

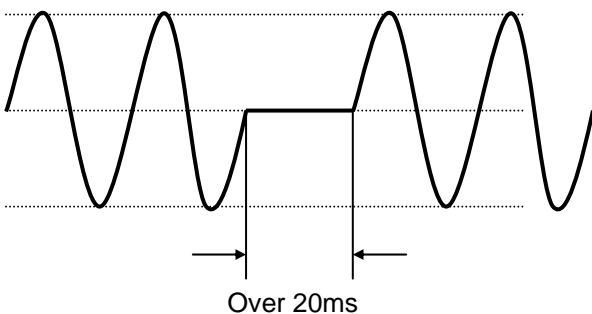

The CPU will initialized and restart operation as the power re-applied.

Remark
 Momentary power failure:
 The power failure of PLC system means the state that AC input voltage is dropped below the minimum value of rated input voltage range. When the period of power failure is short (usually, the 1/2 cycle), it is called as momentary power failure.

4.2.3 Scan time

The series of steps from step 0 to the next step 0 or from an END instruction to the next END instruction is called a scan. The scan time is total time spent to execute a scan.

1) The calculation of scan time

The scan time is calculated as a total of the processing time of sequence program (step 0 to the END), interrupt routine, and internal processing of CPU.

**Scan time = Sequence program processing time + Interrupt routine processing time
+ Internal processing time**

① Sequence program processing time :

The total processing time to execute step 0 to END instruction

② Interrupt processing time :

The total processing time to execute interrupt routine during a scan

③ Internal processing time :

The total processing time to execute self-diagnosis, I/O refresh, timer/counter update, and communication operation

2) The scan time varies with executing interrupt routine and communication operation or not.

3) The scan time of CPU module is stored in the following special relays (F area).

- F50 word : The maximum scan time (unit : ms)
- F51 word : The minimum scan time (unit : ms)
- F52 word : The current scan time (unit : ms)

4.2.4 Watchdog timer

- 1) The watchdog timer is an internal timer of the CPU to detect the error of hardware and sequence program. The default value of watchdog timer is 200msec, and it can be changed in parameter setting. (setting range : 10 ~ 6000msec, unit : 10msec)
- 2) When a scan is not completed before, the watchdog timer error occurs and the operation of CPU is stopped. At this time, all outputs of I/O module are turned off.
- 3) The watchdog timer is reset before step 0 is executed (after the END processing is finished) or the WDT instruction is executed. When write a sequence program contains FOR ~ NEXT loop or a lot of subroutines, increase watchdog timer setting value or put WDT instruction to avoid watchdog timer error. The setting range of watchdog timer is 10 ~ 6000msec
- 4) When a watchdog timer error occurs, it can be cleared by power cycle, manual reset switch (K1000S), or mode change.

4.2.5 Timers

The MASTER-K 200S/300S/1000S series uses upcount timers. There are 5 timer instructions such as on-delay (TON), off-delay (TOFF), integral (TMR), monostable (TMON), and re-triggerable (TRTG) timer.

The measuring time range of 100msec timer is 0.1 ~ 6553.5 sec, and that of 10msec timer is 0.01 ~ 655.35 sec. Please refer the 'MASTER-K programming manual' for details.

1) On delay timer

The current value of timer starts to increase from 0 when the input condition of TON instruction turns on. When the current value reaches the preset value, the timer output relay turns on.

When the timer input condition is turned off, the current value becomes 0 and the timer output relay is turned off.

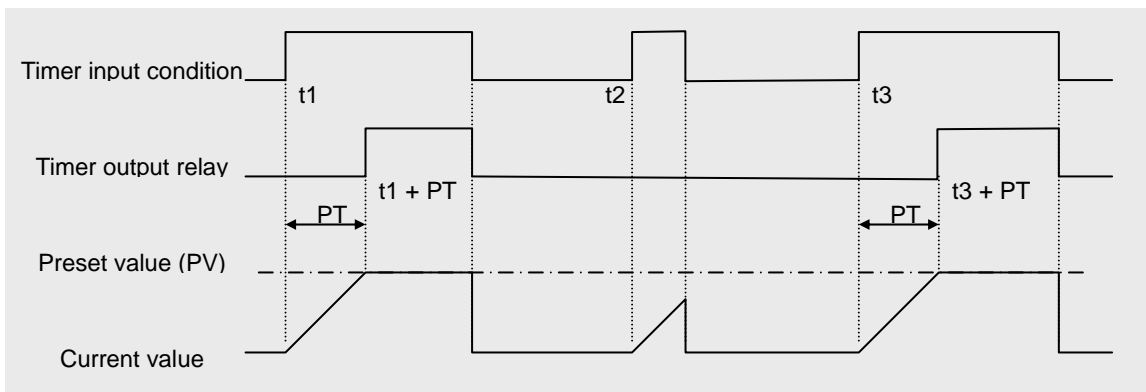

2) Off delay timer

The current value of timer set as preset value and the timer output relay is turned on when the input condition of TOFF instruction turns on. When the input condition is turned off, the current value starts to decrease. The timer output relay is turned off when the current value reaches 0.

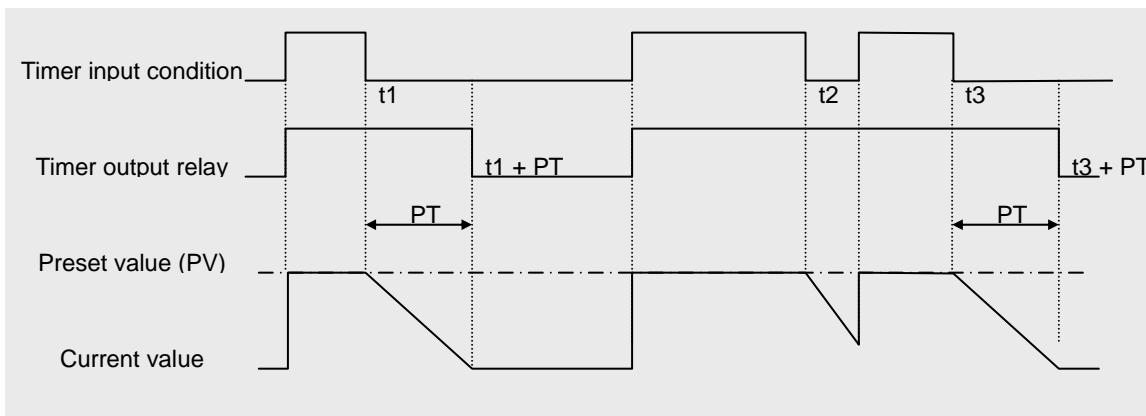

3) Integral timer

In general, its operation is same as on-delay timer. Only the difference is the current value will not be clear when the input condition of TMR instruction is turned off. It keeps the elapsed value and restart to increase when the input condition is turned on again.

When the current value reaches preset value, the timer output relay is turned on.

The current value can be cleared by the RST instruction only.

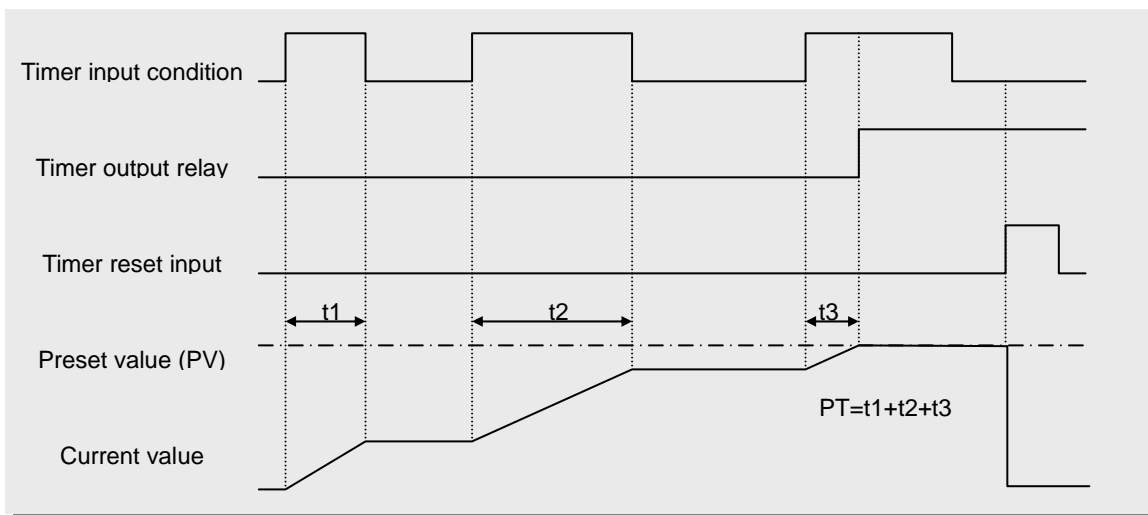

4) Monostable timer

In general, its operation is same as off-delay timer. However, the change of input condition is ignored while the timer is operating (decreasing).

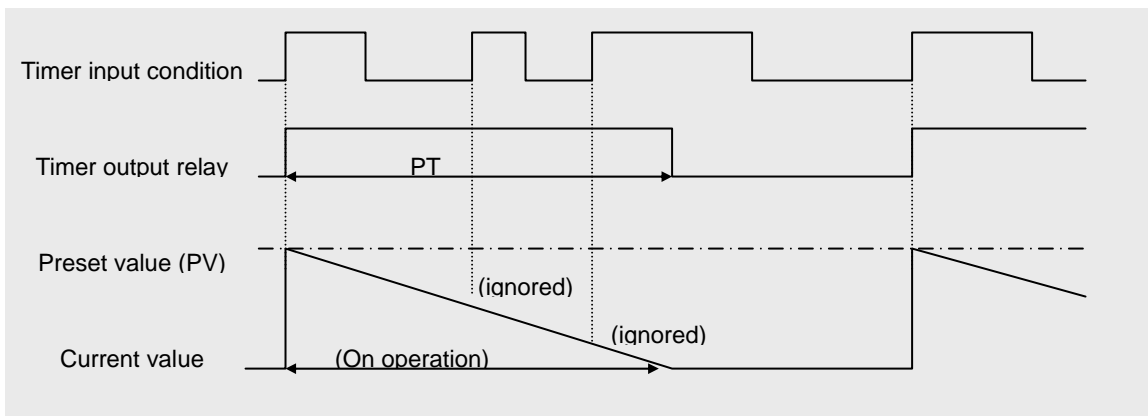

5) Retriggerable timer

The operation of retriggerable timer is same as that of monostable timer. Only difference is that the retriggerable timer is not ignore the input condition of TRTG instruction while the timer is operating (decreasing). The current value of retriggerable timer will be set as preset value whenever the input condition of TRTG instruction is turned on.

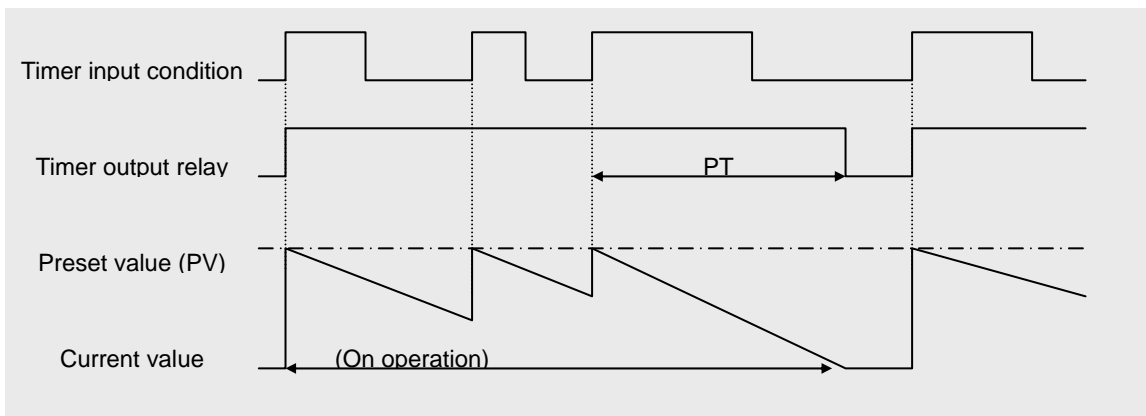
**Remark****The accuracy of timer:**

The Maximum timing error of timers of MASTER-K series is + 2 scan time ~ - 1 scan time. Refer the programming manual for details.

4.2.6 Counter

The counter counts the rising edges of pulses driving its input signal and counts once only when the input signal is switched from off to on. MASTER-K series have 4 counter instructions such as CTU, CTD, CTUD, and CTR. The maximum counter setting value is hFFFF (= 65535). The followings shows brief information for counter operation.

1) Up counter (CTU)

The counter output relay is turned on when the current value reaches the preset value. After the counter relay output is turned on, the current value will increase until it reaches the maximum counting value (hFFFF = 65535).

When the reset input is turned on, the counter output relay and current value is cleared as 0.

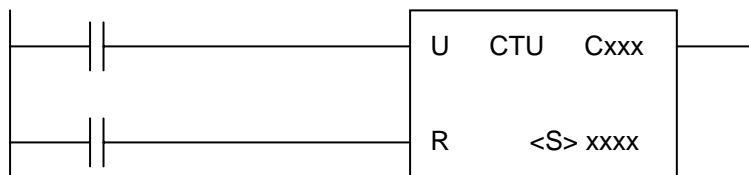

2) Down counter (CTD)

When the CPU is switched to the RUN mode, the current value is set as preset value.¹ The current value is decreased by 1 with the rising edge of counter input signal. The counter output relay is turned on when the current value reaches 0.

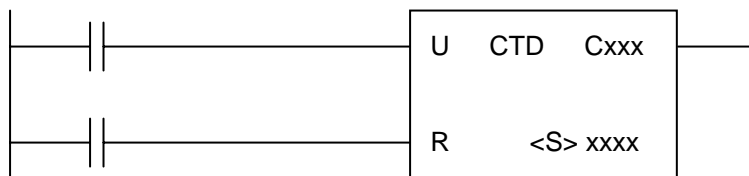

¹ If the retentive counter area is used for down counter, the reset input has to be turned on to initialize counter.

3) Up-down counter

The current value is increased with the rising edge of up-count input signal, and decreased with the rising edge of down-count input signal. The counter output relay is turned on when the current value is equal or greater than the preset value.

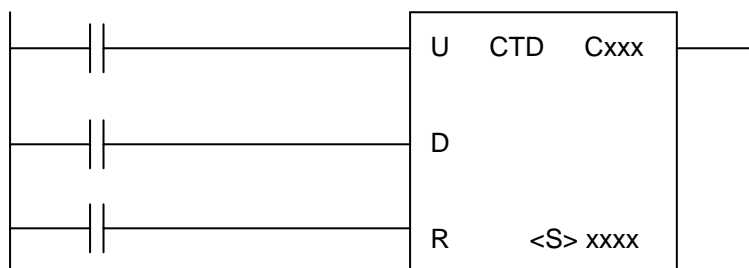

4) Ring counter

The current value is increased with the rising edge of the counter input signal, and the counter output relay is turned on when the current value reaches the preset value. Then the current value and counter output relay is cleared as 0 when the next counter input signal is applied.

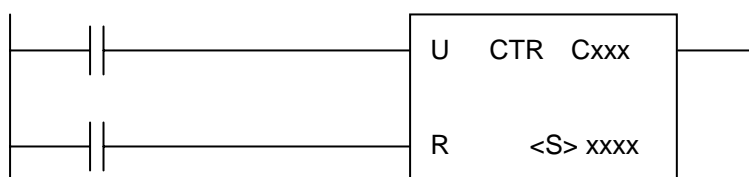

Remark

1. Maximum counting speed

The maximum counting speed of counter is determined by the length of scan time. Counting is possible only when the on/off switching time of the counter input signal is longer than scan time.

$$\text{Maximum counting speed } (C_{\max}) = \frac{n}{100} \times \frac{1}{t_s} \text{ (times/sec)} \quad n : \text{duty (\%), } t_s : \text{scan time}$$

2. Duty

Duty is the ratio of the input signal's on time to off time as a percentage.

If $T1 \leq T2$, $n = \frac{T1}{T1 + T2} \times 100 \text{ (\%)}$

If $T1 > T2$, $n = \frac{T2}{T1 + T2} \times 100 \text{ (\%)}$

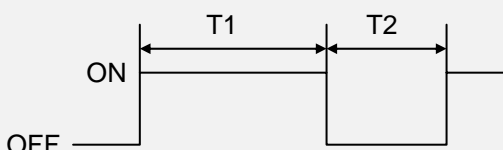

4.3 Program structure

4.3.1 Classification of program

All functional elements need to execute a certain control process are called as a 'program'. In MASTER-K series, a program is stored in the RAM mounted on a CPU module or flash memory of a external memory module. The following table shows the classification of the program.

Program type	Description
Scan program	The scan program is executed regularly in every scan. If the scan program is not stored, the CPU cannot execute not only the scan program but also other programs.
Time-driven interrupt program (TDI)	The TDI programs are executed with a constant time interval specified with parameter setting.
Process driven interrupt program (PDI)	The PDI programs are executed only external interrupt input is applied and the corresponding interrupt routine is enabled by EI instruction.
Subroutine program	The subroutine programs are executed when they are called by the scan program with a CALL instruction.

4.3.2 Processing method

The following diagram shows that how the CPU module process programs when the CPU module is powered on or switched to RUN mode.

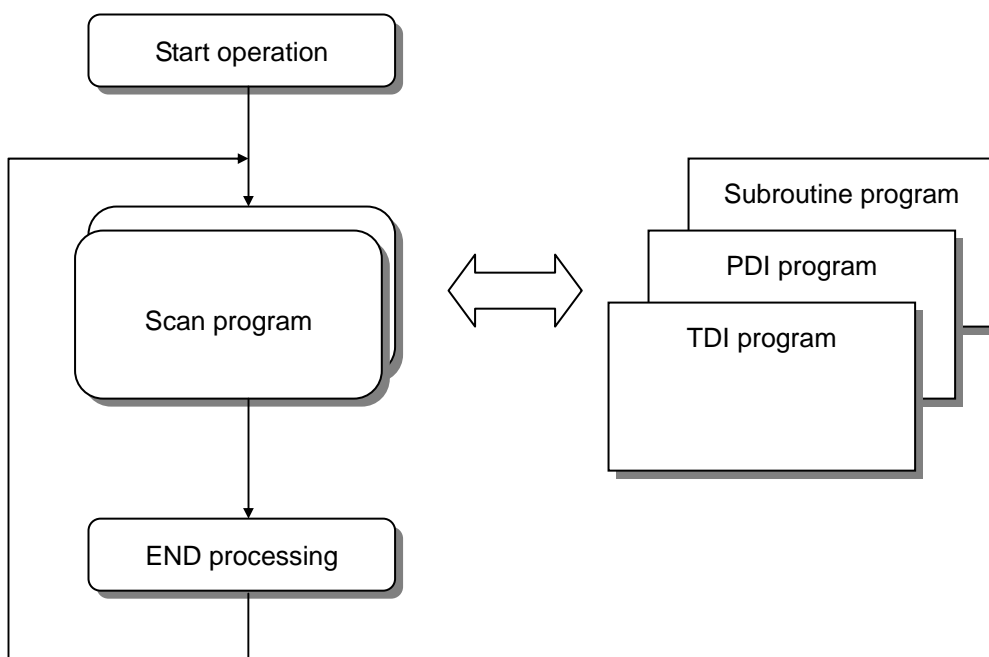

1) Parameter setting

K200S			K300S			K1000S		
Priority	Type	Period	Priority	Type	Period	Priority	Type	Period
0	TDI0	10ms	0	TDI0	10ms	0	TDI0	10ms
1	TDI2	25ms	1	TDI2	25ms	1	TDI2	25ms
2	TDI5	100ms	2	TDI5	100ms	2	TDI5	100ms
:	:		:			:		
:	:		:			:		
7	INT7		:			:		
			13	INT7		:		
						29	INT15	

Remark
 Period is the interval of time driven interrupt occurring. It is variable from 10 ms to 60,000 ms (60ms) by 10 ms.

Remark
 Interrupt processing during momentary power failure:
 If process-driven interrupts occur during a momentary power failure (power failure less than 20 ms), they are executed after the power is recovered. If a time-driven interrupt occurs two or more times during momentary power failure, it executes only once after power is recovered.
 During momentary power failure, the CPU keep measuring time and the period of momentary power failure is included in the period of TDI.

2) TDI (Time driven interrupt)

TDI occurs periodically with the constant interval assigned in parameter setting. The interrupt routine of TDI starts with the TDINT instruction and ends with the IRET instruction.

When multiple interrupt factors occur simultaneously, interrupt routines are executed according to the priority given to the each interrupt. If an interrupt factor has higher priority occurs while other interrupt of lower priority is executing, the interrupt routine of lower priority will be stopped and the interrupt of higher priority will be executed first. Otherwise, two interrupts are executed consecutently.

The maximum numbers of TDI for K200S / 300S / 1000S are shown as following table.

PLC type	Available TDI
K200S	TDINT 0 ~ 7
K300S	TDINT 0 ~ 13
K1000S	TDINT 0 ~ 29

The following figure shows an example of TDI execution.

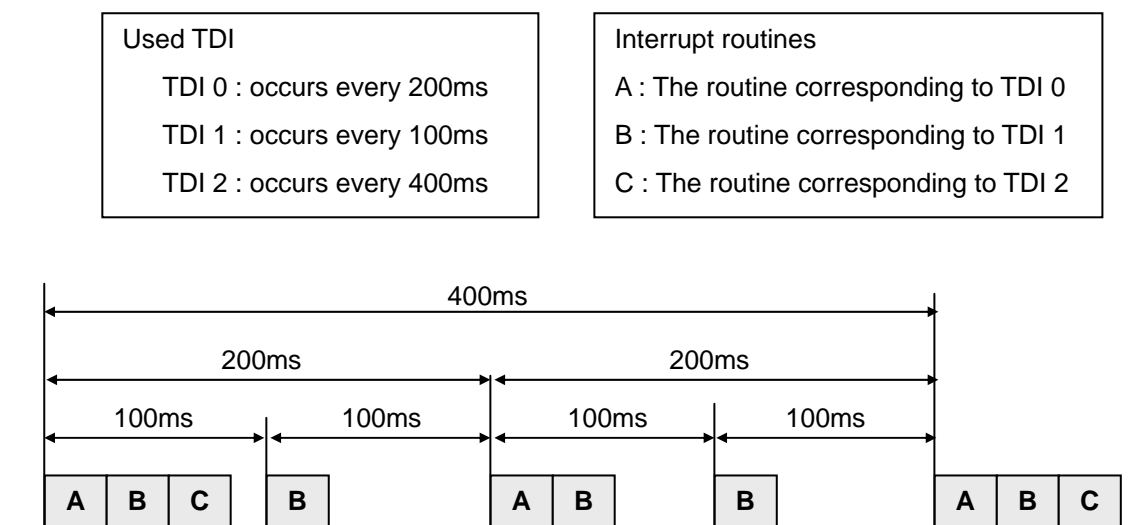

3) PDI (Process driven interrupt)

PDI occurs when the input status of interrupt module is changed from OFF to ON or from ON to OFF. (Select by DIP switch setting) Since K200S does not have interrupt module, PDI will occur when the input assigned as interrupt input by parameter setting is changed from OFF to ON.

The execution order of multiple interrupts is similar as TDI. The following figure shows an example of execution order of multiple PDI.

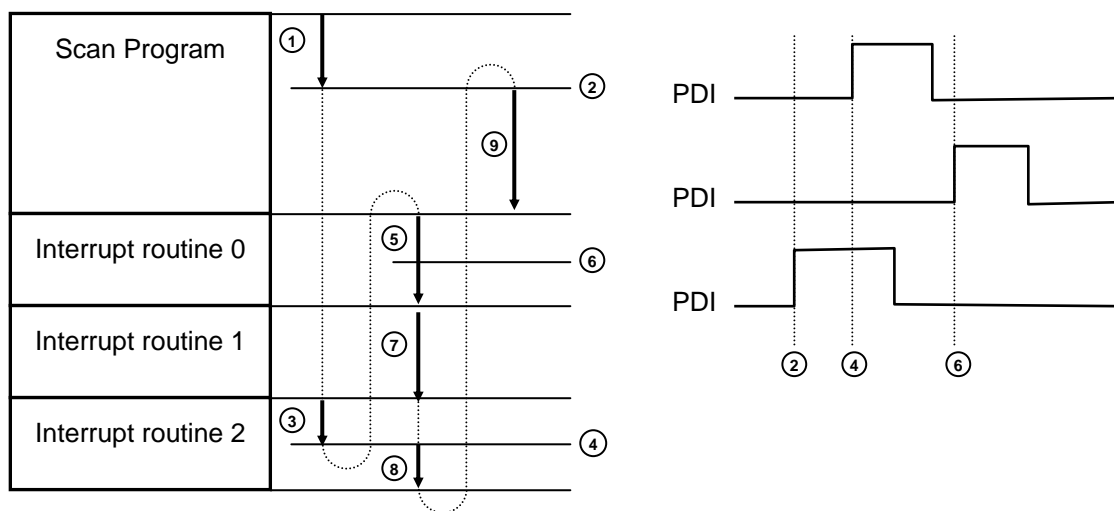

- ① Program starts
- ② Interrupt 2 occurs
- ③ Stop main program and run PDI routine 2
- ④ Interrupt 0 occurs (higher priority)
- ⑤ Stop routine 2 and execute routine 0
- ⑥ Interrupt 1 occurs (lower priority)
- ⑦ Finish routine 0 and execute routine 1
- ⑧ Finish routine 1 and resume routine 2
- ⑨ Finish routine 2 and back to main program

4.3.4 Error handling

1) Error classification

Error occurs due to various causes such as PLC system errors, system configuration fault or abnormal operation result. Errors are classified into fatal error that stops system operation for safety, and ordinary error that continue system operation with informing the user of error warning.

The causes of system error are as following;

- The hardware error
- System configuration error
- Operation error during execution of user program
- External device malfunction

2) Operation mode at error occurrence

In case of error occurrence, the CPU stores corresponding error code at error flags, and stop / continue operation according to the error type.

① The hardware error

The system is changed to STOP mode when a fatal error such as CPU defection occurs. When an ordinary error such as battery error occurs, the system keep its operation status.

② System configuration error

This error occurs when actual hardware configuration conflicts with the configuration assigned in parameter setting. The system is changed to the STOP mode.

③ Operation error during execution of user program

When a arithmetic operation error occurs, the system output error code at the corresponding error flag and continue operating. If a scan time exceeds the watchdog timer setting value or mounted I/O module is not normally controlled, the system is switched to the STOP mode.

④ External device malfunction

The CPU can detect an external device malfunction with user program. If a fatal error detected, the system is stopped. Otherwise, it continues operating.

Remark

1. When an error occurs, the error code is stored at special relay (F006 word).
2. Refer the appendix 1 'Flag list' for details of error flags.

4.4 Operation mode

The operation mode of CPU module can be classified into 4 modes such as RUN, STOP, PAUSE, and DEBUG modes.

4.4.1 RUN mode

In the RUN mode, the CPU process user programs normally.

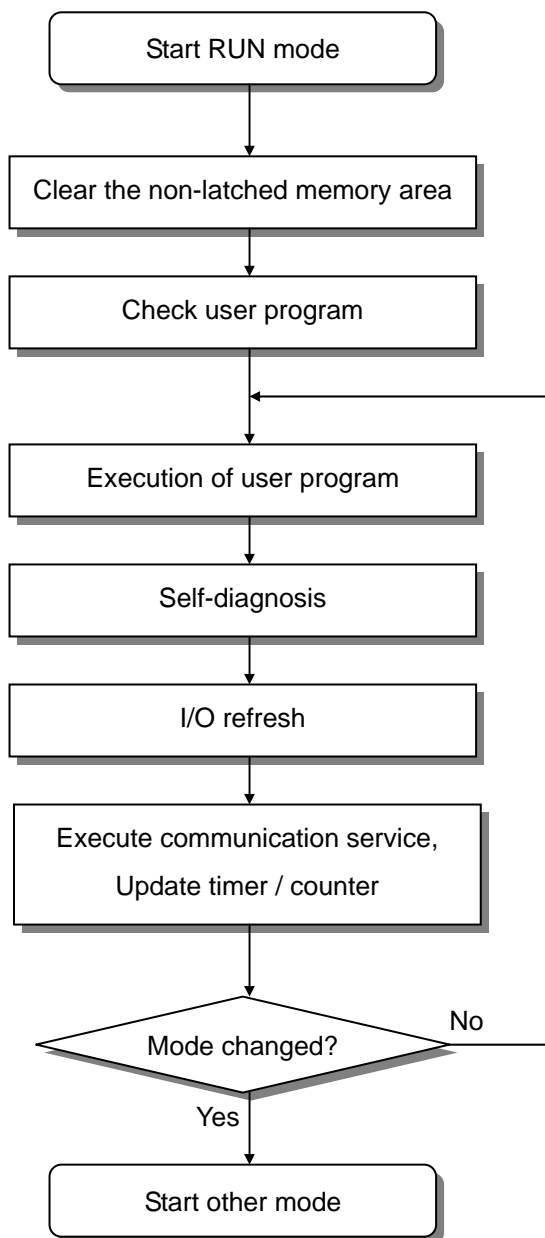

4.4.2 Stop mode

In the STOP mode, the CPU does not execute program. Program change through KGL-WIN is possible in the remote STOP mode only.

External wiring check is also possible with the forced I/O on/off function.

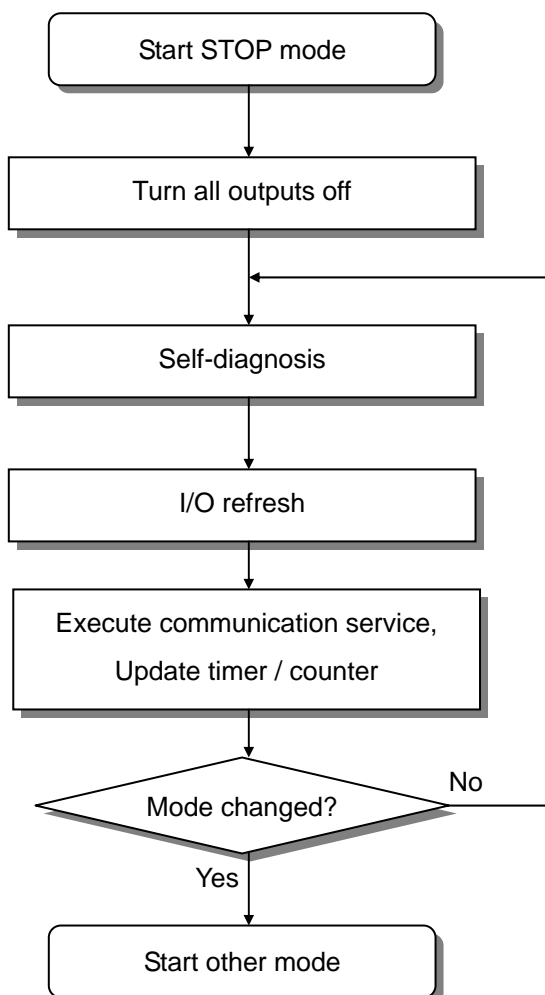

4.4.3 PAUSE mode

In PAUSE mode, the CPU stops executing user program, but keeps the status of output and internal memory.

When the mode is changed to RUN mode, the CPU restart executing user program from the step at which the user program is stopped.

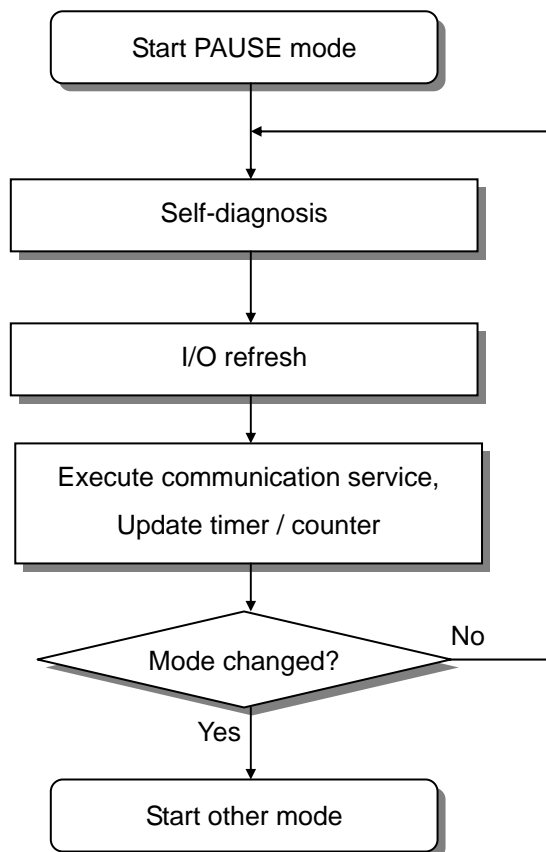

4.4.4 DEBUG mode

For debugging of user program, the MASTER-K 200S/300S/1000S provides the DEBUG mode. In the DEBUG mode, the CPU executes user program according to the execution condition as following;

- ① Step over : Executes just an operation unit (one instruction)
- ② Break point : Executes user program until the specified step (break point)
- ③ Device state : Execute user program until a device (bit or word) assigned to be monitored is changed to the specified status (read, write, value)
- ④ Scan loop : Execute user program for specified number of scans

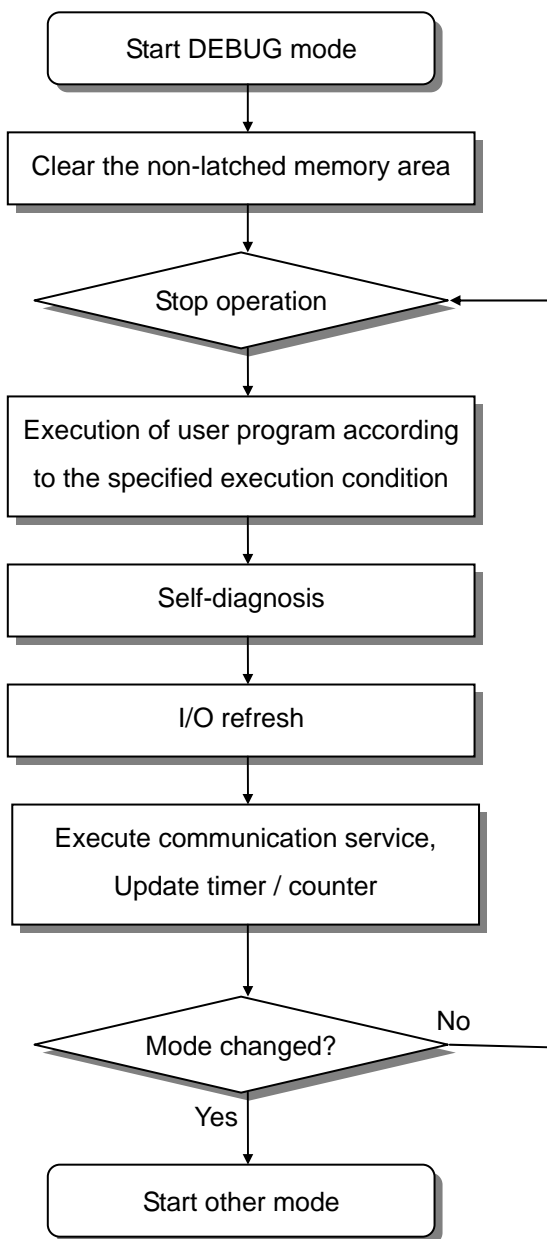

Remark

It is forbidden to enter DEBUG mode from RUN or PAUSE mode.

Remark

In DEBUG mode, each interrupt program can be enabled / disabled separately.

4.4.5 Operation mode change

- 1) The operation mode of CPU can be change by following methods;
 - ① The mode key switch on the CPU module
 - ② KGL-WIN connected to the CPU through loader port
 - ③ KGL-WIN connected to the remote CPU through a fieldbus network
 - ④ User command through a FAM or computer link module
 - ⑤ The 'STOP' instruction of user program
- 2) Mode change by mode key switch

The following table shows how the operation mode is changed by mode key switch

Mode key switch	Operation mode
RUN	Local RUN
STOP	Local STOP
PAU / REM	Local PAUSE / Remote (RUN / STOP / PAUSE)
RUN → PAU / REM	Local RUN → Local PAUSE
PAU / REM → STOP	Local PAUSE / Remote → Local STOP
STOP → PAU / REM	Local STOP → Remote STOP
PAU / REM → RUN	Local PAUSE / Remote → Local RUN

Remark

The CPU operates continuously when the operation mode is changed as remote RUN → local RUN

3) Remote mode change

To change operation mode with KGL-WIN or KLD-150S, the mode key switch should be in the remote STOP mode. (Mode key setting : STOP → PAU / REM)

Mode key switch	Mode change	KGL-WIN	FAM / Cnet
PAU / REM	Remote STOP → Remote RUN	O	O
	Remote STOP → Remote PAUSE	X	X
	Remote STOP → DEBUG	O	O
	Remote RUN → Remote PAUSE	O	O
	Remote RUN → Remote STOP	O	O
	Remote RUN → DEBUG	X	X
	Remote PAUSE → Remote RUN	O	O
	Remote PAUSE → Remote STOP	O	O
	Remote PAUSE → DEBUG	X	X
	DEBUG → Remote RUN	X	X
	DEBUG → Remote PAUSE	X	X
	DEBUG → Remote STOP	O	O

4.5 Special functions of CPU module

4.5.1 RTC (Real Time Clock) function

MASTER-K 200S/300S/1000S series includes RTC function. (K200S-A does not have RTC function) Clock operation by the RTC function is continued with a battery or super capacitor when the CPU is powered off.

1) Clock data

Clock data is the data comprised of year, month, day, hour, minute, second, and date.

Data name	Description	
Year	4 digits of the Christian Era	
Month	1 to 12	
Day	1 to 31 (A leap year is distinguished automatically)	
Hour	0 to 23 (24 hours)	
Minute	0 to 59	
Second	0 to 59	
Date	0	Sunday
	1	Monday
	2	Tuesday
	3	Wednesday
	4	Thursday
	5	Friday
	6	Saturday

2) Precision

Max. 1.728 second per day (general temperature)

Remark

- The RTC data does not have factory default setting. Please write a correct RTC data before using RTC function first time.
- If unreasonable RTC data is written to the CPU, the RTC function may operate abnormally.

Example : 13 (month) 32 (day)

3) Read / write RTC data

① Read RTC data

The current RTC data

Memory Area (Word)	Description		Data (BCD format)
	Upper byte	Lower byte	
F053	Lower 2 digits of year	Month	h9812
F054	Day	Hour	h2219
F055	Minute	Second	h3746
F056	Higher 2 digits of year	Date	h1902

Example : 1998. 12. 22. 19:37:46, Tuesday

② Write RTC data

There is two ways to write new RTC data to the CPU.

The first one is using a handy loader (KLD-150S) or graphic loader (KGL-WIN). For detailed information, refer the user's manual of KLD-150S or KGL-WIN.

The second one is write sequence program. By switching a special bit on, user can replace the current RTC data with the preset data stored in a specified memory area. The followings are the memory address of preset data and an example program.

The preset RTC data

Memory Area (Word)		Description		Data (BCD format)
K200S / K300S	K1000S	Upper byte	Lower byte	
D4990	D9990	Lower 2 digits of year	Month	h9901
D4991	D9991	Day	Hour	h1711
D4992	D9992	Minute	Second	h5324
D4993	D9993	Higher 2 digits of year	Date	h1900

Example : 1999. 1. 17. 11:53:24, Sunday

M1904 : RTC data change bit

When the M1904 bit is switched on, the new data in D4990 ~ D4993 (K1000S : D9990 ~ D9993) will be moved to F53 ~ F56. After data is moved, M1904 has to be switched off immediately because current data will be updated every scan while M1904 is on.

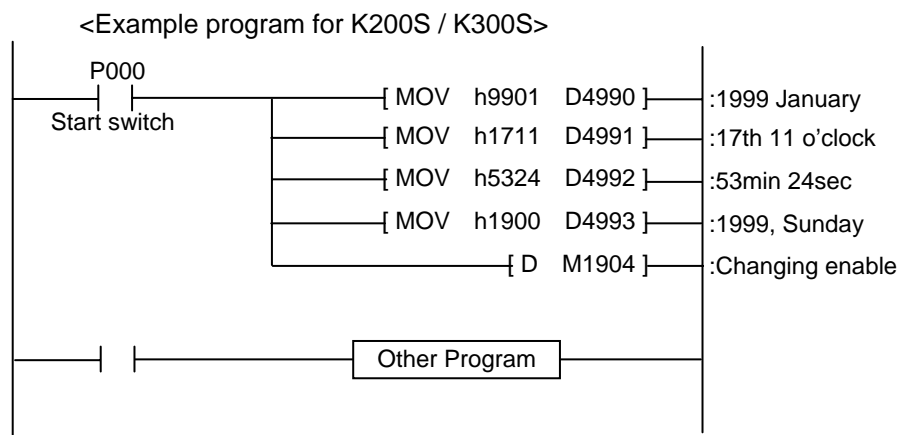

4.5.2 Forced I/O setting

It is possible to output a designated data regardless of the result of operation. This function is useful to check operation of the output modules and wiring between the output modules and external devices.

	K200S	K300S	K1000S
Forced I/O request bit	M1910		
The forced I/O address	D4700 ~		D9700 ~
The forced I/O data	D4800 ~		D9800 ~

Example 1) Output h8721 to the P10 word by force (K200S / K300S)

- a) Write the forced I/O data (h8721) to the corresponding data word. P10 is matched to the D4810 word.

<D4810 word>

F	E	D	C	B	A	9	8	7	6	5	4	3	2	1	0
1	0	0	0	0	1	1	1	0	0	1	0	0	0	0	1

- b) Write the forced I/O address (All bit = hFFFF) to the corresponding address word. Write hFFFF to the D4710.

<D4710 word> (0 = disable forced I/O, 1 = enable forced I/O)

F	E	D	C	B	A	9	8	7	6	5	4	3	2	1	0
1	1	1	1	1	1	1	1	1	1	1	1	1	1	1	1

- c) Switch on the forced I/O request bit (M1910).

d) Output of P10 word

(P : The previous result of operation)

F	E	D	C	B	A	9	8	7	6	5	4	3	2	1	0
P	P	P	P	P	P	P	P	P	P	P	P	P	P	P	P



F	E	D	C	B	A	9	8	7	6	5	4	3	2	1	0
1	0	0	0	0	1	1	1	0	0	1	0	0	0	0	1

Example 2) Switch On/Off the last bit of P07 word (K1000S)

- a) Write the forced I/O data (h0001) to the corresponding data word. P10 is matched to the D9807 word.

<D9807 word>

F	E	D	C	B	A	9	8	7	6	5	4	3	2	1	0
0	0	0	0	0	0	0	0	0	0	0	0	0	0	0	1

- b) Write the forced I/O address (last bit = h0001) to the corresponding address word. Write h0001 to the D9707.

<D9707 word> (0 = disable forced I/O, 1 = enable forced I/O)

F	E	D	C	B	A	9	8	7	6	5	4	3	2	1	0
0	0	0	0	0	0	0	0	0	0	0	0	0	0	0	1

- c) Switch on the forced I/O request bit (M1910).

- d) Output of P07 word

(P : The previous result of operation)

F	E	D	C	B	A	9	8	7	6	5	4	3	2	1	0
P	P	P	P	P	P	P	P	P	P	P	P	P	P	P	P

⇓

F	E	D	C	B	A	9	8	7	6	5	4	3	2	1	0
P	P	P	P	P	P	P	P	P	P	P	P	P	P	P	1

4.5.3 Program edit in RUN mode

User can insert, delete, or change instructions of program while the CPU is running. This function is useful to debugging or test-operation. Please refer the user's manual of KLD-150S or KGL-WIN for detail information.

Remark

The program edit in RUN mode can not be performed for the following instructions – JMP, JME, CALL, SBRT, FOR, and NEXT instructions. Moreover, the program that has very long scan time (2 seconds or more) can not be edited while the CPU is in the RUN mode.

4.5.4 Self-diagnosis

1) WDT (Watch dog timer) function

The watch dog timer is an internal timer of a PLC to detect the error of hardware and a sequence program. The default value is set as 200msec, and it is changeable with parameter setting. Refer the MASTER-K programming manual for details on the parameter setting.

The CPU resets the watch dog timer before step 0 is executed (after the END processing is finished). When the END instruction has not been executed within the set value due to an error occurred in the PLC or the long scan time of a sequence program, the watch dog timer will times out. When a watch dog timer error is occurred, all outputs of the PLC are turned OFF, and the ERR LED of the CPU will flashes. (RUN LED will be turned OFF) Therefore, when use FOR ~ NEXT or CALL instruction, insert WDT instruction to reset the watch dog timer.

2) I/O module check function

If one or more I/O modules are mounted/dismounted while the PLC is powered, the corresponding bit (F0040 ~ F0050 : 32 bits) will be switched on. If a module is mounted improperly, the relevant bit will be switched on also.

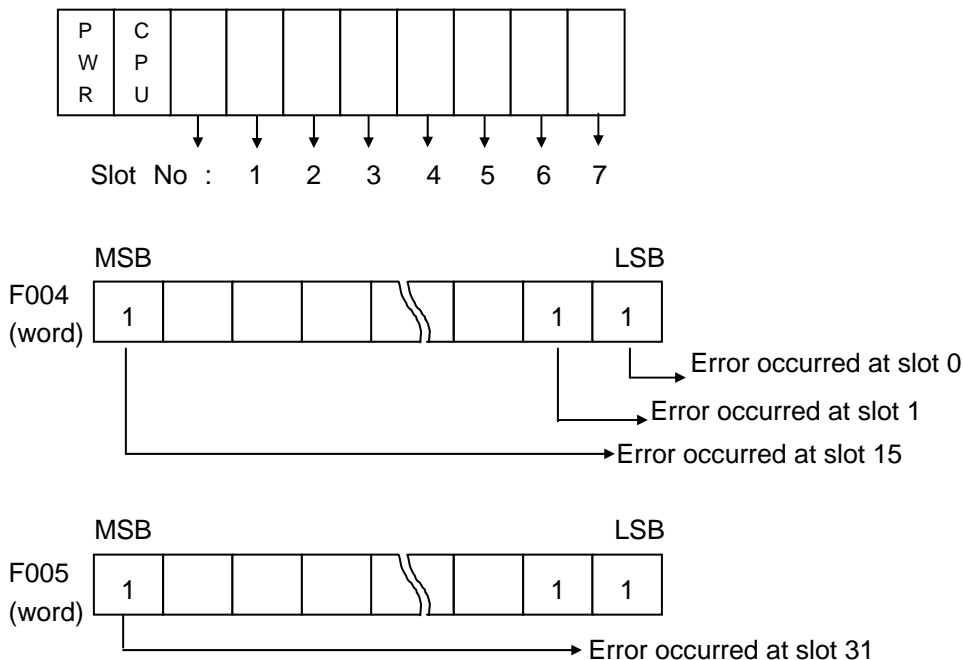

3) Battery check function

When the voltage of the battery for back-up the memory IC of CPU are lower than the minimum back-up voltage, the BAT LED of CPU module will be turned on.

4.5.5 Direct I/O refresh

To read or write the operation result immediately, MASTER-K 200S/300S/1000S provides 'IORF' instruction. When the IORF instruction is executed, the CPU refreshes I/O image data area immediately. Please refer the MASTER-K instruction manual for details.

4.5.6 System error history

When the system is stopped by error occurrence, the CPU stores the error occurrence time and error code to the special data register area. The most recent 16 error occurring times and error codes are stored in the special data register.

1) Special data register

	CPU type			Description
	K200S	K300S	K1000S	
Device	D4901 ~ D4904		D9901 ~ D9904	The latest error information
	D4905 ~ D4908		D9905 ~ D9908	The 2 nd latest error information
	:		:	:
	D4961 ~ D4964		D9961 ~ D9964	The 16 th latest error information

2) Description of each word

Device			Contents	Description
K200S	K300S	K1000S		
D4901		D9901	h9905	Year : 99, Month : 5
D4902		D9902	h2812	Date : 28, Hour : 12
D4903		D9903	h3030	Minute : 30, Second : 30
D4904		D9904	h0001	Error code (h0001)

3) Clear error data

Use a 'data clear' function of KGL-WIN or KLD-150S

Remark

The system error history function is not available with K3P-07AS because it does not have RTC function.

4.6 Memory configuration

4.6.1 Memory map of K200S / K300S

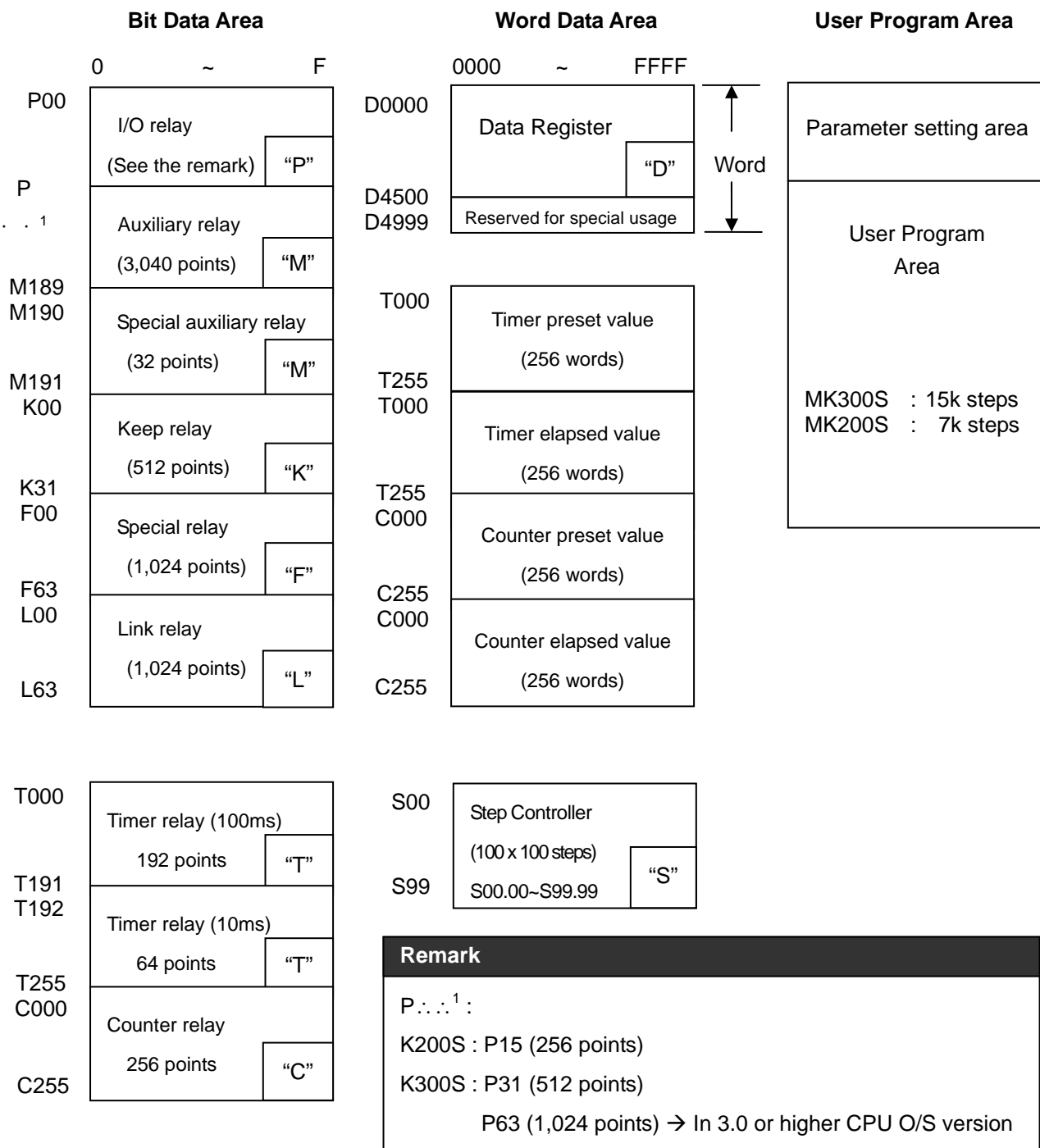

4.6.2 The memory map of K1000S

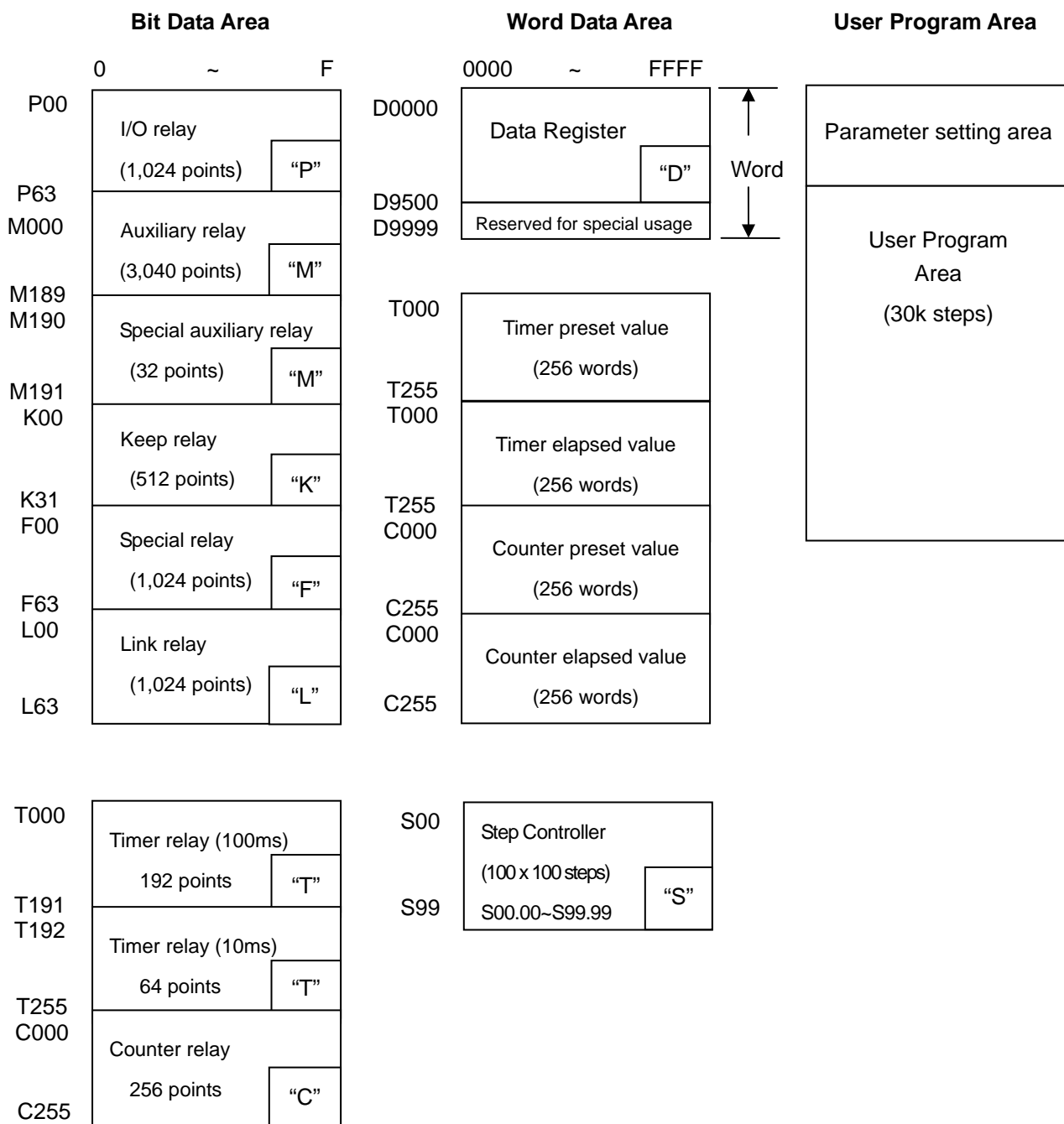

4.7 Assign I/O address

To read / write data I/O and special function modules, the CPU assigns I/O address (P area) to each modules according to the module type. I/O address starts from P00 (word), and it is assigned from left to right. The following figure shows an example of I/O address allocation.

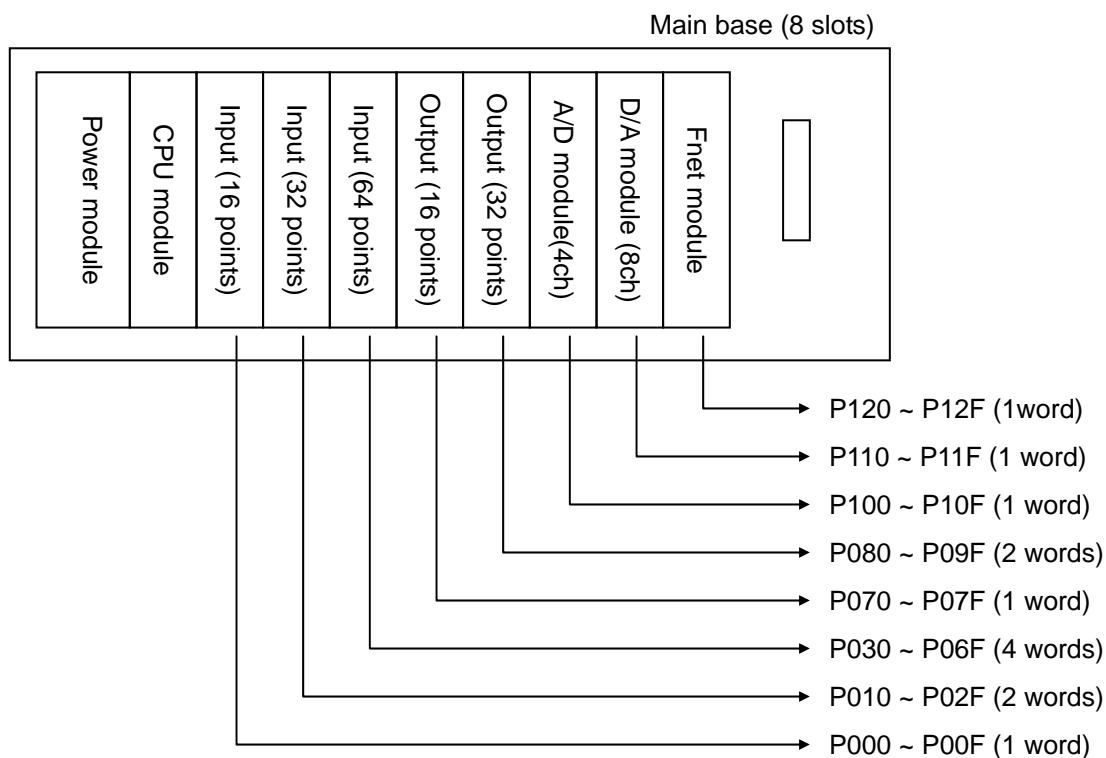

Remark

1. Special function modules occupy various I/O addresses according to the type of module. Please see the user's manual of each special function module for details
2. Special function modules can be mounted on any slots of main / expansion base. There is also no limit on the number of special function modules mountable on a base.
3. In 2.0 or lower K300S/1000S CPU OS version , network module can be mounted on the main base only.

4.8 Parts names

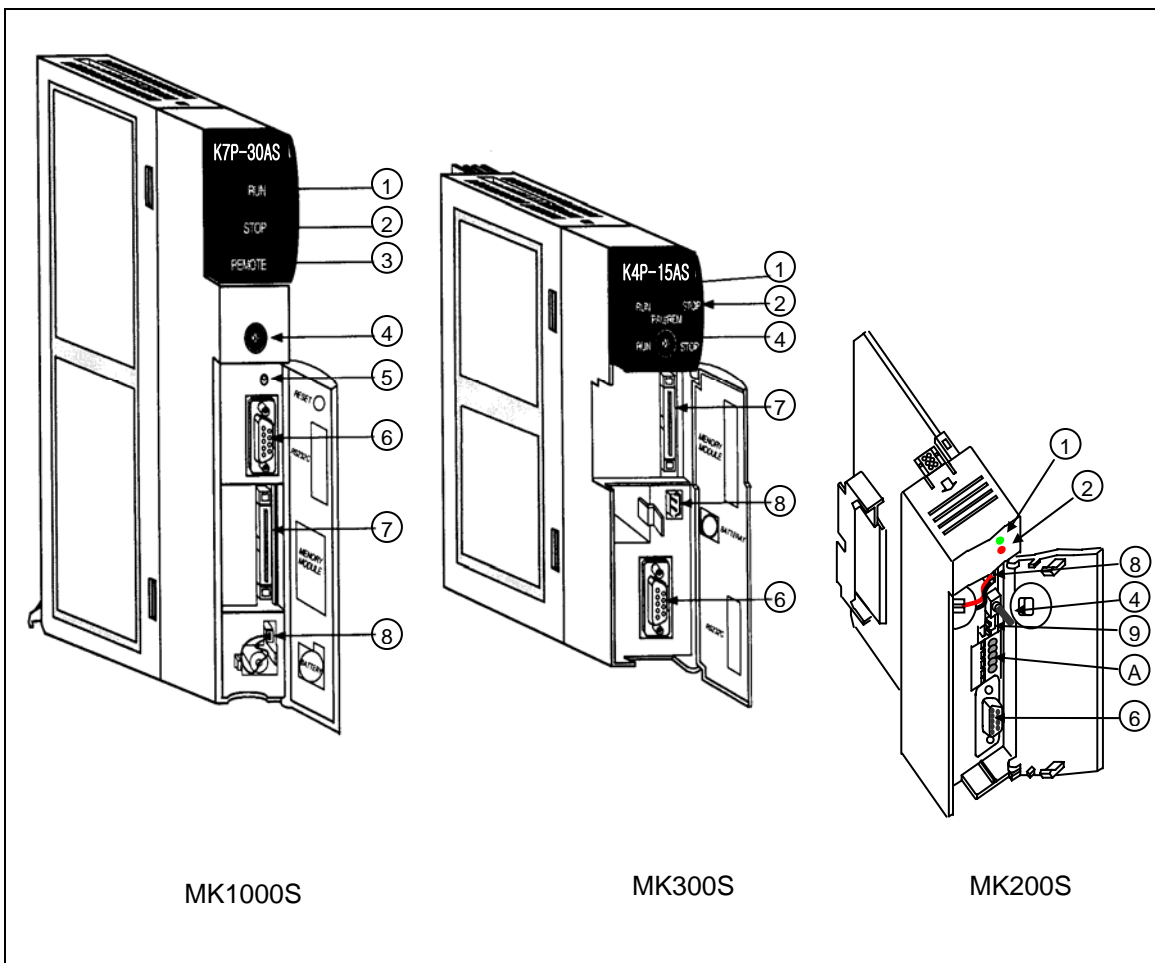

No	Name	Description
1	RUN LED	Shows the operation status of CPU module On : the CPU is on the Local RUN or remote RUN mode Off : the CPU detects improper power supply the CPU is not on the RUN mode (STOP or PAUSE mode) the CPU detects a fatal error that stop the operation
2	STOP LED	Shows the operation status of CPU module On : the CPU is on STOP mode Off : the CPU is not on the STOP mode (RUN or PAUSE) Flickering : An error is detected during operation
3	Remote LED	Only K1000S has remote LED. On : the CPU is on the remote (RUN / STOP / PAUSE / DEBUG) mode Off : the CPU is on the local (RUN / STOP / PAUSE) mode

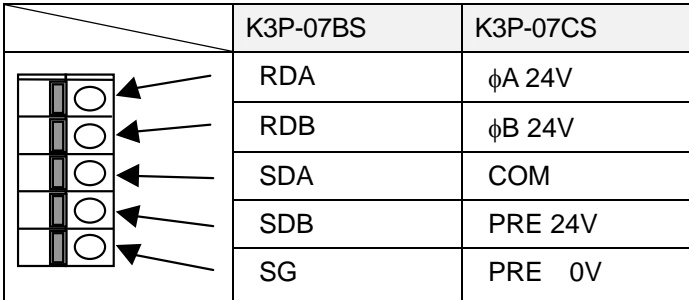
No	Name	Description																		
4	Mode key switch	Set a operation mode of CPU module - RUN : Executes user program - STOP : Stop executing user program - PAU / REM : Pause or remote mode																		
5	Manual reset switch	Restart the CPU module (Available in K1000S only)																		
6	RS-232C connector	Connector for peripheral devices uses RS-232C protocol. (Example : KGL-WIN)																		
7	Memory module connector	Connector for external memory module																		
8	Battery connector	Connector for back-up battery																		
9	Memory setting DIP switch	Refer the Chapter 6																		
A	Terminal block for special functions	K3P-07AS : Not applicable K3P-07BS : RS-422/485 interface terminal block K3P-07CS : High speed counter input terminal block  <table border="1" data-bbox="774 1050 1230 1348"> <thead> <tr> <th></th> <th>K3P-07BS</th> <th>K3P-07CS</th> </tr> </thead> <tbody> <tr> <td>RDA</td> <td></td> <td>ϕA 24V</td> </tr> <tr> <td>RDB</td> <td></td> <td>ϕB 24V</td> </tr> <tr> <td>SDA</td> <td></td> <td>COM</td> </tr> <tr> <td>SDB</td> <td></td> <td>PRE 24V</td> </tr> <tr> <td>SG</td> <td></td> <td>PRE 0V</td> </tr> </tbody> </table> <p>(Please refer chapter 13 and 16 for details)</p>		K3P-07BS	K3P-07CS	RDA		ϕ A 24V	RDB		ϕ B 24V	SDA		COM	SDB		PRE 24V	SG		PRE 0V
	K3P-07BS	K3P-07CS																		
RDA		ϕ A 24V																		
RDB		ϕ B 24V																		
SDA		COM																		
SDB		PRE 24V																		
SG		PRE 0V																		

Chapter 5 Battery

5 Battery	5-1
5.1 Specifications	5-1
5.2 Handling instructions	5-1
5.3 Replacement procedure	5-2

5 Battery

5.1 Specifications

Item	Description
Rated voltage	3.0VDC
Lifetime	5 years
Purpose	User program and data back-up, RTC operation during power-off
Type	Lithium battery, 3VDC
Dimension (mm)	φ 14.5 × 26

5.2 Handling instructions

- 1) Do not heat or solder the terminals of battery.
- 2) Do not measure its voltage with a tester, or short circuit.
- 3) Do not disassemble

Remark

The K300S and K1000S CPU modules have super capacitor to back-up during battery replacement. The super capacitor can backup the user program and latch area about 30 minutes. However, be careful to finish battery replacement as soon as possible.

Caution

The K200S CPU module does not have super capacitor or other device to backup during battery replacement. Therefore, the user program and latch area will be erased if the battery is removed while the power is off. Make sure to turn on the power of CPU during battery replacement.

5.3 Replacement procedure

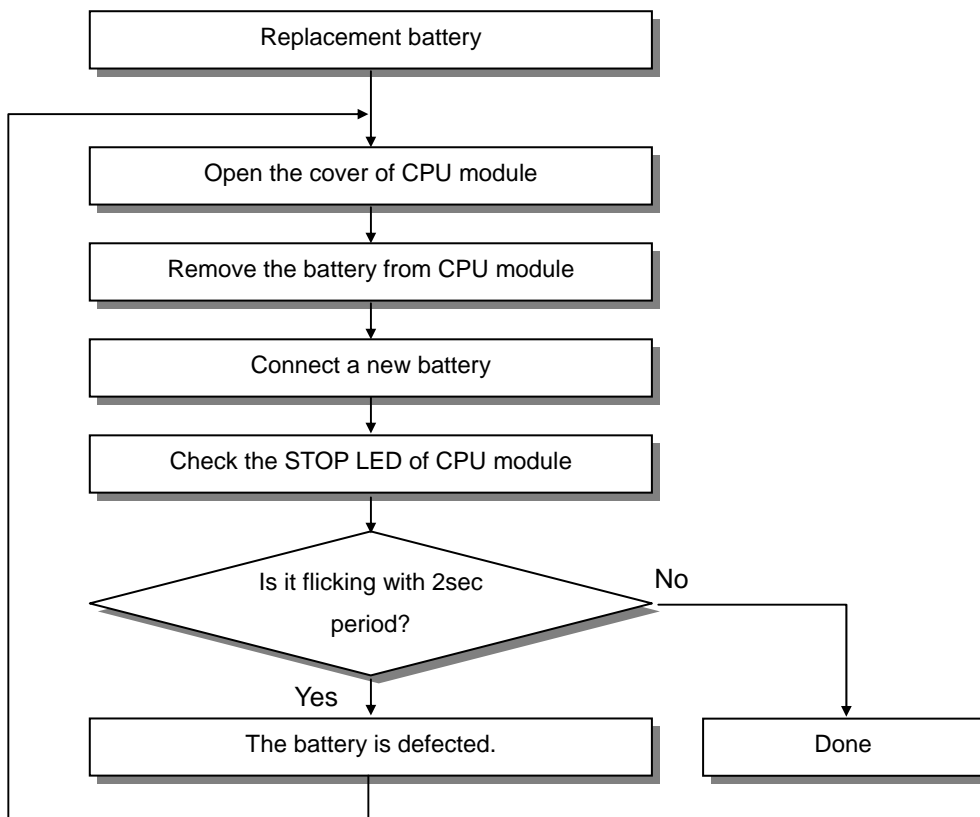

Chapter 6 Memory module

6 Memory module	6-1
6.1 Structure	6-1
6.2 Specifications	6-1
6.2.1 K300S / K1000S	6-1
6.2.2 K200S	6-2
6.3 How to use the memory module	6-2
6.3.1 Write a program into memory module	6-2
6.3.2 Execute the program of memory module.....	6-3

6 Memory module

In this chapter, it is described how to store user program in the memory module and run a PLC system with memory module.

The memory module of MASTER-K 200S/300S/1000S series uses flash memory. To read / write of memory module, insert a memory module into the memory module socket on the CPU module. No other device such as ROM writer is required.

The K200S includes a flash memory on the CPU module, so it does not have external memory module.

6.1 Structure

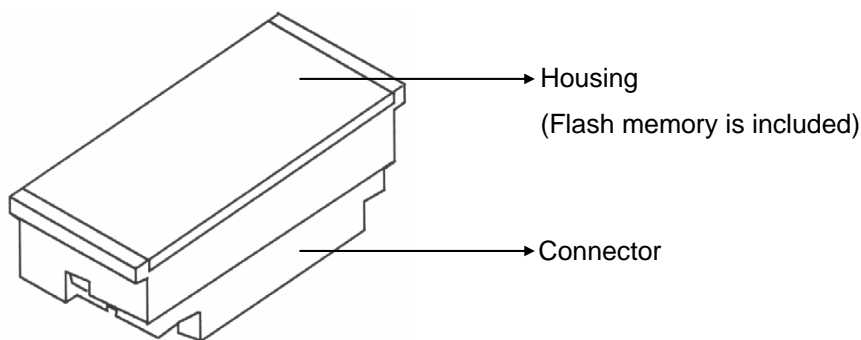

6.2 Specifications





6.2.1 K300S / K1000S

The K300S / K1000S CPU module will operate as flash memory mode automatically if the memory module is mounted in a STOP mode and then the CPU module is switched as RUN mode. The following table shows specifications of memory module of K300S / K1000S series.

Item	Type	K300S	K1000S
		K4M-32S	K764S
Memory device		Flash memory	Flash memory
Capacity		128k byte (32k steps)	256k byte (64k steps)
Weight		10g	14g

6.2.2 K200S

The K200S series includes a flash memory, and the operation mode (RAM mode / Flash memory mode) can be selected by setting DIP switch on the front of CPU module.

DIP switch setting		Description
ROM MODE  2 TEST MODE  1 \xrightarrow{N} \overline{O}	1: Off, 2: Off When the CPU starts with RUN mode, the CPU module operates with the program stored in RAM. (the contents of flash memory is ignored.)	
ROM MODE  2 TEST MODE  1 \xrightarrow{N} \overline{O}	1: Off, 2: On When the CPU starts with RUN mode, the CPU module operates with the program stored in flash memory.	

6.3 How to use the memory module

6.3.1 Write a program into memory module

When insert memory module into the memory connector of CPU module, make sure the power of CPU is turned off. To write a program on memory module, the CPU should be on STOP mode.

- 1) Download a program to be written on a memory module. (Use KGL-WIN or KLD-150S)
- 2) Switch the CPU to the STOP mode and turn off power.
- 3) Insert a memory module into the memory module connector of CPU module.
- 4) Turn on the power
- 5) Execute flash memory write function with KGL-WIN or KLD-150S.

Remark

1. Refer the user's manual of KGL-WIN or KLD-150S for details.
2. In case of K200S, switch the CPU to STOP mode and select flash memory write function of KGL-WIN or KLD-150S.

6.3.2 Execute the program of memory module

The CPU module checks the memory module is mounted or not when the CPU starts RUN mode. Then, if the memory module is mounted, the CPU module reads the program and parameter of memory module and writes it to the internal RAM of CPU module to execute the program of memory module.

The following procedure shows how to operate a CPU with flash run mode.

- 1) Switch the CPU to STOP mode and then turn off power.
- 2) Insert memory module into the memory module connector of CPU module
- 3) Turn on the power and then switch the CPU module to RUN mode.
- 4) Check the CPU is operating in flash memory mode by monitoring special relays.

F0007 : Turns on when memory module is mounted

F0005 : Turns on when the CPU operates in flash memory mode.

Remark

1. If the CPU starts RUN mode when memory module is mounted, the program and parameter of internal RAM of CPU module will be replaced with those of memory module immediately. (There is no warning message) Therefore, when write program into memory module, make sure the CPU is in STOP mode.
2. When revise program with KGL-WIN or KLD-150S, remove memory module from the memory module connector of CPU module. If the CPU is changed to RUN mode with memory module mounted, the program and parameter of CPU module is replaced as memory module and all changes of program will be lost.

Chapter 7 I/O modules

7 I/O modules.....	7-1
7.1 Notes on selecting I/O modules	7-1
7.2 Digital input modules.....	7-2
7.2.1 8 points 12/24VDC input module (source / sink type).....	7-2
7.2.2 16 points 12/24VDC input module (source/sink type).....	7-3
7.2.3 16 points 12/24 VDC input module (source type)	7-4
7.2.4 16 points 24VDC input module (source/sink type).....	7-5
7.2.5 32 points 12/24 VDC input module (source/sink type).....	7-6
7.2.6 32 points 12/24 VDC input module (source type)	7-7
7.2.7 32 points 24VDC input module (source/sink type).....	7-8
7.2.8 64 points 12/24VDC input module (source/sink type).....	7-9
7.2.9 8 points 110VAC input module	7-11
7.2.10 16 points 110VAC input module.....	7-12
7.2.11 32 points 110VAC input module.....	7-13
7.2.12 8 points 220VAC input module	7-14
7.2.13 16 points 220VAC input module	7-15
7.2.14 32 points 220VAC input module	7-16
7.2.15 Interrupt input module.....	7-17
7.3 Digital output modules	7-18
7.3.1 8 points relay output module	7-18
7.3.2 16 points relay output module	7-19
7.3.3 32 points relay output module	7-20
7.3.4 8 points triac output module	7-21
7.3.5 16 points triac output module	7-22
7.3.6 32 points triac output module	7-23
7.3.7 16 points transistor output module (sink type)	7-24
7.3.8 32 points transistor output module (sink type)	7-25
7.3.9 64 points transistor output module (sink type)	7-26
7.3.10 16 points transistor output module (source type)	7-28
7.3.11 32 points transistor output module (source type)	7-29
7.3.12 64 points transistor output module (source type)	7-30
7.4 Digital input / output hybrid modules	7-31
7.4.1 8 points 12/24VDC input + 8 points relay output.....	7-31
7.4.2 8 points 12/24VDC input + 8 points transistor output.....	7-33

7 I/O modules

7.1 Notes on selecting I/O modules

When selects I/O module for K200S/300S/1000S PLC system, please refer the following instructions.

- 1) The digital input module is classified as current sink input and current source input. The external wiring with input device is various according to the type of digital input module. Please select suitable digital input module type with considering of specification of input device.
- 2) The maximum points that can be turn simultaneously on differ with each module. Before to select a digital I/O module, check the specification of module.
- 3) When a very fast response time (less than a scan time) is required, select an interrupt module. However, only one interrupt module can be mounted on a system.
- 4) The lifetime of relay is described as total on/off times (No load : 10 million times, With load : 0.1 ~ 3 million times). Therefore, if the frequency of on/off operation of relay is higher, the lifetime of relay is shorter. Please use transistor or SSR output module for high frequency operation.
- 5) When a large and/or inductive load is connected directly to the output module, it may cause malfunction of the output module. It is highly recommended customers to connect an external relay or SSR between an output module and large inductive load for improved reliability and maintenance of PLC system.

7.2 Digital input modules

7.2.1 8 points 12/24VDC input module (source / sink type)

Specification		Type	K200S	
			G6I-D21A	
Input points		8 points		
Insulation method		Photo coupler insulation		
Rated input voltage		12VDC	24VDC	
Rated input current		3 mA	7 mA	
Operating input voltage		10.2 ~ 28.8 VDC (ripple : 5% or less)		
Max. simultaneously on		8 points (100%)		
On voltage / current		9.5 VDC or higher/ 3.5 mA		
Off voltage / current		5 VDC or less/ 1.5 mA		
Input impedance		About 3.3kΩ		
Response time	Off → On	5 msec or less		
	On → Off	5 msec or less		
Common		8 points / 1 com		
Internal current consumption		40 mA		
Operation indicator		LED display		
External wiring		9 points terminal block connector (M3×6 screw)		
Weight		120 g		
Wiring diagram				

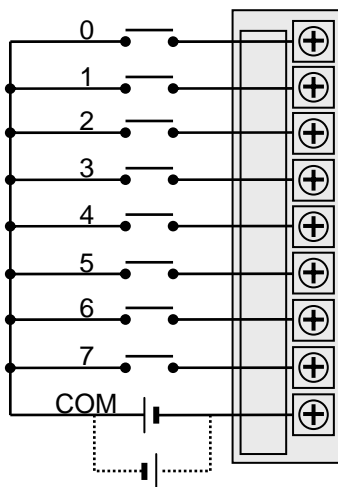

7.2.2 16 points 12/24VDC input module (source/sink type)

Specification		Type	K200S	K300S	K1000S
			G6I-D22A	G4I-D22A	G3I-D22A
Input points		16 points			
Insulation method		Photo coupler insulation			
Rated input voltage		12 / 24 VDC			
Rated input current		3 / 7 mA	5 / 11mA		
Operating input voltage		10.2 ~ 26.4 VDC (ripple : 5% or less)			
Max. simultaneously on		16 points (100%)			
On voltage / current		9.5 VDC / 3.5 mA	9.5 VDC / 4.0 mA		
Off voltage / current		5 VDC / 1.5 mA	5 VDC / 1.0 mA		
Input impedance		About 3.3kΩ	About 2.2kΩ		
Response time	Off → On	5 msec or less	10 msec or less		
	On → Off	5 msec or less	10 msec or less		
Common		8 points / 1 com			
Internal current consumption		70 mA			
Operation indicator		LED display			
External wiring		18 points terminal block connector	20 points terminal block connector		
Weight		150 g	250 g	370 g	
Wiring diagram					

7.2.3 16 points 12/24 VDC input module (source type)

Specification		Type	K200S	K300S
			G6I-D22B	G4I-D22B
Input points		16 points		
Insulation method		Photo coupler insulation		
Rated input voltage		24 VDC		12 / 24 VDC
Rated input current		7 mA		5 / 11mA
Operating input voltage		20.4~28.8 VDC (ripple: 5% or less)		10.2~26.4 VDC (ripple: 5% or less)
Max. simultaneously on		16 points (100%)		
On voltage / current		15 VDC / 4.3 mA		9.5 VDC / 4.0 mA
Off voltage / current		5 VDC / 1.7 mA		5 VDC / 1.0 mA
Input impedance		About 3.3kΩ		About 2.2kΩ
Response time	Off → On	5 msec or less		10 msec or less
	On → Off	5 msec or less		10 msec or less
Common		8 points / 1 com		
Internal current consumption		70 mA		
Operation indicator		LED display		
External wiring		20 points terminal block connector		20 points terminal block connector
Weight		150 g		250 g
Wiring diagram				

[G6I-D22B]

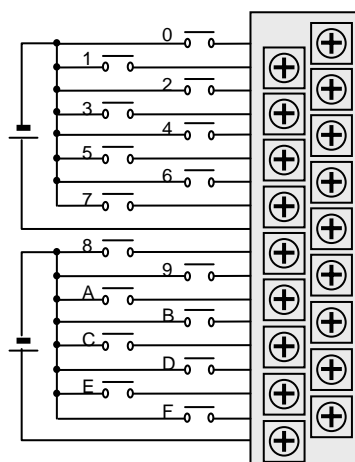

[G4I-D22B]

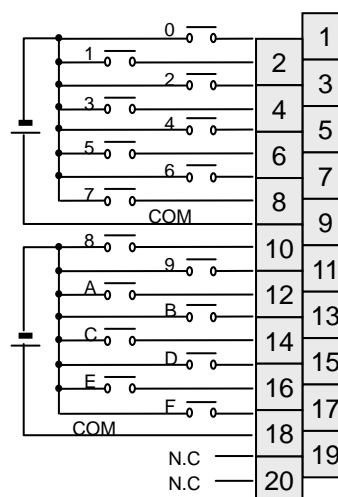

7.2.4 16 points 24VDC input module (source/sink type)

Specification		Type	K300S
			G4I-D22C
Input points		16 points	
Insulation method		Photo coupler insulation	
Rated input voltage		24 VDC	
Rated input current		7mA	
Operating input voltage		20.4 ~ 28.8 VDC (ripple : 5% or less)	
Max. simultaneously on		16 points (100%)	
On voltage / current		17 VDC / 5.2 mA	
Off voltage / current		8 VDC / 2.4 mA	
Input impedance		About 3.3kΩ	
Response time	Off → On	10 msec or less	
	On → Off	10 msec or less	
Common		8 points / 1 com	
Internal current consumption		70 mA	
Operation indicator		LED display	
External wiring		20 points terminal block connector	
Weight		250 g	
Wiring diagram			

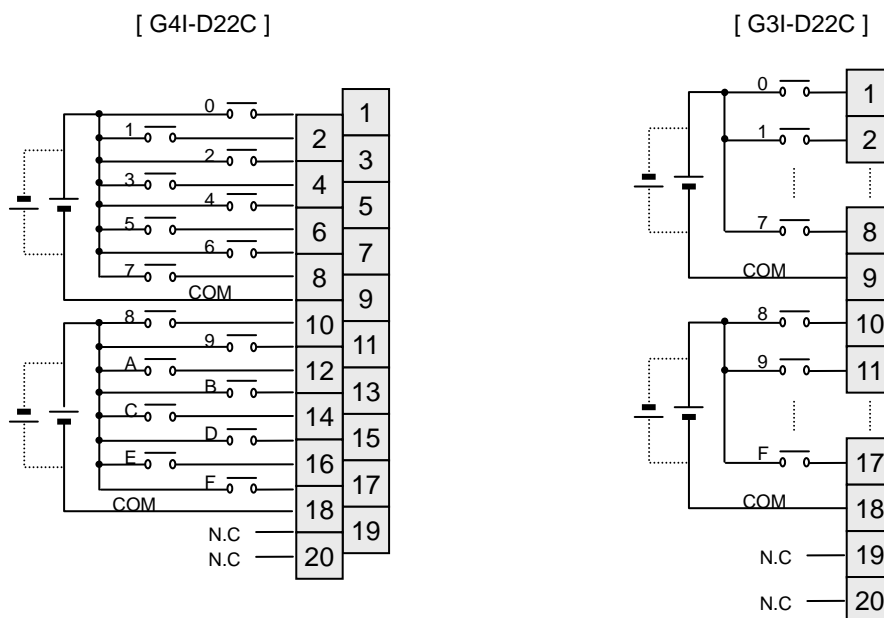

7.2.5 32 points 12/24 VDC input module (source/sink type)

Specification		Type	K200S	K300S	K1000S
			G6I-D24A	G4I-D24A	G3I-D24A
Input points		32 points			
Insulation method		Photo coupler insulation			
Rated input voltage		12 / 24 VDC			
Rated input current		3 / 7 mA			5 / 11mA
Operating input voltage		10.2 ~ 26.4 VDC (ripple: 5% or less)			
Max. simultaneously on		60% simultaneously ON			
On voltage / current		9.5 VDC / 3.5mA		9.5 VDC / 4.0 mA	
Off voltage / current		5 VDC / 1.5 mA		5 VDC / 1.0 mA	
				6VDC / 1.0 mA	
Input impedance		About 3.3kΩ		About 3.3kΩ	
				About 2.2kΩ	
Response time	Off → On	5 msec or less		10 msec or less	
	On → Off	5 msec or less		10 msec or less	
Common		32 points / 1 com			8 points / 1 com
Internal current consumption		75 mA			125 mA
Operation indicator		LED turns on at ON state of input		16-point indication by selection switch	
External wiring		37 pin D-sub connector			38 points terminal block connector
Weight		110 g		190 g	
Wiring diagram					

[G6I-D24A] & [G4I-D24A]

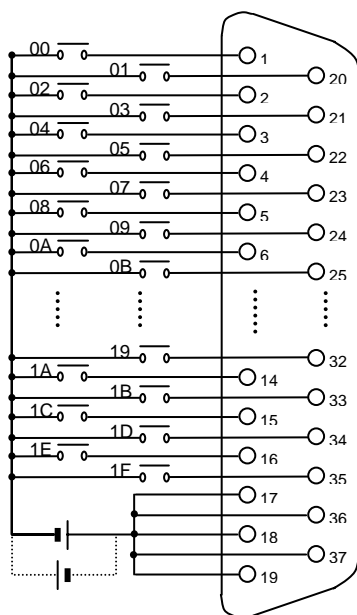

[G3I-D24A]

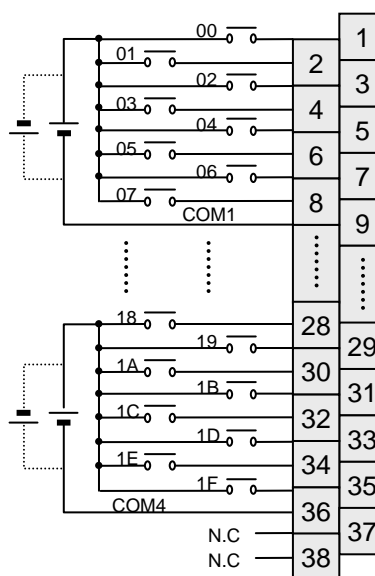

7.2.6 32 points 12/24 VDC input module (source type)

Specification		Type	K200S	K300S
			G6I-D24B	G4I-D24B
Input points		32 points		
Insulation method		Photo coupler insulation		
Rated input voltage		24 VDC	12 / 24 VDC	
Rated input current		7 mA	3 / 7 mA	
Operating input voltage		20.4~28.8VDC (ripple: 5% or less)	10.24~26.4VDC (ripple: 5% or less)	
Max. simultaneously on		19 points (60%)		
On voltage / current		15 VDC / 4.3 mA	9.5 VDC / 3.0 mA	
Off voltage / current		5 VDC / 1.7 mA	5 VDC / 1.5 mA	
Input impedance		About 3.3kΩ		
Response time	Off → On	5 msec or less	10 msec or less	
	On → Off	5 msec or less	10 msec or less	
Common		32 points / 1 com		
Internal current consumption		75 mA		
Operation indicator		LED display		
External wiring		37 pin D-sub connector		
Weight		110 g	190 g	
Wiring diagram				

7.2.7 32 points 24VDC input module (source/sink type)

Specification		Type	K300S	K1000S
			G4I-D22C	G3I-D24C
Input points		32 points		
Insulation method		Photo coupler insulation		
Rated input voltage		24 VDC		
Rated input current		11mA		
Operating input voltage		19.2 ~ 26.4 VDC (ripple: 5% or less)		
Max. simultaneously on		19 points (60%)		
On voltage / current		19.5 VDC / 4.0 mA		
Off voltage / current		15 VDC / 1.0 mA		
Input impedance		About 3.3kΩ		
Response time	Off → On	10 m sec or less		
	On → Off	10 m sec or less		
Common		32 points / 1 com	8 points / 1 com	
Internal current consumption		70 mA	125 mA	
Operation indicator		LED display		
External wiring		37 pin D-sub connector	38 points terminal block connector	
Weight		190 g	460 g	
Wiring diagram				

[G4I-D24C]

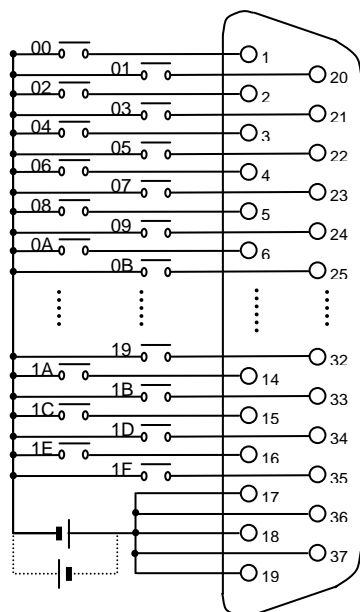

[G3I-D24C]

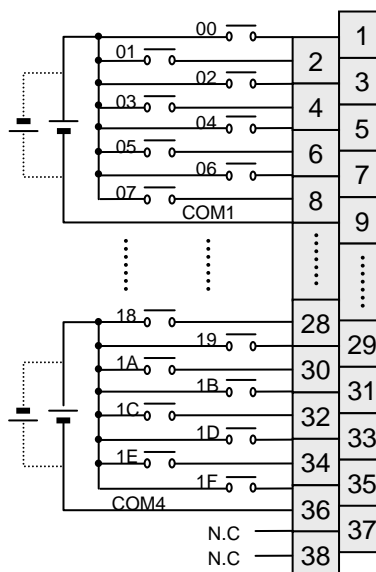

7.2.8 64 points 12/24VDC input module (source/sink type)

Specification		Type	K1000S
			G3I-D28A
Input points		64 points	
Insulation method		Photo coupler insulation	
Rated input voltage		12 / 24 VDC	
Rated input current		3 / 7 mA	
Operating input voltage		10.24 ~ 26.4 VDC (ripple: 5% or less)	
Max. simultaneously on		20 points / 1COM (60%)	
On voltage / current		9.5 VDC / 4 mA	
Off voltage / current		6 VDC / 1mA	
Input impedance		About 3.3kΩ	
Response time	Off → On	10 msec or less	
	On → Off	10 msec or less	
Common		32 points / 1 com	
Internal current consumption		120 mA	
Operation indicator		LED display	
External wiring		40-pin D-sub connector (2 connectors)	
Weight		460 g	
Wiring diagram			

Connector 1

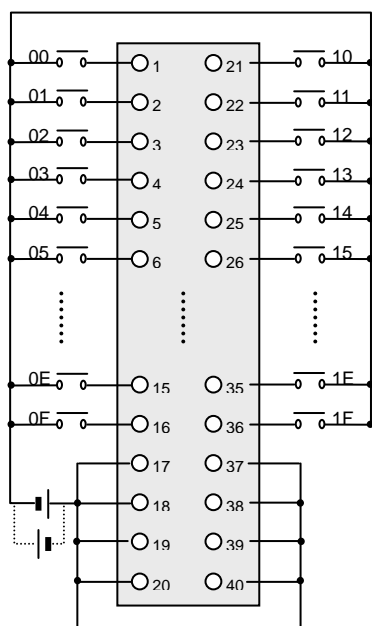

Connector 2

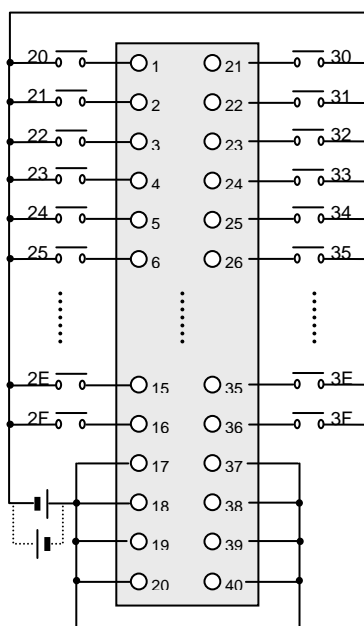

Specification		Type	K300S
		G4I-D28A	
Input points		64 points	
Insulation method		Photo coupler insulation	
Rated input voltage		12 / 24 VDC	
Rated input current		3 / 6 mA	
Operating input voltage		10.2 ~ 26.4 VDC (ripple: 5% or less)	
Max. simultaneously on		20 points / 1COM (60%)	
On voltage / current		9.5 VDC / 4mA	
Off voltage / current		5 VDC / 1 mA	
Input impedance		About 5.6 kΩ	
Response time	Off → On	10 msec or less	
	On → Off	10 msec or less	
Common		32 points / 1 com	
Internal current consumption		250 mA	
Operation indicator		LED display	
External wiring		40-pin D-sub connector (2 connectors)	
Weight		460 g	
Wiring diagram			

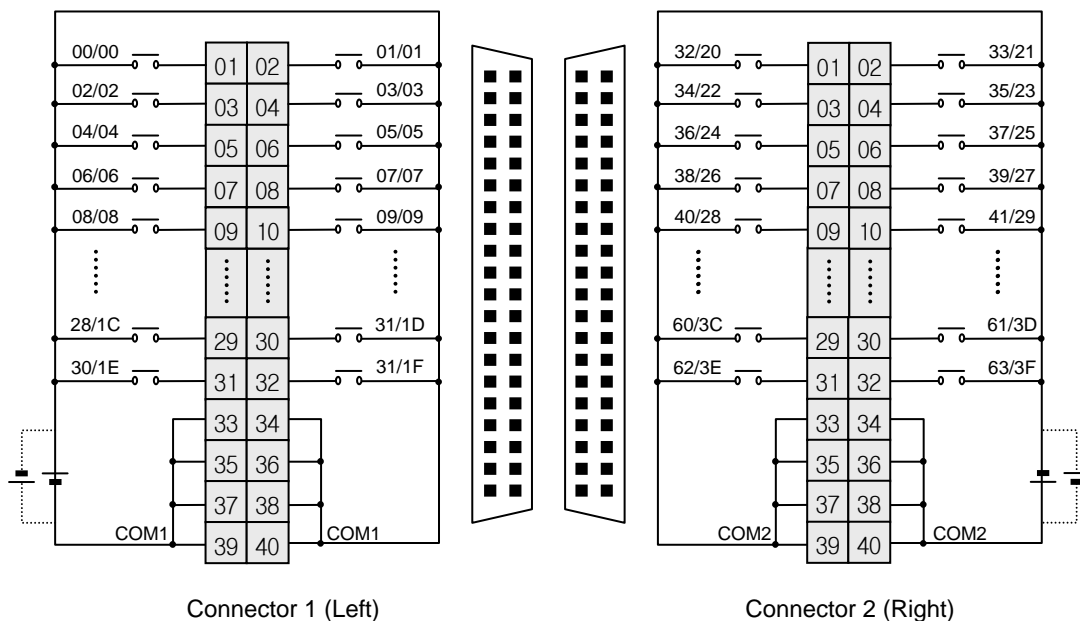

7.2.9 8 points 110VAC input module

Specification		Type	K200S
			G6I-A11A
Input points		8 points	
Insulation method		Photo coupler insulation	
Rated input voltage		110VAC (50 / 60 Hz)	
Rated input current		7 mA (110VAC, 60 Hz)	
Operating input voltage		85 ~ 132 VAC (47 ~ 63 Hz)	
Max. simultaneously on		8 points (100%)	
Inrush current		Max. 300 mA (0.3msec, 132 VAC)	
On voltage / current		80 VAC / 5 mA	
Off voltage / current		30 VAC / 2 mA	
Input impedance		About 15 kΩ	
Response time	Off → On	15 msec or less	
	On → Off	25 msec or less	
Common		8 points / 1 com	
Internal current consumption		41 mA	
Operation indicator		LED display	
External wiring		9 points terminal block connector (M3×6 screw)	
Weight		140 g	
Wiring diagram			

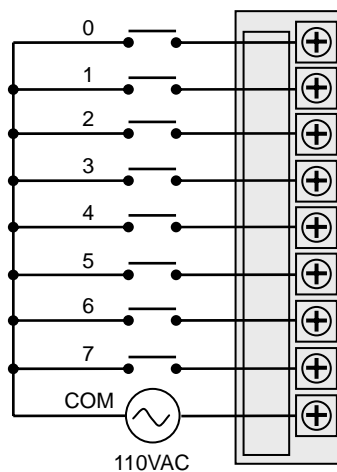

7.2.10 16 points 110VAC input module

Specification		Type	K300S	K1000S
			G4I-A12A	G3I-A12A
Input points		16 points		
Insulation method		Photo coupler insulation		
Rated input voltage		100-120VAC (50 / 60 Hz)		
Rated input current		11 mA (110VAC, 60 Hz)		
Operating input voltage		85 ~ 132 VAC (50/60 Hz ± 3 Hz)		
Max. simultaneously on		8 points / 1COM (100%)		
Inrush current		Max. 600 mA (0.3msec, 132 VAC)		
On voltage / current		80 VAC / 6 mA		
Off voltage / current		30 VAC / 3 mA		
Input impedance		About 10 kΩ		
Response time	Off → On	15 msec or less		
	On → Off	25 msec or less		
Common		8 points / 1 com		
Internal current consumption		70 mA		
Operation indicator		LED display		
External wiring		20 points terminal block connector (M3×6 screw)		
Weight		290 g	420 g	
Wiring diagram				

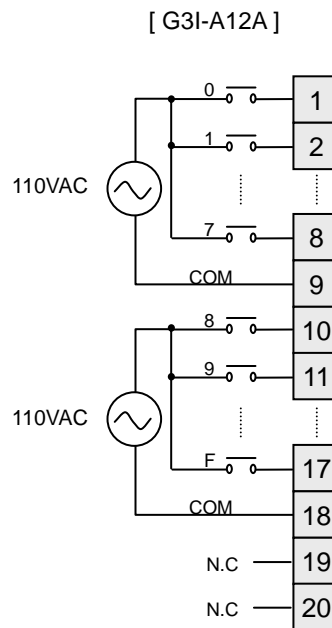
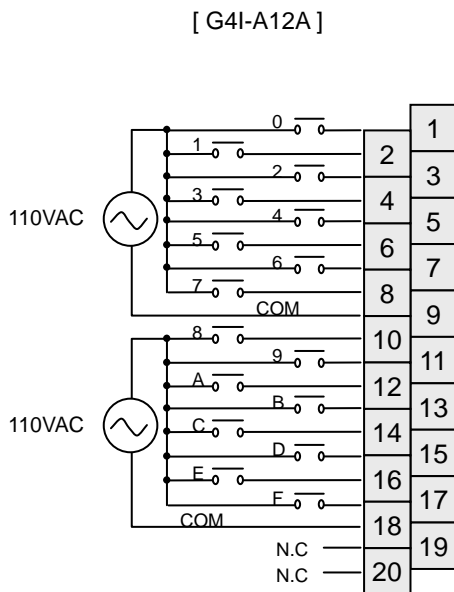

7.2.11 32 points 110VAC input module

Specification		Type	K1000S
			G3I-A14A
Input points		32 points	
Insulation method		Photo coupler insulation	
Rated input voltage		110 VAC (50 / 60 Hz)	
Rated input current		11 mA (110 VAC, 60 Hz)	
Operating input voltage		85 ~ 132 VAC (47 ~ 63 Hz)	
Max. simultaneously on		5 points / 1COM (60%)	
Inrush current		Max. 300 mA (0.3msec, 132 VAC)	
On voltage / current		80 VAC / 6 mA	
Off voltage / current		30 VAC / 3 mA	
Input impedance		About 10 kΩ	
Response time	Off → On	15 msec or less	
	On → Off	25 msec or less	
Common		8 points / 1 com	
Internal current consumption		120 mA	
Operation indicator		LED display	
External wiring		38 points terminal block connector (M3×6 screw)	
Weight		560 g	
Wiring diagram			

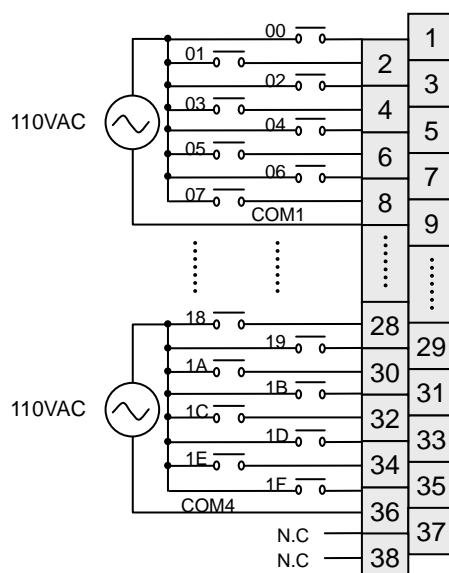

7.2.12 8 points 220VAC input module

Specification		Type	K200S
			G6I-A21A
Input points		8 points	
Insulation method		Photo coupler insulation	
Rated input voltage		200 ~ 240 VAC (50 / 60 Hz)	
Rated input current		11 mA (220VAC, 60 Hz)	
Operating input voltage		170 ~ 264 VAC (50/ 60±3Hz)	
Max. simultaneously on		8 points (100%)	
Inrush current		Max. 600 mA (0.12msec, 264 VAC)	
On voltage / current		80 VAC / 5 mA	
Off voltage / current		30 VAC / 2 mA	
Input impedance		About 20 kΩ	
Response time	Off → On	15 msec or less	
	On → Off	25 msec or less	
Common		8 points / 1 com	
Internal current consumption		40 mA	
Operation indicator		LED display	
External wiring		9 points terminal block connector (M3×6 screw)	
Weight		140 g	
Wiring diagram			

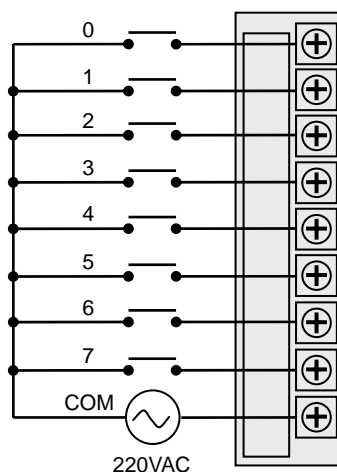

7.2.13 16 points 220VAC input module

Specification		Type	K300S	K1000S
			G4I-A22A	G3I-A22A
Input points		16 points		
Insulation method		Photo coupler insulation		
Rated input voltage		220~240 VAC (50 / 60 Hz)		
Rated input current		11 mA (220VAC/ 60 Hz)		
Operating input voltage		170 ~ 264 VAC (50 ~ 60±3 Hz)		
Max. simultaneously on		8 points / 1COM (100%)		
Inrush current		Max. 600 mA (0.12msec, 264 VAC)		
On voltage / current		80 VAC / 6 mA		
Off voltage / current		30 VAC / 3 mA		
Input impedance		About 10 kΩ		
Response time	Off → On	15 msec or less		
	On → Off	25 msec or less		
Common		8 points / 1 com		
Internal current consumption		70 mA		
Operation indicator		LED display		
External wiring		20 points terminal block connector (M3×6 screw)		
Weight		300 g	420 g	
Wiring diagram				

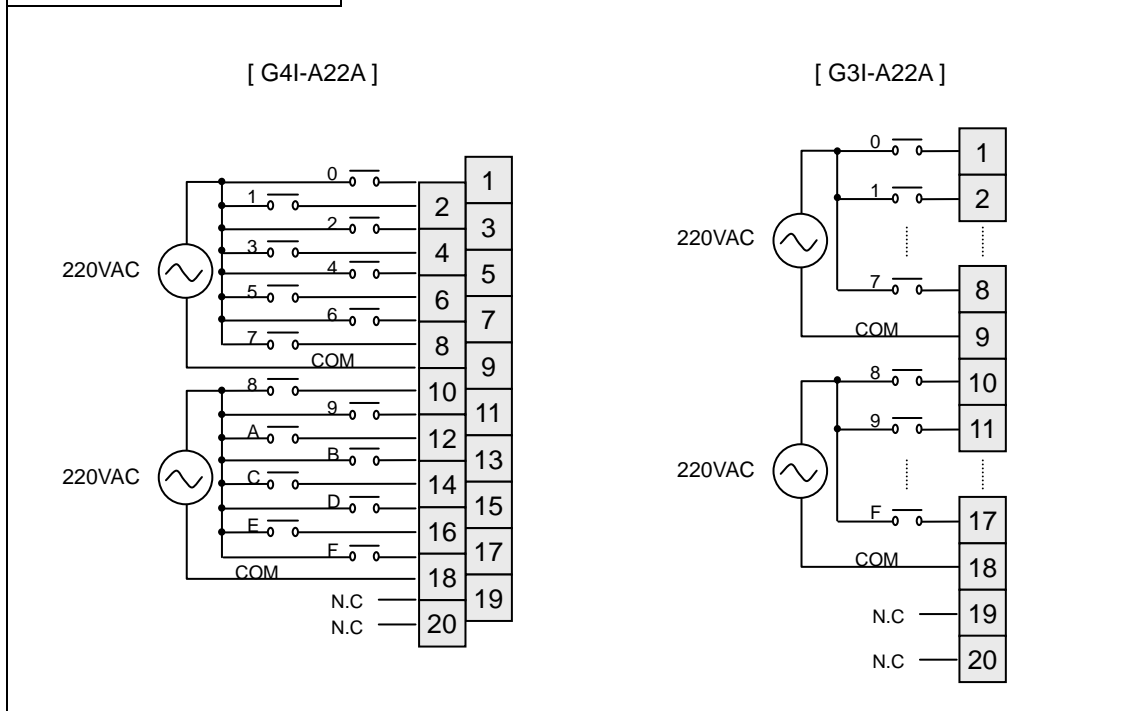

7.2.14 32 points 220VAC input module

Specification		Type	K1000S
			G3I-A24A
Input points		32 points	
Insulation method		Photo coupler insulation	
Rated input voltage		220 VAC (50 / 60 Hz)	
Rated input current		10 mA (220 VAC, 60 Hz)	
Operating input voltage		170 ~ 264 VAC (47 ~ 63 Hz)	
Max. simultaneously on		5 points / 1COM (60%)	
Inrush current		Max. 600 mA (0.12msec, 264 VAC)	
On voltage / current		150 VAC / 6 mA	
Off voltage / current		30 VAC / 3 mA	
Input impedance		About 10 kΩ	
Response time	Off → On	15 msec or less	
	On → Off	25 msec or less	
Common		8 points / 1 com	
Internal current consumption		120 mA	
Operation indicator		LED display	
External wiring		38 points terminal block connector (M3×6 screw)	
Weight		560 g	
Wiring diagram			

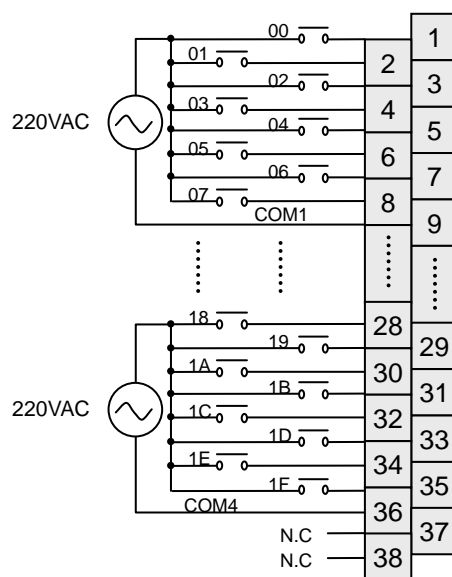

7.2.15 Interrupt input module

Specification		Type	K300S	K1000S
			G4F-INTA	G3F-INTA
Input points			8 points	16 points
Insulation method			Photo coupler insulation	
Rated input voltage			24 VDC	
Rated input current			10 mA	
Operating input voltage			21.6 ~ 26.4 VDC	
Max. simultaneously on			1 points / 1COM (100%)	
On voltage / current			15 VAC / 6.5 mA	
Off voltage / current			5 VDC / 2 mA	
Input impedance			About 2.4 kΩ	
Response time	Off → On		0.5 msec or less	
	On → Off		0.5 msec or less	
Common			1 points / 1 com	
Internal current consumption			65 mA	200 mA
Operation indicator			LED display	
External wiring			20 points terminal block connector (M3×6 screw)	38 points terminal block connector (M3×6 screw)
Weight			160 g	400 g
Wiring diagram				

[K4F-INTA]

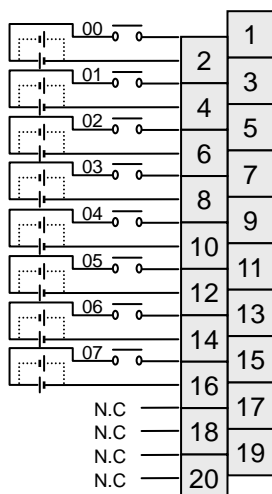

[K7F-INTA]

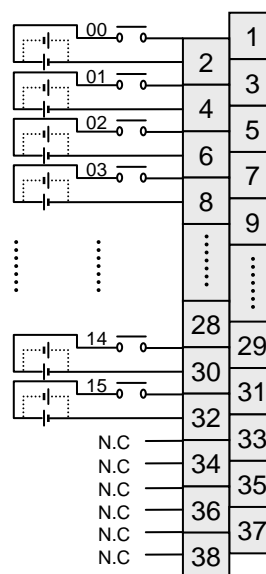

7.3 Digital output modules

7.3.1 8 points relay output module

Item	Type	K200S	
		G6Q-RY1A	
Output points	8 points		
Insulation method	Photo coupler		
Rated load voltage / current	24 VDC / 2A (resistive load), 220 VAC / 2A (cosψ = 1)		
Minimum load voltage / current	5 VDC / 1mA		
Maximum load voltage	125 VDC / 250 VAC		
Leakage current	0.1 mA (220 VAC, 60Hz)		
Maximum switching frequency	3,600 times / hour		
Surge absorber	None		
Lifetime of contact	Mechanical	No load	Over 20 million times
	Electrical	Rated voltage / current	Over 0.1 million times
		200VAC / 1.5A, 240VAC / 1A (cosψ = 0.7)	Over 0.1 million times
		200VAC / 1A, 240VAC / 0.5A (cosψ = 0.35)	Over 0.1 million times
	24VDC / 1A, 100VDC / 0.1A (L / R = 7ms)	Over 0.1 million times	
Response time	Off → On	10msec or less	
	On → Off	12msec or less	
Common method	1 point / 1COM (Independent common)		
Internal current consumption	210mA (when all outputs are on)		
Operation indicator	LED		
External wiring	18 points terminal block connector (M3×6 screw)		
Weight	160 g		
Wiring diagram			

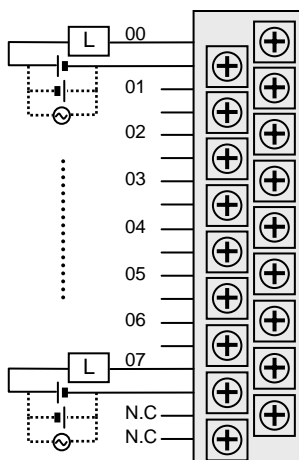

7.3.2 16 points relay output module

Item	Type	K200S	K300S	K1000S
		G3Q-RY2A	G4Q-RY2A	G3Q-RY2A
Output points	16 points			
Insulation method	Photo coupler			
Rated load voltage / current	Per 1 point	24 VDC / 2A (resistive load), 220 VAC / 2A (cosψ = 1)		
	Per 1 COM	5A / 1COM	4A / 1COM	8A / 1COM
Minimum load voltage/current	5 VDC / 1mA			
Maximum load voltage	110 VDC / 250 VAC		125 VDC / 250 VAC	
Leakage current	0.1 mA (220 VAC, 60Hz)			
Maximum switching frequency	1,200 times / hour		3,600 times / hour	
Surge absorber	None			
Lifetime of contact	Mechanical	No load	Over 20 million times	
		Rated voltage / current	Over 0.1 million times	
	Electrical	200VAC / 1.5A, 240VAC / 1A (cosψ = 0.7)	Over 0.1 million times	
		200VAC / 1A, 240VAC / 0.5A (cosψ = 0.35)	Over 0.1 million times	
		24VDC / 1A, 100VDC / 0.1A (L / R = 7ms)	Over 0.1 million times	
Response time	Off → On	10 msec or less		
	On → Off	12 msec or less		
Common method	8 point / 1COM			
Internal current consumption	400mA (all outputs on)		100mA (when all outputs are on)	
External power supply	Voltage	None		24 VDC ± 10% (ripple : 4 Vp-p or less)
	Current	None		Max. 100mA Max. 150 mA
Operation indicator	LED			
External wiring	18 points terminal block connector		20 points terminal block connector	
Weight	190 g		310 g	460 g
Wiring diagram				

[G6Q-RY2A]

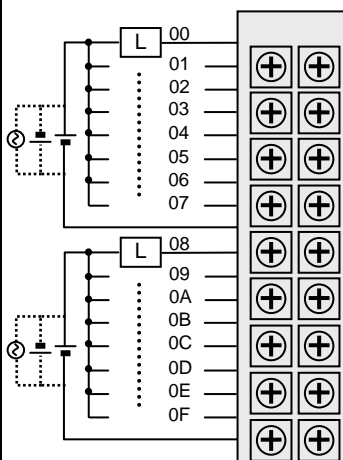

[G4Q-RY2A]

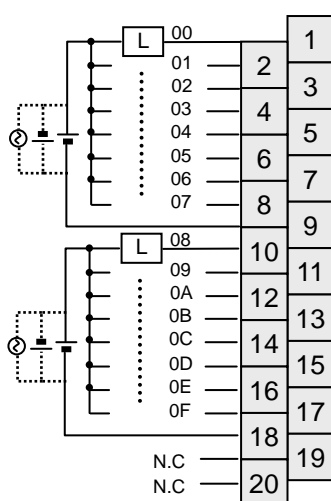

[G3Q-RY2A]

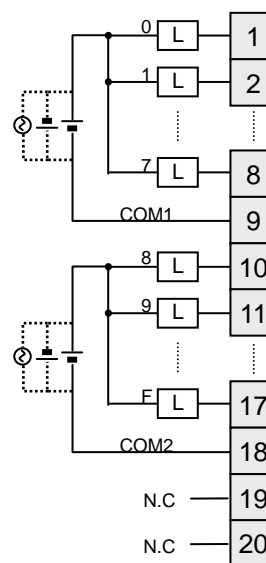

7.3.3 32 points relay output module

Item	Type	K1000S	
		G3Q-RY4A	
Output points		32 points	
Insulation method		Photo coupler	
Rated load voltage / current	Per 1 point	24 VDC / 2A (resistive load), 220 VAC / 2A (cosψ = 1)	
	Per 1 COM	5A / 1COM	
Minimum load voltage / current		5 VDC / 1mA	
Maximum load voltage		125 VDC / 250 VAC	
Leakage current		0.1 mA (220 VAC, 60Hz)	
Maximum switching frequency		3,600 times / hour	
Surge absorber		None	
Lifetime of contact	Mechanical	No load	Over 20 million times
		Rated voltage / current	Over 0.1 million times
	Electrical	200VAC / 1.5A, 240VAC / 1A (cosψ = 0.7)	Over 0.1 million times
		200VAC / 1A, 240VAC / 0.5A (cosψ = 0.35)	Over 0.1 million times
Response time	Off → On	10 msec or less	
	On → Off	12 msec or less	
Common method		8 point / 1COM	
Internal current consumption		200mA (when all outputs are on)	
External power supply	Voltage	24 VDC ± 10% (ripple : 4 Vp-p or less)	
	Current	Max. 170 mA	
Operation indicator		LED	
External wiring		38 points terminal block connector	
Weight		550 g	
Wiring diagram			

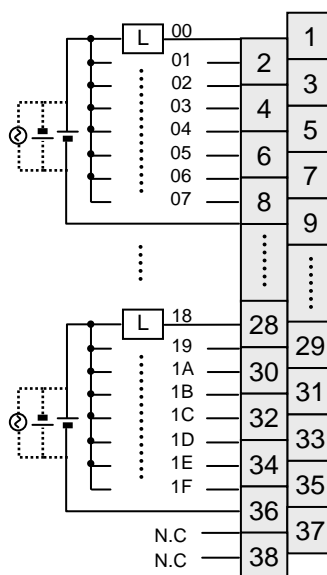

7.3.4 8 points triac output module

Item	Type	K200S
		G6Q-SS1A
Output points		8 points
Insulation method		Photo coupler
Rated load voltage		100 ~ 240 VAC (50 / 60 Hz)
Maximum load voltage		264 VAC
Maximum load current	Per 1point	1 A
	Per 1 COM	4 A
Minimum load current		20 mA
Leakage current		2.5 mA (220 VAC, 60Hz)
Maximum inrush current		40 A, (10 msec or less)
On state voltage drop		2.5 VAC or less (2 A)
Surge absorber		Varistor (387 ~ 473 V), C-R absorber
Response time	Off → On	1 msec or less
	On → Off	1/2 cycle + 1 msec or less
Common method		8 point / 1COM
Internal current consumption		210 mA (when all outputs are on)
Operation indicator		LED
External wiring		9 points terminal block connector (M3×6 screw)
Weight		160 g
Wiring diagram		

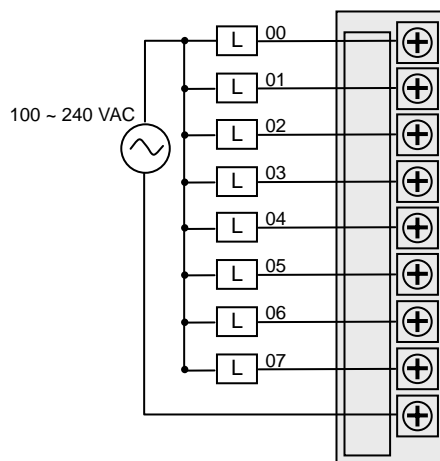

7.3.5 16 points triac output module

Item	Type	K300S		K1000S
		G4Q-SS2A	G4Q-SS2B	G3Q-SS2A
Output points		16 points		
Insulation method		Photo coupler		
Rated load voltage		100 ~ 240 VAC (50 / 60 Hz)		
Maximum load voltage		264 VAC		
Maximum load current	Per 1point	1 A	0.6 A	2 A
	Per 1 COM	5 A	2.4 A	5 A
Minimum load current		20mA	10mA	20mA
Leakage current		2.5 mA (220 VAC, 60Hz)		
Maximum inrush current		25A, 10msec or less	20A, 10msec or less	40A, 10msec or less
On state voltage drop		1.5 VAC or less (1A)	1.5VAC or less (0.6A)	1.5VAC or less (2A)
Surge absorber		Varistor (387 ~ 473 V), C-R absorber		
Response time	Off → On	1/2 cycle + 1 msec or less		
	On → Off	1/2 cycle + 1 msec or less		
Common method		8 points / 1COM		
Internal current consumption		330 mA (when all outputs are on)		
Operation indicator		LED		
External wiring		20 points terminal block connector (M3×6 screw)		
Weight		350 g		500 g
Wiring diagram				

[G4Q-SS2A & G4Q-SS2B]

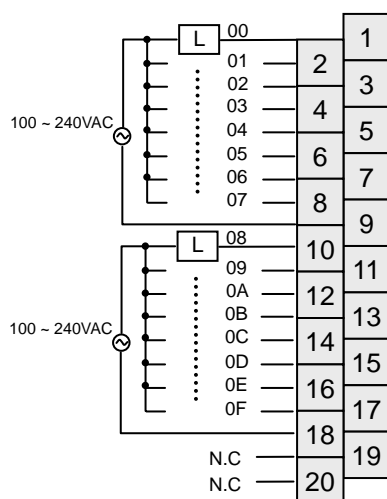

[G3Q-SS2A]

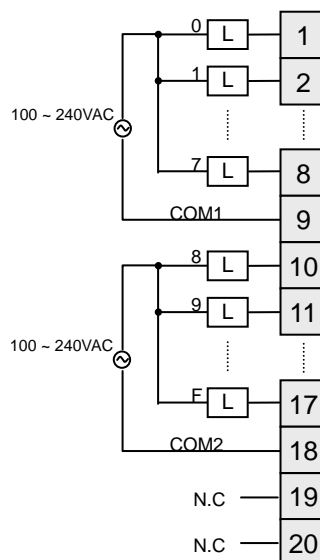

7.3.6 32 points triac output module

Item	Type	K1000S	
		G3Q-SS4A	
Output points	32 points		
Insulation method	Photo coupler		
Rated load voltage	100 ~ 240 VAC (50 / 60 Hz)		
Maximum load voltage	264 VAC		
Maximum load current	Per 1point	1 A	
	Per 1 COM	5 A	
Minimum load current	20 mA		
Leakage current	2.5 mA (220 VAC, 60Hz)		
Maximum inrush current	25 A, (10 msec or less)		
On state voltage drop	1.5 VAC or less (1 A)		
Surge absorber	Varistor (387 ~ 473 V), C-R absorber		
Response time	Off → On	1 msec or less	
	On → Off	1/2 cycle + 1 msec or less	
Common method	8 point / 1COM		
Internal current consumption	600 mA (when all outputs are on)		
Operation indicator	LED		
External wiring	38 points terminal block connector (M3×6 screw)		
Weight	600 g		
Wiring diagram			

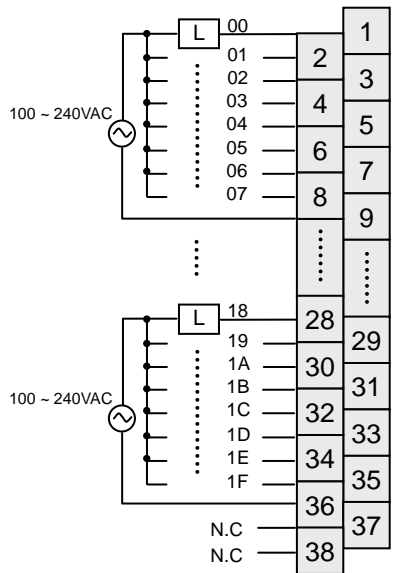

7.3.7 16 points transistor output module (sink type)

Item		Type	K200S	K300S	K1000S
			G6Q-TR2A	G4Q-TR2A	G3Q-TR2A
Output points		16 points			
Insulation method		Photo coupler			
Rated load voltage		12 / 24 VDC			
Maximum load current	Per 1 point	0.5 A / 1 point		2 A / 1 point	
	Per 1 COM	5 A / 1COM	4 A / 1COM	8 A / 1COM	
Leakage current		0.1 mA			
Maximum inrush current		4 A, 10 msec or less		8 A, 10 msec or less	
On state voltage drop		1.5 VDC or less			
Surge absorber		Clamp diode	Varistor	Clamp diode	
Response time	Off → On	2 msec or less			
	On → Off	2 msec or less			
Common method		16 point / 1COM	8 point / 1COM		
Internal current consumption		180mA (all outputs are on)	110mA (all outputs are on)	120mA (all outputs are on)	
External power supply	Voltage	24 VDC ± 10% (ripple : 4 Vp-p or less)			
	Current	Max. 48mA per 1com	Max. 100mA per 1com		
Operation indicator		LED			
External wiring		18 points terminal block connector	20 points terminal block connector		
Weight		180 g	270 g	540 g	
Wiring diagram					

[G6Q-TR2A]

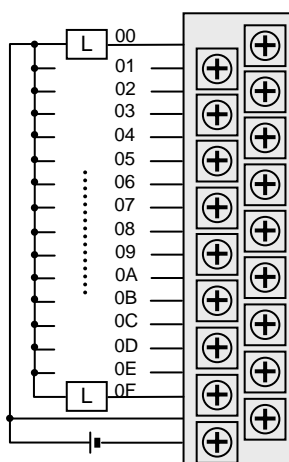

[G4Q-TR2A]

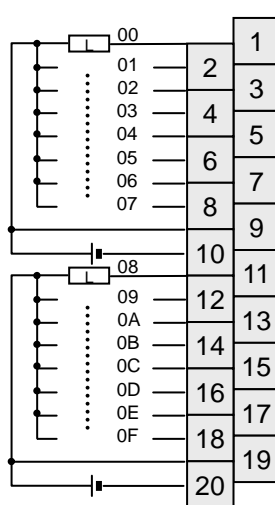

[G3Q-TR2A]

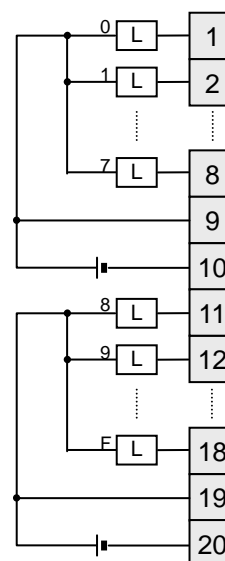

7.3.8 32 points transistor output module (sink type)

Item		Type	K200S	K300S	K1000S
			G6Q-TR4A	G4Q-TR4A	G3Q-TR4A
Output points		32 points			
Insulation method		Photo coupler			
Rated load voltage		12 / 24 VDC			
Maximum load current	Per 1 point	0.1 A / 1 point	0.1 A / 1 point	0.5 A / 1 point	
	Per 1 COM	2 A / 1COM	2 A / 1COM	3 A / 1COM	
Leakage current		0.1 mA			
Maximum inrush current		0.4 A, 10 msec or less	4 A, 10 msec or less	4 A, 10 msec or less	
On state voltage drop		2.0 VDC or less	1.0 VDC or less	1.5 VDC or less	
Surge absorber		Clamp diode			
Response time	Off → On	2 msec or less			
	On → Off	2 msec or less			
Common method		32 point / 1COM			16 point / 1COM
Internal current consumption		180mA (all outputs are on)	110mA (all outputs are on)	120mA (all outputs are on)	
External power supply	Voltage	10.2 ~ 26.4 VDC	24 VDC ± 10% (ripple : 4 Vp-p or less)		
	Current	Max. 36mA per 1com	Max. 150mA per 1com		
Operation indicator		LED			
External wiring		32 Pin D-sub connector			38 points terminal block connector
Weight		110 g	180 g	500 g	
Wiring diagram		<div style="display: flex; justify-content: space-around;"> <div style="text-align: center;"> <p>[G6Q-TR4A & G4Q-TR4A]</p> </div> <div style="text-align: center;"> <p>[G3Q-TR4A]</p> </div> </div>			

7.3.9 64 points transistor output module (sink type)

Item	Type	K1000S
		G3Q-TR8A
Output points		64 points
Insulation method		Photo coupler
Rated load voltage		12 / 24 VDC
Operating load voltage		10.2 ~ 26.4 VDC
Maximum load current	Per 1 point	0.1 A / 1 point
	Per 1 COM	2 A / 1COM
Leakage current		0.1 mA
Maximum inrush current		0.4 A, /10 msec or less
On state voltage drop		1.0 VDC or less
Surge absorber		None
Response time	Off → On	2 msec or less
	On → Off	2 msec or less
Common method		32 point / 1COM
Internal current consumption		250mA (all outputs are on)
External power supply	Voltage	10.2 ~ 26.4 VDC
	Current	170mA or less (24VDC/1 Com)
Operation indicator		LED
External wiring		40 pin D-sub connector (2 connectors)
Weight		400 g
Wiring diagram		

[Connector 1]

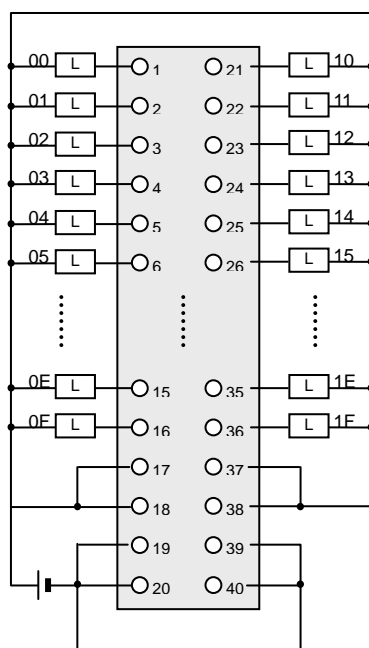

[Connector 2]

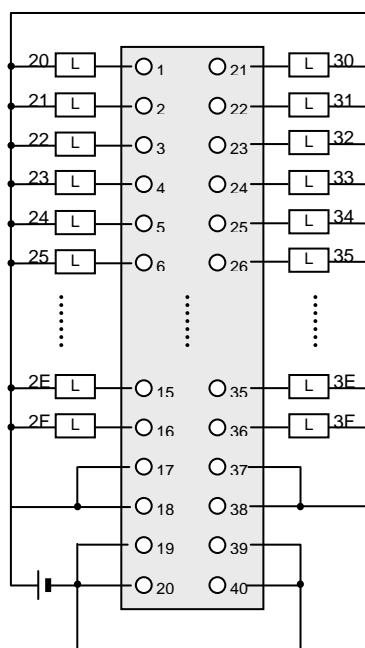

Item	Type	K300S
		G4Q-TR8A
Output points		64 points
Insulation method		Photo coupler
Rated load voltage		12 / 24 VDC
Operating load voltage		10.2 ~ 26.4 VDC
Maximum load current	Per 1 point	0.1 A / 1 point
	Per 1 COM	2 A / 1COM
Leakage current		0.1 mA
Maximum inrush current		0.4 A, 10 msec or less
On state voltage drop		1.0 VDC or less
Surge absorber		None
Response time	Off → On	2 msec or less
	On → Off	2 msec or less
Common method		32 point / 1COM
Internal current consumption		250mA (all outputs are on)
External power supply	Voltage	10.2 ~ 26.4 VDC
	Current	Max. 100mA per 1com (24VDC)
Operation indicator		LED
External wiring		40 Pin D-sub connector (2 connectors)
Weight		400 g
Wiring diagram		

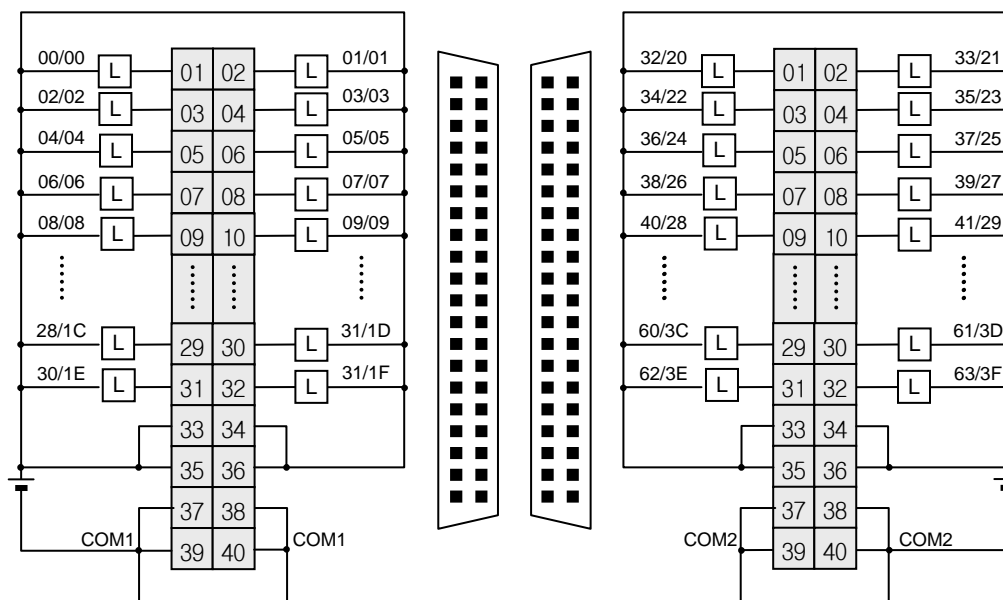

Connector 1 (Left)

Connector 2 (Right)

7.3.10 16 points transistor output module (source type)

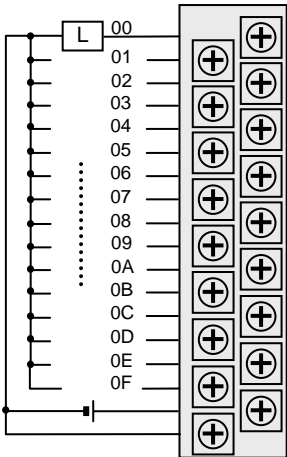
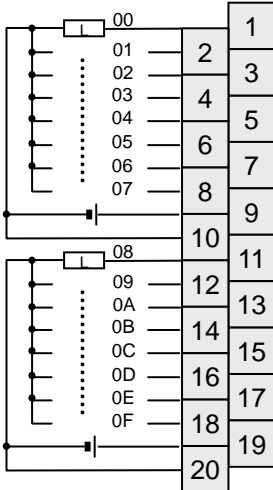
Item	Type	K200S	K300S
		G6Q-TR2B	G4Q-TR2B
Output points		16 points	
Insulation method		Photo coupler	
Rated load voltage		12 / 24 VDC	
Operating load voltage		10.2 ~ 26,4 VDC	
Maximum load current	Per 1 point	0.5 A / 1 point	
	Per 1 COM	4 A / 1COM	3 A / 1COM
Leakage current		0.1 mA	
Maximum inrush current		4 A, 10 msec or less	
On state voltage drop		1.5 VDC or less	
Surge absorber		Clamp diode	Varistor
Response time	Off → On	2 msec or less	
	On → Off	2 msec or less	
Common method		16 point / 1COM	8 point / 1COM
Internal current consumption		180mA (all outputs are on)	110mA (all outputs are on)
External power supply	Voltage	24 VDC ± 10% (ripple : 4 Vp-p or less)	
	Current	Max. 48mA per 1com	Max. 100mA per 1com
Operation indicator		LED	
External wiring		18 points terminal block connector	20 points terminal block connector
Weight		180 g	270 g
Wiring diagram	<div style="display: flex; justify-content: space-around;"> <div style="text-align: center;"> <p>[G6Q-TR2B]</p>  </div> <div style="text-align: center;"> <p>[G4Q-TR2B]</p>  </div> </div>		

7.3.11 32 points transistor output module (source type)

Item	Type	K200S	K300S	K1000S
		G6Q-TR4B	G4Q-TR4B	G3Q-TR4B
Output points		32 points		
Insulation method		Photo coupler		
Rated load voltage		12 / 24 VDC		
Maximum load current	Per 1 point	0.1 A / 1 point	0.1 A / 1 point	0.5 A / 1 point
	Per 1 COM	2 A / 1COM	2 A / 1COM	3 A / 1COM
Leakage current		0.1 mA		
Maximum inrush current		0.4 A, 10 msec or less	4 A, 10 msec or less	4 A, 10 msec or less
On state voltage drop		2.0 VDC or less	1.0 VDC or less	1.5 VDC or less
Surge absorber		Clamp diode		
Response time	Off → On	2 msec or less		
	On → Off	2 msec or less		
Common method		32 point / 1COM		16 point / 1COM
Internal current consumption		180mA (all outputs are on)	110mA (all outputs are on)	120mA (all outputs are on)
External power supply	Voltage	10.2 ~ 26.4 VDC	24 VDC ± 10% (ripple : 4 Vp-p or less)	
	Current	Max. 36mA per 1com	Max. 150mA per 1com	
Operation indicator		LED		
External wiring		32 Pin D-sub connector		38 points terminal block connector
Weight		110 g	180 g	500 g
Wiring diagram				

[G6Q-TR4B & G4Q-TR4B]

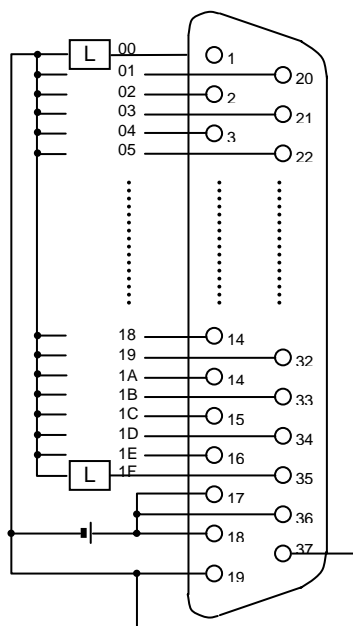

[G3Q-TR4B]

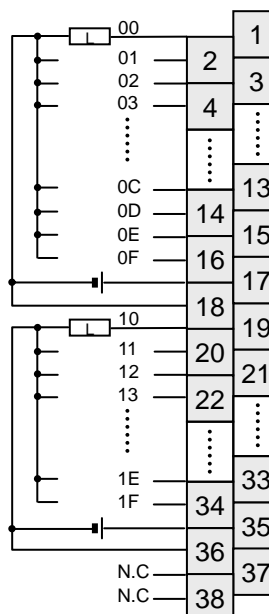

7.3.12 64 points transistor output module (source type)

Item	Type	K1000S
		G3Q-TR8B
Output points		64 points
Insulation method		Photo coupler
Rated load voltage		12 / 24 VDC
Operating load voltage		10.2 ~ 26.4 VDC
Maximum load current	Per 1 point	0.1 A / 1 point
	Per 1 COM	2 A / 1COM
Leakage current		0.1 mA
Maximum inrush current		0.4 A, 10 msec or less
On state voltage drop		1.0 VDC or less
Surge absorber		None
Response time	Off → On	2 msec or less
	On → Off	2 msec or less
Common method		32 point / 1COM
Internal current consumption		300mA (all outputs are on)
External power supply	Voltage	10.2 ~ 26.4 VDC
	Current	Max. 100mA per 1com (24VDC)
Operation indicator		LED
External wiring		40 Pin D-sub connector (2 connectors)
Weight		420 g
Wiring diagram		

[Connector 1]

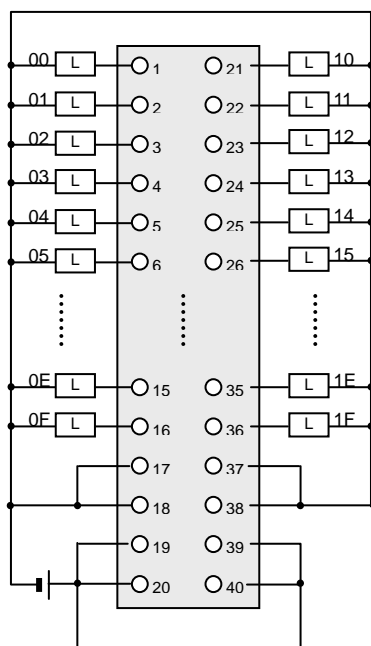

[Connector 2]

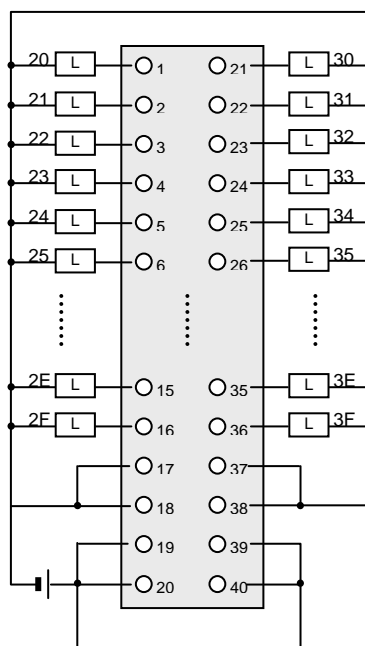

7.4 Digital input / output hybrid modules

7.4.1 8 points 12/24VDC input + 8 points relay output

K200S					
G6H-DR2A					
Input			Output		
Input point	8 points		Output points	8 points	
Insulation method	Photo coupler insulation		Insulation method	Relay insulation	
Rated input voltage	DC12 / 24V		Rated load voltage / current	24 VDC / 2A (resistive load), 220 VAC / 2A (cosψ = 1)	
Rated input current	3 / 7 mA		Min. load voltage / current	DC5V / 1 mA	
Operating voltage	DC10.2~26.4V		Max. load voltage / current	AC250V, DC125V	
Max. simultaneously on	100% simultaneously on		Leakage current	0.1 mA (AC220V, 60Hz)	
On voltage / current	9.5 VDC / 3.0 mA		Max. switching frequency	1.200 times / hour	
Off voltage / current	5 VDC / 1.5 mA		Surge absorber	None	
Input impedance	About 3.3 kΩ		Lifetime of contact	Mechanical	Same as G6Q-RY2A
Response time	Off → On	5 ms or less		Response time	
	On → Off	7 ms or less	Off → On		
Common	8 points / 1COM		On → Off	12 ms or less	
-	-		Common	8 points / 1COM	
Operation Indicator	LED				
External wiring	18 points terminal block connector (M3 × 6 screw)				
Internal current consumption	250 mA				
Weight	0.20 kg				
Wiring					

K300S				
G4H-DR2A				
Input			Output	
Input point	8 points		Output points	8 points
Insulation method	Photo coupler insulation		Insulation method	Photo coupler insulation
Rated input voltage	12 / 24VDC		Rated load voltage / current	24 VDC / 2A (resistive load), 220 VAC / 2A (cosφ = 1)
Rated input current	5 / 11 mA		Min. load voltage / current	DC5V / 1 mA
Operating voltage	10.2~26.4VDC		Max. load voltage / current	AC250V, DC125V
Max. simultaneously on	100% simultaneously on		Leakage current	0.1 mA (AC220V, 60Hz)
On voltage / current	9.5 VDC / 4.0 mA		Max. switching frequency	1,200 times / hour
Off voltage / current	6 VDC / 1.0 mA		Surge absorber	None
Input impedance	About 2.2 kΩ		Lifetime of contact	Mechanical
Response time	Off → On	10 ms or less	Response time	Electrical
	On → Off	10 ms or less		Off → On
Common	8 points / 1COM		On → Off	12 ms or less
-	-	-	Common	8 points / 1COM
-	-	-	External power supply	Voltage
-	-	-		Current
Operation Indicator	LED			
External wiring	20 points terminal block connector (M3 × 6 screw)			
Internal current consumption	100 mA			
Weight	0.26 kg			
Wiring				

7.4.2 8 points 12/24VDC input + 8 points transistor output

K300S					
G4H-DT2A					
Input			Output		
Input point	8 points		Output points	8 points	
Insulation method	Photo coupler insulation		Insulation method	Photo coupler insulation	
Rated input voltage	DC12 / 24V		Rated load voltage	DC12 / 24V	
Rated input current	5 / 11 mA		Operating load voltage	DC10.2 ~ 26.4V	
Operating voltage	DC10.2~26.4V		Max. load current	0.5A / 1 point, 3A / 1COM	
Max. simultaneously on	100% simultaneously on		Leakage current	0.1 mA (AC220V, 60Hz)	
On voltage / current	9.5 VDC / 4.0 mA		Max. inrush current	4A / 10ms or less	
Off voltage / current	5 VDC / 1.0 mA		On state voltage drop	1.5 VDC or less	
Input impedance	About 2.2 kΩ		Surge absorber	Varistor	
Response time	Off → On	10 ms or less	Response time	Off → On	2 ms or less
	On → Off	10 ms or less		On → Off	2 ms or less
Common	8 points / 1COM		Common	8 points / 1COM	
-	-	-	External power supply	Voltage	DC24V ± 10%
-	-	-		Current	50 mA
Operation Indicator	LED				
External wiring	20 points terminal block connector (M3×6 screw)				
Internal consumption current	100 mA				
Weight	0.26 kg				
Wiring					

Chapter 8 Power supply modules

8 Power supply modules	8-1
8.1 Selection of power supply module	8-1
8.1.1 K200S	8-1
8.1.2 K300S	8-2
8.1.3 K1000S	8-3
8.2 Specifications	8-4
8.2.1 K200S series.....	8-4
8.2.2 K300S series.....	8-5
8.2.3 K1000S series.....	8-5
8.3 Parts names and descriptions	8-6

8 Power supply modules

In this chapter, it will be described that the power supply modules of MASTER-K series.

8.1 Selection of power supply module

When select a power supply module of PLC system, it should be considered that the total current consumption of CPU module, digital I/O modules, special purpose modules, and communication modules. If the power capacity of power supply module is smaller than the total current consumption of PLC system, it may cause a malfunction on operation. The following table shows a current consumption of MASTER-K 200S/300S/1000S series.

8.1.1 K200S

(unit : mA)

Module	Catalog No.	Current consumption	Module	Catalog No.	Current consumption
CPU	K3P-07AS	170	A/D conversion	G6F-AD2A	50
	K3P-07BS	210	D/A conversion	G6F-DV2A	50
	K3P-07CS	170		G6F-DI2A	50
12/24VDC input	G6I-D21A	40	High speed counter	G6F-HSCA	220
	G6I-D22A	70	Positioning	G6F-POPA	345
	G6I-D22B	70	Cnet link	G6L-CU2A	140
	G6I-D24A	75		G6L-CU4A	180
	G6I-D24B	75	Fnet I/F	G6L-FUEA	215
110VAC input	G6I-A11A	41	Fnet remote I/F	G6L-RBEA	215
220VAC input	G6I-D21A	41			
Relay output	G6Q-RY1A	210			
	G6Q-RY2A	400			
Transistor output	G6Q-TR2A	180			
	G6Q-TR2B	170			
	G6Q-TR4A	140			
	G6Q-TR4B	145			
Triac output	G6Q-SS1A	190			
12/24VDC input + Relay output	G6H-DR2A	270			

8.1.2 K300S

Module	Catalog No.	Current consumption	Module	Catalog No.	Current consumption
CPU	K4P-15AS	130	A/D conversion	G4F-AD2A	400
12/24VDC input	G4I-D22A	70		G4F-AD3A	500
	G4I-D22B	70	D/A conversion	G4F-DA1A	450
	G4I-D24A	125		G4F-DV2A	400
	G4I-D24B	125		G4F-DI2A	680
	G4I-D28A	250		G4F-DV3A	700
24VDC input	G4I-D22C	70		G4F-DI3A	60
	G4I-D24C	125	High speed counter	G4F-HSCA	300
110VAC input	G4I-A12A	70	Positioning	G4F-POPA	400
220VAC input	G4I-A22A	70		G4F-POPB	400
Relay output	G4Q-RY2A	100	Thermo couple	G4F-TC2A	450
Triac output	G4Q-SS2A	330	RTD	G4F-RD2A	600
	G4Q-SS2B	330	PID control	G4F-PIDA	200
Transistor output	G4Q-TR2A	120	Analog timer	G4F-AT3A	00
	G4Q-TR2B	120	Cnet link	G4L-CUEA	100
	G4Q-TR4A	160	Fnet I/F	G4L-FUEA	160
	G4Q-TR4B	160	Fnet remote I/F	G4L-RBEA	150
	G4Q-TR8A	320			
Interrupt input	G4F-INTA	65			
12/24VDC input + Relay output	G4H-DR2A	170			
12/24VDC input + TR output	G4H-DT2A	190			

8.1.3 K1000S

Module	Catalog No.	Current consumption	Module	Catalog No.	Current consumption
CPU	K7P-30AS	130	A/D conversion	G3F-AD4A	700
12/24VDC input	G3I-D22A	70		G3F-AD4B	540
	G3I-D24A	125		G3F-AD3A	500
24VDC input	G3I-D24B	120	D/A conversion	G3F-DV4A	350
	G3I-D24C	125		G3F-DI4A	250
110VAC input	G3I-A12A	70		G3F-DV3A	700
	G3I-A14A	120	G3F-DI3A	60	
220VAC input	G3I-A22A	70	High speed counter	G3F-HSCA	300
	G3I-A24A	120	Positioning	G3F-POPA	400
Relay output	G3Q-RY2A	100		G3F-POAA	700
	G3Q-RY4A	200	Thermo couple	G3F-TC4A	450
Triac output	G3Q-SS2A	330	RTD	G3F-RD3A	800
	G3Q-SS4A	600	PID control	G3F-PIDA	300
Transistor output	G3Q-TR2A	120	Analog timer	G3F-AT3A	300
	G3Q-TR4A	200	Cnet link	G3L-CUEA	100
	G3Q-TR4B	200	Fnet I/F	G3L-FUEA	170
	G3Q-TR8A	300		G3L-FUOA	130
	G3Q-TR8B	300	Fnet remote I/F	G3L-RBEA	160
Interrupt input	G3F-INTA	200		G3L-RBOA	130

8.2 Specifications

8.2.1 K200S series

Item		GM6-PAFA	GM6-PAFB	GM6-PAFC	GM6-PDFA	GM6-PDFB
Input	Rated voltage	100 ~ 240 VAC			12 ~ 24 VDC	
	Rated frequency	50 ~ 60 Hz			-	
	Rated current	0.7 / 0.35 A (110 / 220 VAC)		0.8 / 0.4 A	1.5 / 0.7 A (12 / 24 VDC)	
	Inrush current	Max. 30 A		Max. 50 A	Max. 40 A	
	Efficiency	65% or more (with rated load)			65% or more (with rated load)	
	Fuse	3A/250VAC (slow blown type)		5A/250VAC	-	
	Dropout tolerance	20msec or less			1msec or less	
Output	Output voltage	5VDC / 24VDC	5VDC / ±15VDC	5VDC / 24VDC	5VDC	5VDC / ±15VDC
	Output current	5VDC : 2A 24VDC : 0.3A	5VDC : 2A +15VDC : 0.5A -15VDC : 0.2A	5VDC : 3.5A 24VDC : 0.3A	5VDC : 2A	5VDC : 3A +15VDC : 0.5A -15VDC : 0.2A
	Over current protection	5VDC : 2.2A 24VDC : 0.33A	5VDC : 2.2A +15VDC : 0.55A -15VDC : 0.22A	5VDC : 4.0A 24VDC : 0.33A	5VDC : 2.2A	5VDC : 3.3A +15VDC : 0.55A -15VDC : 0.22A
Indicator	LED (Turns on when output voltage is normal)					
Wire specification	0.75 ~ 2mm ²					
Weight1	320 g		400 g		400 g	

Caution

When a K200S system includes an A/D or D/A module, GM6-PAFB or GM6-PDFB module should be chosen for the power supply. Otherwise, A/D or D/A module can not operate due to lack of ±15VDC power supply.

8.2.2 K300S series

Item		GM4-PA1A	GM4-PA2A	GM4-PA1B	GM4-PA2A	GM4-PD3A
Input	Rated voltage	110VAC	220VAC	110VAC	220VAC	24VDC
	Rated frequency	50 ~ 60 Hz				-
	Rated current	1.3 A	0.8 A	0.65 A	0.35 A	1.2A
	Inrush current	Max. 40 A				Max. 100A
	Efficiency	65% or more (with rated load)				
	Fuse	3A/250VAC (slow blown type)				5A/250VAC
	Dropout tolerance	20msec or less				1msec or less
Output	Output voltage	5VDC / 24VDC				5VDC
	Output current	5VDC : 5A 24VDC : 0.7A		5VDC : 3A 24VDC : 0.5A		5VDC : 4A
	Over current protection	5VDC : 5.6A 24VDC : 0.8A		5VDC : 3.2A 24VDC : 0.6A		5VDC : 4.4A
Indicator	LED (Turns on when output voltage is normal)					
Wire specification	0.75 ~ 2mm ²					
Weight1	400 g					

8.2.3 K1000S series

Item		GM3-PA1A	GM3-PA2A	GM3-PD3A
Input	Rated voltage	110VAC	220VAC	24VDC
	Rated frequency	50 ~ 60 Hz		-
	Rated current	2.5 A	1.5 A	2.6 A
	Inrush current	Max. 40 A		Max. 100 A
	Efficiency	65% or more (with rated load)		60% or more
	Fuse	3A/250VAC (slow blown type)		8A / 250VAC
	Dropout tolerance	20msec or less		-
Output	Output voltage	5VDC / 24VDC		
	Output current	5VDC : 5A 24VDC : 1.5A	5VDC : 5A 24VDC : 1.5A	5VDC : 6A 24VDC : Bypass
	Over current protection	5VDC : 5.75A 24VDC : 1.6A	5VDC : 5.75A 24VDC : 1.6A	5VDC : 6.5A 24VDC : Bypass
Indicator	LED (Turns on when output voltage is normal)			
Wire specification	0.75 ~ 2mm ²			
Weight1	700 g			

8.3 Parts names and descriptions

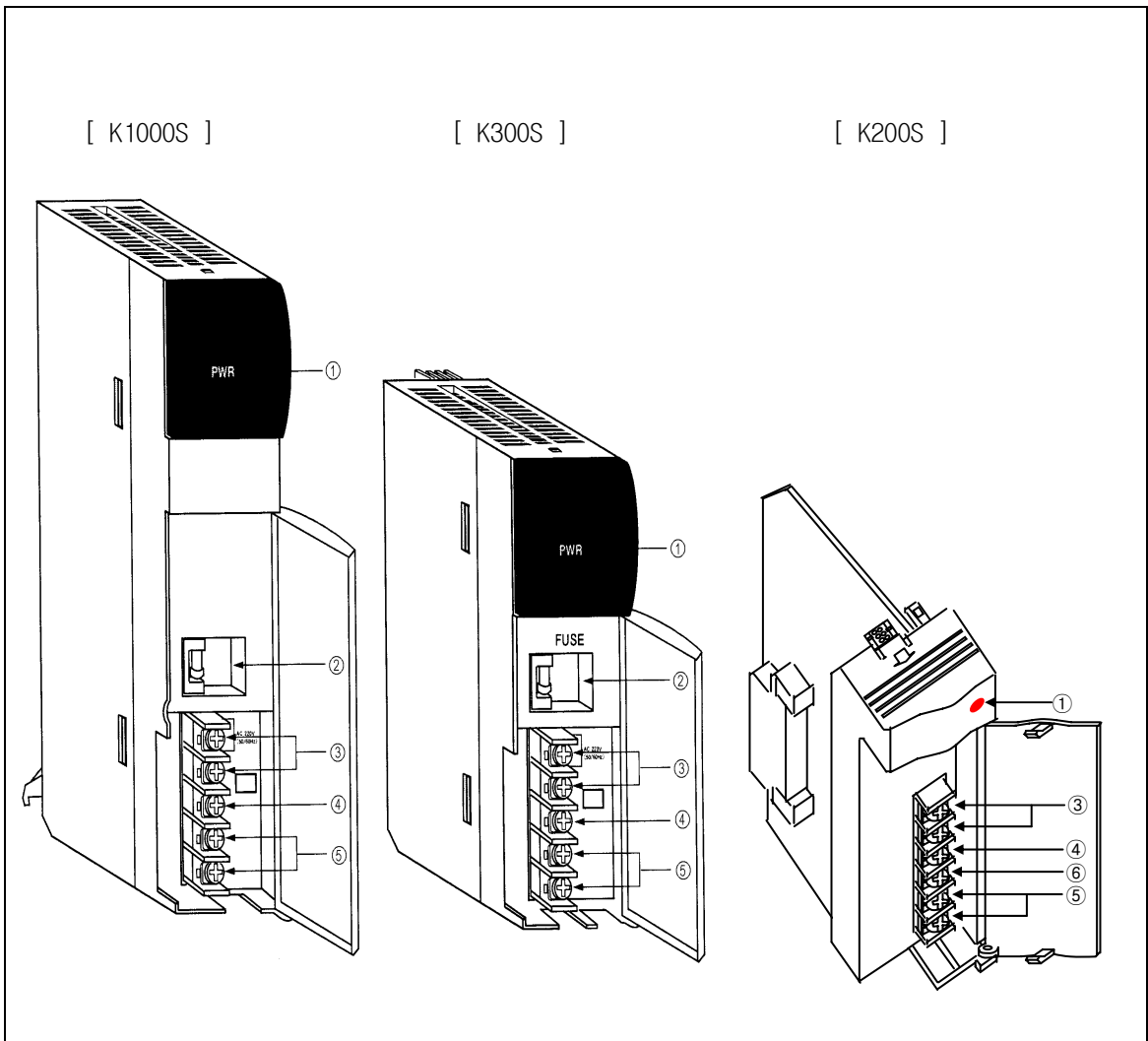

No	Name	Descriptions
1	Power LED	Indicates the status of 5VDC output
2	Fuse and fuse holder	Protection fuse and holder (K200S : mounted on the PCB)
3	Power input terminal	Connect incoming power source (AC or DC power)
4	LG terminal	Line ground
5	24VDC, 24VG terminals	24VDC service power for output modules (relay, TR)
6	FG terminal	Frame ground

Chapter 9 Base boards and cables

9 Base boards and cables	9-1
9.1 Specifications.....	9-1
9.1.1 Main base	9-1
9.1.2 Expansion base	9-2
9.1.3 Expansion cable.....	9-2
9.2 Parts names and descriptions.....	9-3
9.2.1 Main base	9-3
9.2.2 Expansion base	9-5

9 Base boards and cables

9.1 Specifications

9.1.1 Main base

1) K200S series

Type Item	GM6-B04M	GM6-B06M	GM6-B08M	GM6-B12M
No. of slots	4 slots	6 slots	8 slots	12 slots
Dimension	244 × 110 × 62	314 × 110 × 62	384 × 110 × 62	524 × 110 × 62
Mounting hole	φ 4.5 (M4 screw)			
Screw for FG	BHM 3 × 6 washer			
Weight	240 g	350 g	750 g	1000 g

2) K300S series

Type Item	GM4-B04M	GM4-B06M	GM4-B08M	GM4-B12M ¹
No. of slots	4 slots	6 slots	8 slots	12 slots
Dimension (mm)	297 × 135 × 17	367 × 135 × 17	437 × 135 × 17	540 × 135 × 17
Mounting hole	φ 4.5 (M4 screw)			
Screw for FG	BHM 3 × 6 washer			
Weight	850 g	1,100 g	1400 g	1850 g

3) K1000S series

Type Item	GM3-B04M	GM3-B06M	GM3-B08M
No. of slots	4 slots	6 slots	8 slots
Dimension (mm)	297 × 250 × 17	367 × 250 × 17	437 × 250 × 17
Mounting hole	φ 4.5 (M4 screw)		
Screw for FG	BHM 3 × 6 washer		
Weight	1,700 g	2,100 g	2,500 g

¹ The GM4-B12M can not be connected with expansion base.

9.1.2 Expansion base

1) K300S series

Type Item	GM4-B04E	GM4-B06E	GM4-B08E
No. of slots	4 slots	6 slots	8 slots
Dimension (mm)	297 × 135 × 17	367 × 135 × 17	437 × 135 × 17
Mounting hole	φ 4.5 (M4 screw)		
Screw for FG	BHM 3 × 6 washer		
Weight	900 g	1,150 g	1,400 g

2) K1000S series

Type Item	GM3-B04E	GM3-B06E	GM3-B08E
No. of slots	4 slots	6 slots	8 slots
Dimension (mm)	297 × 250 × 17	367 × 250 × 17	437 × 250 × 17
Mounting hole	φ 4.5 (M4 screw)		
Screw for FG	BHM 3 × 6 washer		
Weight	1,700 g	2,100 g	2,500 g

9.1.3 Expansion cable

1) K300S series

Type Item	G4C-E041	G4C-E121	G4C-E301
Length	0.4 m	1.2 m	3.0 m
Weight	210 g	520 g	1,090 g

2) K1000S series

Type Item	G3C-E061	G3C-E121	G3C-E301
Length	0.6 m	1.2 m	3.0 m
Weight	370 g	520 g	1,270 g

9.2 Parts names and descriptions

9.2.1 Main base

1) K200S

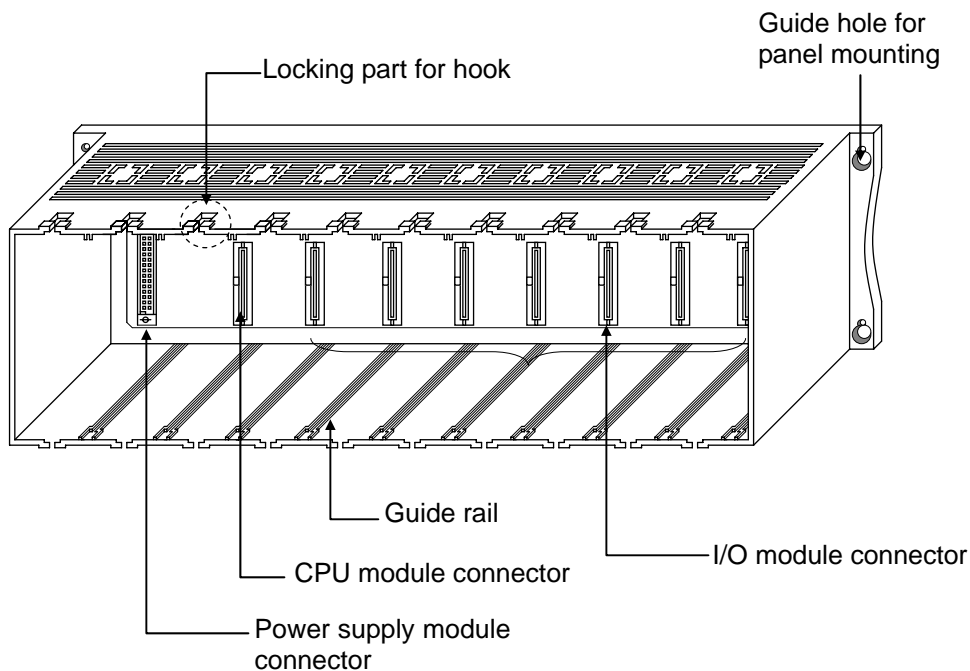

2) K300S

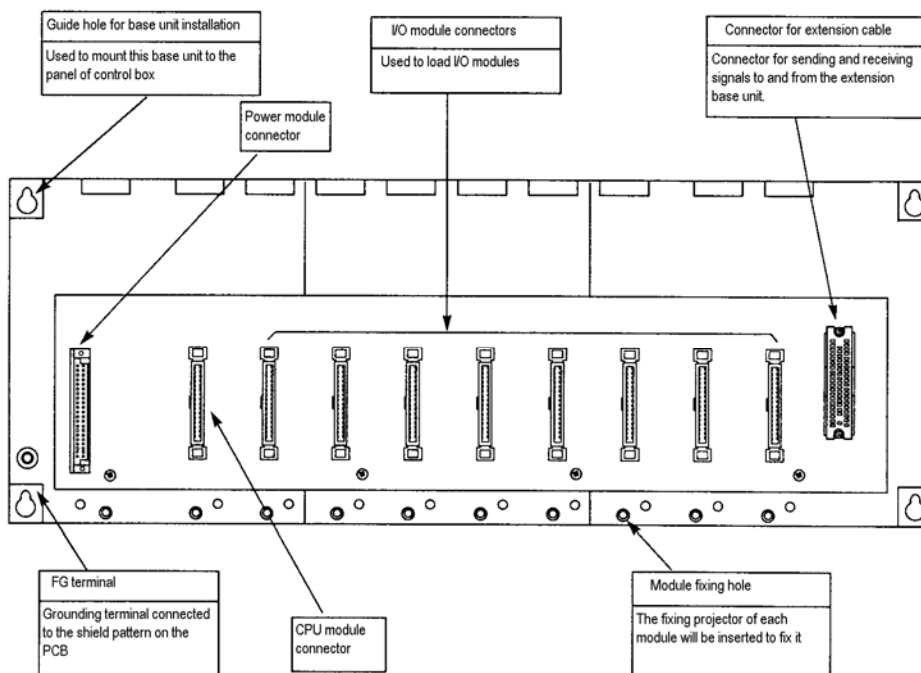

3) K1000S

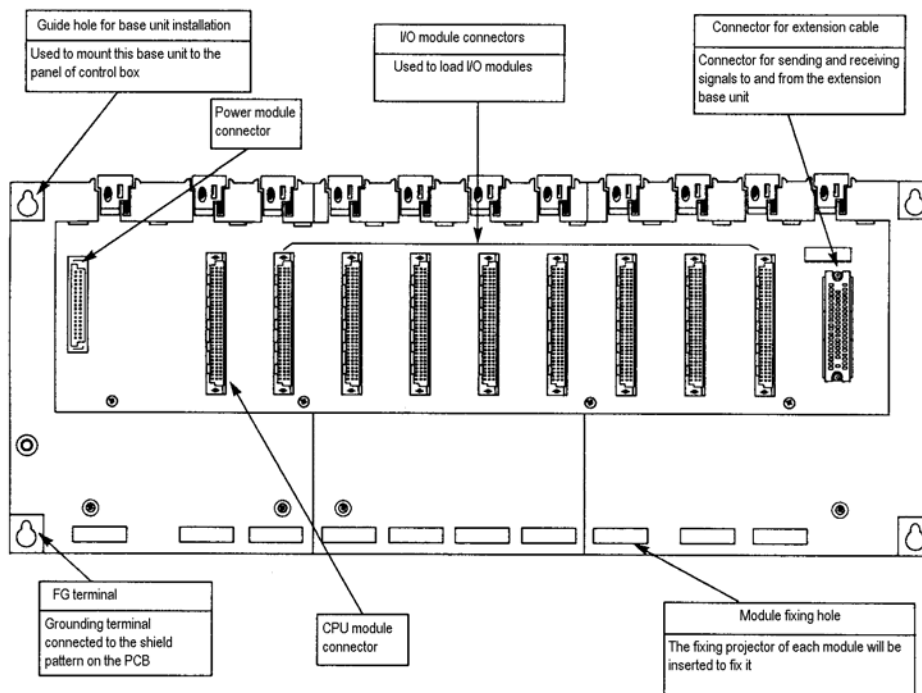

9.2.2 Expansion base

1) K300S

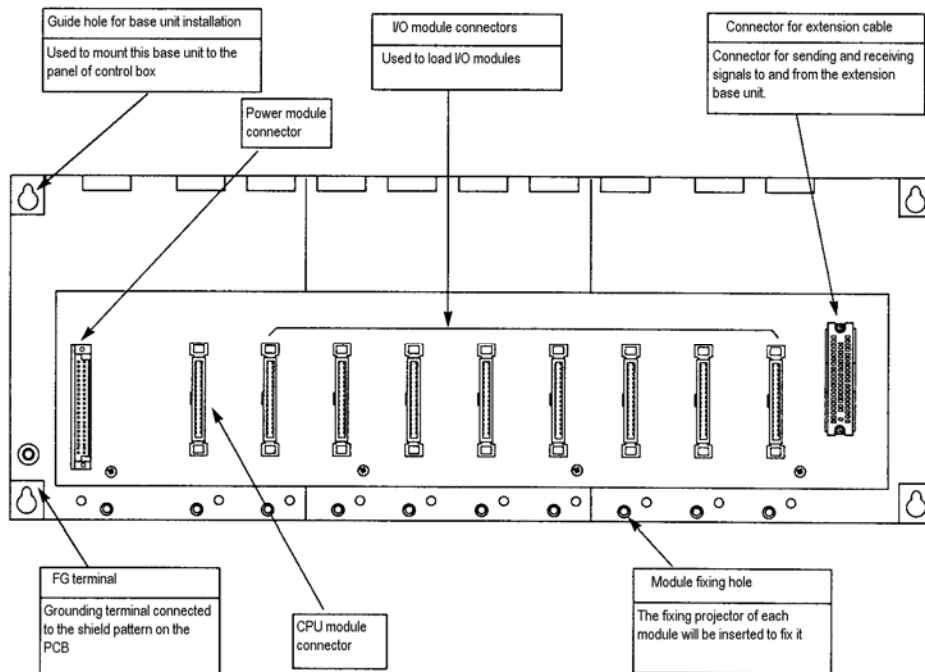

2) K1000S

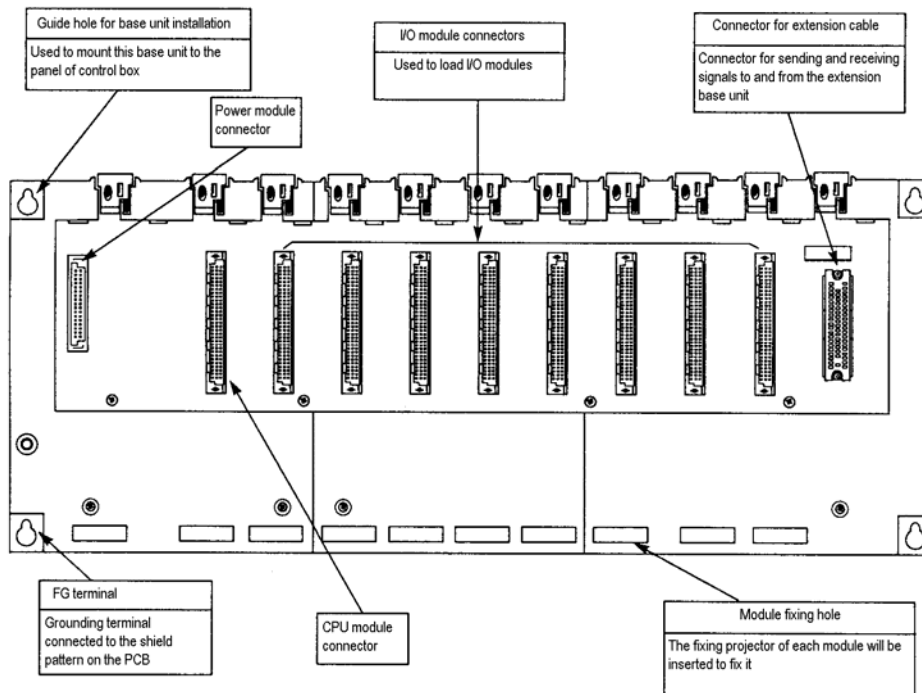

Chapter 10 Installation and wiring

10	Installation and wiring	10-1
10.1	Installation	10-1
10.1.1	Installation environment	10-1
10.1.2	Precaution during installation	10-1
10.1.3	Heat protection design of control box	10-1
10.1.4	Calculation of the capacity of power supply	10-2
10.1.5	Handling Instructions	10-4
10.2	Mounting / dismantling of module	10-7
10.2.1	Mounting a module on a base	10-7
10.2.2	Dismounting a module from base board	10-10
10.3	Wiring	10-13
10.3.1	Power Supply Wiring	10-13
10.3.2	Input and Output Devices Wiring	10-15
10.3.3	Grounding	10-15
10.3.4	Cable Specifications for wiring	10-16

10 Installation and wiring

10.1 Installation

10.1.1 Installation environment

The MASTER-K series is designed to have good reliability and durability in any installation environment. However, please avoid installing the PLC at the following locations to assurance the reliability and durability of PLC system.

- 1) Where temperature may experience ambient drops or rising over 0 ~ 55°C (32 ~ 131°F)
- 2) Where condensation may occur due to abrupt temperature changes
- 3) Where vibration and shock are directly transmitted to the PLC
- 4) Where the PLC is exposed to the direct rays of the sun
- 5) Where the PLC is exposed to corrosive or inflammable gas
- 6) Where the PLC is exposed to conductive powder

10.1.2 Precaution during installation

- 1) During drilling or wiring, do not allow any wire scraps to enter into the PLC.
- 2) Install the PLC on locations that are convenient for operation.
- 3) Make sure that it is not located on the same panel that high voltage equipment located..
- 4) Make sure that the distance from walls of duct and external device be 50 mm or more.
- 5) Be sure to be grounded to locations that have good ambient noise immunity.

10.1.3 Heat protection design of control box

- 1) When installing the PLC in a closed control box, be sure to design heat protection of control box with consideration of the heat generated by the PLC itself and other devices.
- 2) It is recommended that filters or closed heat exchangers be used.

10.1.4 Calculation of the capacity of power supply

The following shows the procedure for calculating the PLC system power consumption.

- 1) PLC system power consumption block diagram

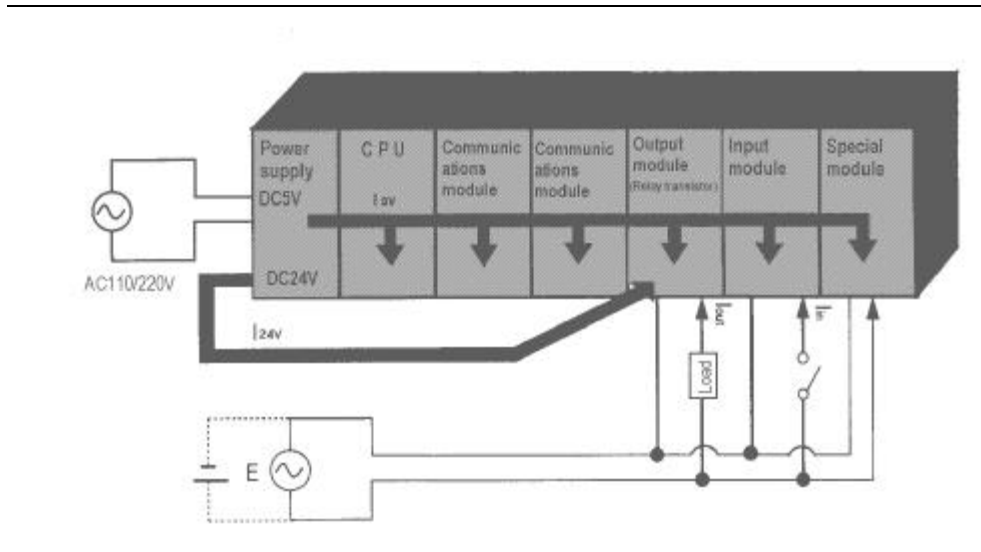

- 2) Power consumption of each part

Power consumption of a power supply module

Approximately 70% of the power supply module current is converted into power and 30% of that 70% dissipated as heat, i.e., 3/7 of the output power is actually used.

- $W_{pw} = 3/7 \{ (I_{5V} \times 5) + (I_{24V} \times 24) \}$ (W)

where, $I_{5V} = 5$ VDC circuit current consumption of each module

$I_{24V} = 24$ VDC circuit average current consumption of output modules (with points simultaneously switched ON). Not for 24 VDC power supplied from external or power supply modules that has no 24 VDC output.

Total 5 VDC power consumption

The total power consumption of all modules is the power of the 5 VDC output circuit of the power supply module.

- $W_{5V} = I_{5V} \times 5$ (W)

Average 24 VDC power consumption (with points simultaneously switched ON)

The total power consumption of all modules is the average power of the 24 VDC output circuit of the power supply module.

- $W_{24V} = I_{24V} \times 24$ (W)

Average power consumption by voltage drop of output modules (with points simultaneously switched ON)

- $W_{out} = I_{out} \times V_{drop} \times \text{output points} \times \text{the rate of points switched on simultaneously (W)}$

I_{out} : output current (actual operating current) (A)
 V_{drop} : voltage dropped across each output load (V)

Average power consumption of input circuits if input modules (with points simultaneously switched ON)

- $W_{in} = I_{in} \times E \times \text{input points} \times \text{the rate of points switched on simultaneously (W)}$

I_{in} : input current (effective value for AC) (A)
 E : input voltage (actual operating voltage) (V)

Power consumption of the special module power supply

- $W_s = I_{5V} \times 5 + I_{24V} \times 24 + I_{100V} \times 100 \text{ (W)}$

The sum of the above values is the power consumption of the entire PLC system.

- $W = W_{PW} + W_{5V} + W_{24V} + W_{OUT} + W_{IN} + W_s \text{ (W)}$

Check the temperature rise within the control panel with calculation of that total power consumption(W).

The temperature rise in the control panel is expressed as:

$$T = W/UA [^{\circ}\text{C}]$$

W : Power consumption of the entire PLC system (obtained as shown above)

A : Control panel inside surface area (m²)

U : 6 (if the control panel temperature is controlled by a fan, etc.)

4 (if control panel air is not circulated)

10.1.5 Handling Instructions

to installing the temperature-measuring resistor input module, be sure to check the following:

- Do not drop it off, and make sure that strong shock should not be applied.
- Do not unload the PCB from its case. It can cause faults.
- During wiring, be sure to check any foreign matter like wire scraps should not enter into the upper side of the PLC. If any foreign matter has entered into it, always eliminate it.
- Do not load or unload the module while the power supply is being connected.

1) I/O module handling instructions

The followings explains instructions for handling or installing the input module.

I/O module specifications re-check

Re-check the input voltage for the input module. If a voltage over the maximum switching capacity is applied, it can cause faults, destruction or fire.

Wire selection

Select the wire with due consideration of ambient temperature and rated current. Its minimum specifications should be AWG22(0.3 mm²) or more.

Environment

When wiring the I/O module, if it locates near a device generating an cause short circuit, destruction or malfunction.

Polarity

Before applying the power to a module that has polarities, be sure to check its polarities.

Wiring

- Wiring I/O wires with high voltage cable or power supply line can cause malfunction or disorder.
- Be sure that any wire does not pass across during input LED (I/O status will not be clearly identified).
- If an inductive load has been connected to output module, connect parallel surge killer or diode to a load. Connect the cathode part of diode to the + part of the power supply.

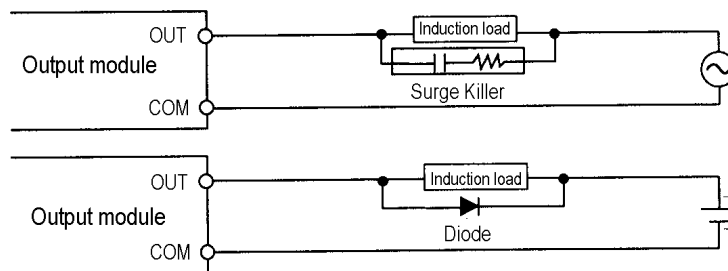

Terminal block

Check its fixing. During drilling or wiring, do not allow any wire scraps to enter into the PLC. It can cause malfunction and fault.

Be cautious that strong shock does not applied to the I/O module. Do not separate the PCB from its case.

2) 2) Base board mounting instructions

The following explains instructions for mounting the PLC onto the control panel.

Allow sufficient distance from the upper part of the module for easy module replacement.

Do not mount the PLC in a vertical or horizontal position because it affects on ventilation.

Do not mount the base board together with a large-sized electromagnetic contactor or no-fuse breaker, which produces vibration, on the same panel. Mount them on different panels, or keep the base board away from such a vibration source.

Mount the wire duct as it is needed.

If the clearances are less than those in Fig 10.1, follow the instructions shown below.

- If the wire duct is mounted on the upper part of the PLC, make the wiring duct clearance 50mm or less for good ventilation. Also, allow the distance enough to press the hook in the upper part from the upper part of the PLC.
- If the wire duct is mounted on the lower part of the PLC, make optic or coaxial cables contact it and consider the minimum diameter of the cable.

To protect the PLC from radiating noise or heat, allow 100 mm or more clearances between it and parts. Left or right clearance and clearance from other device in the left or right side should be 50 mm or more.

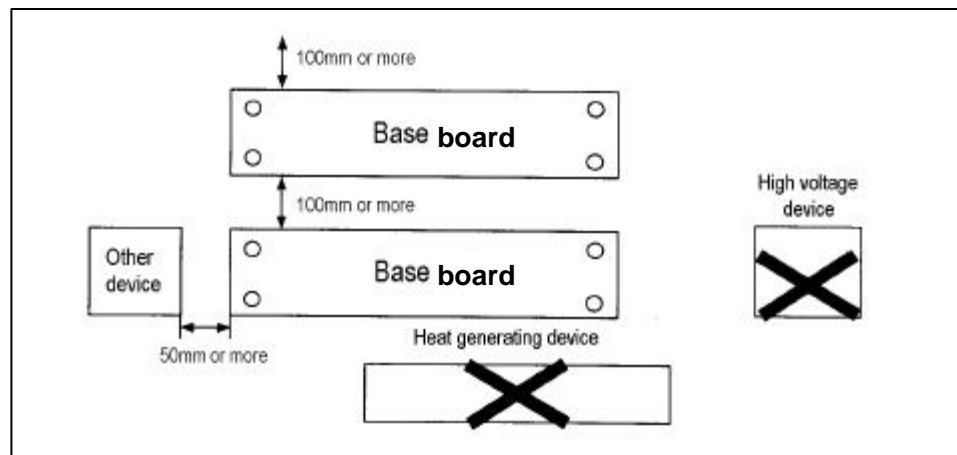

[Fig. 10.1] PLC mounting

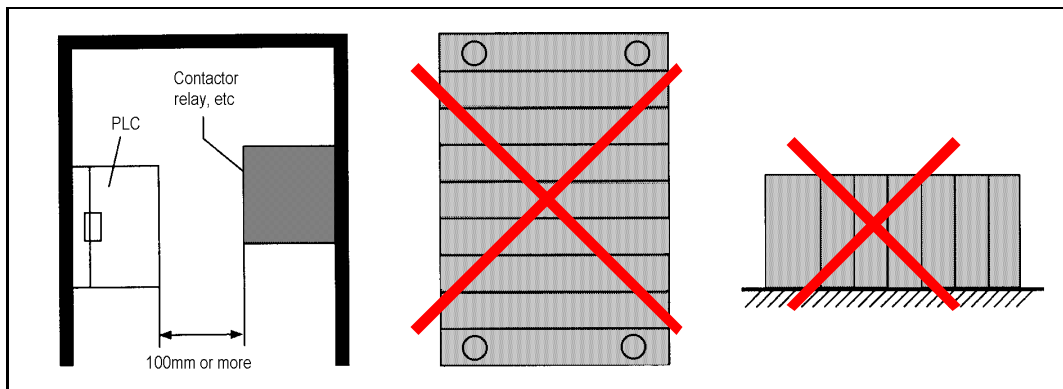

[Fig.10.2] Clearance from the front device [Fig. 10.3] Vertical mounting [Fig 10.4] Horizontal mounting

10.2 Mounting / dismounting of module

10.2.1 Mounting a module on a base

1) K200S

- Insert a module to an empty slot along the guide rail until the hook is locked with the base board.
- Check that the module is firmly locked into the base board.

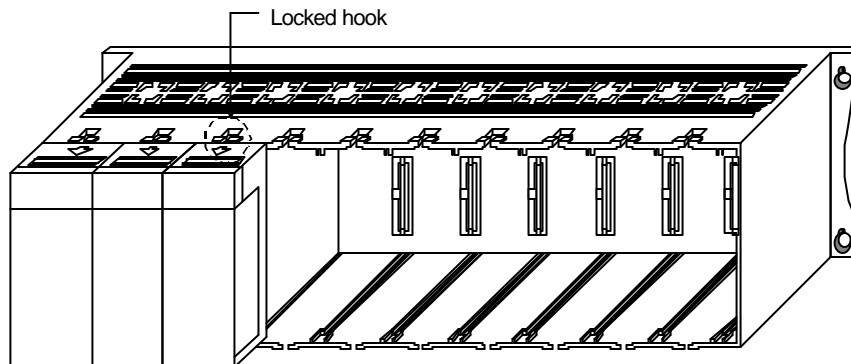
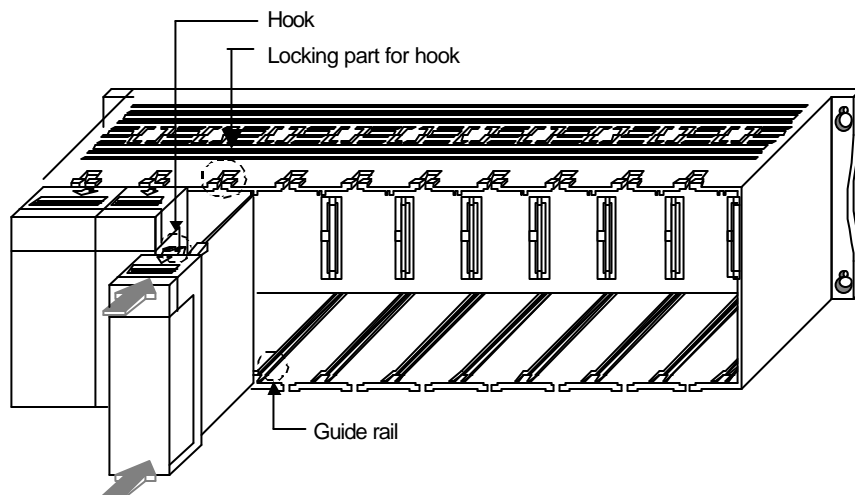

Remark

The CPU module should be mounted the next slot of the slot for power supply module. If the CPU module is inserted on other slots and the GM6-PAFB or GM6-PDFB is used, the CPU module is damaged by the $\pm 15\text{VDC}$ supplied from the power module.

2) K300S

- Insert the module fixing projections in the upper part into the module fixing hole in the base board.
- Install the module onto the base board by pushing the bottom forward and fix it onto the base board with module fixing screws.
- Check that the module is firmly mounted onto the base board by pulling the upper part of the module.

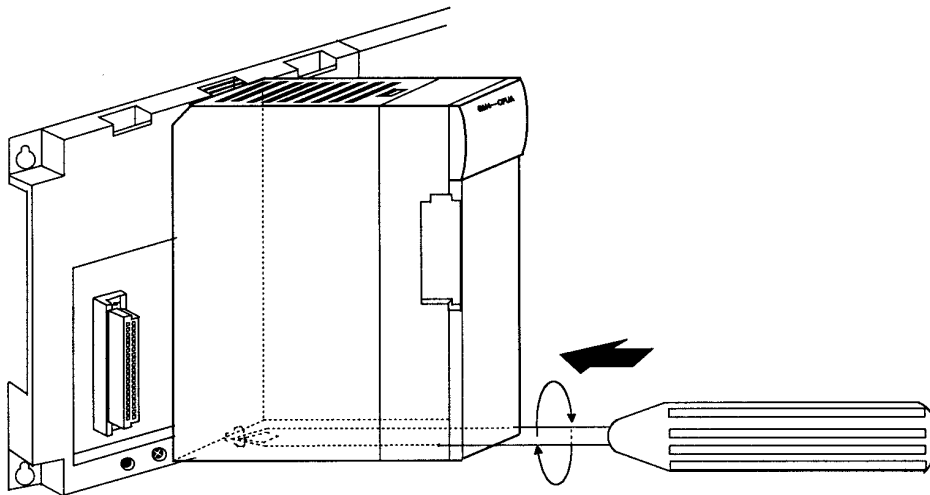
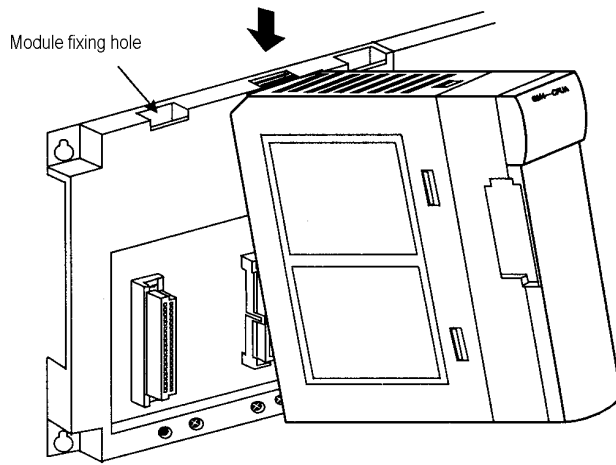

3) K1000S

- Insert the module fixing projections in the lower part into the module fixing hole in the base board.
- Install the module onto the base board by pushing the top forward.
- Check that the module is firmly mounted onto the base board by pulling the upper part of the module.

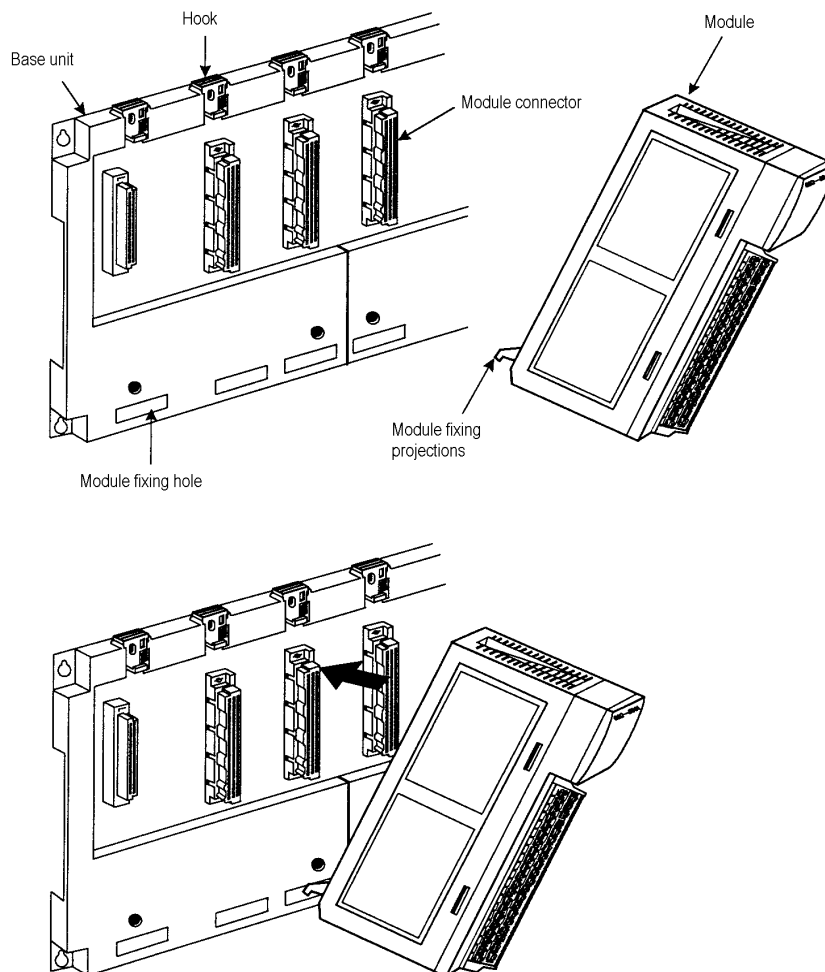
**Remark**

When the PLC system is located at the place with a serious vibration and shocks, fix a module to a base board more surely by fastening a screw.

10.2.2 Dismounting a module from base board

1) K200S

- Press the locking hook and pull a module as following figure.

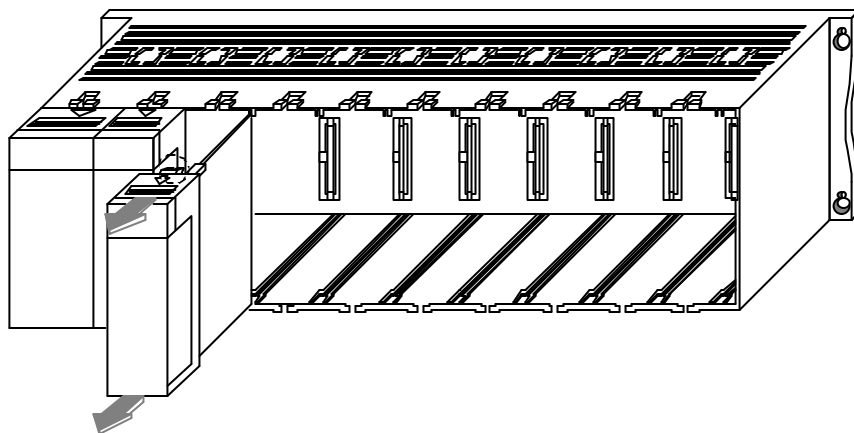
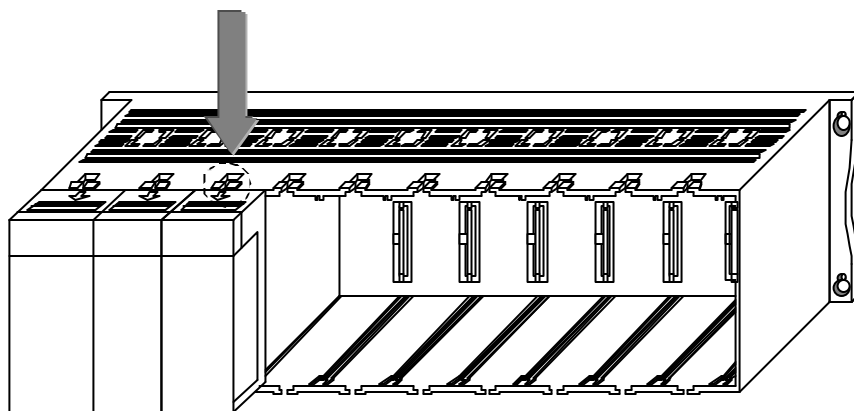

2) K300S

- First, release the module fixing screws in the bottom from the base board.
- While pushing the hook latch, pull the upper part of the module toward you.
- While lifting the module upwards and remove the module hook from the module fixing hole.

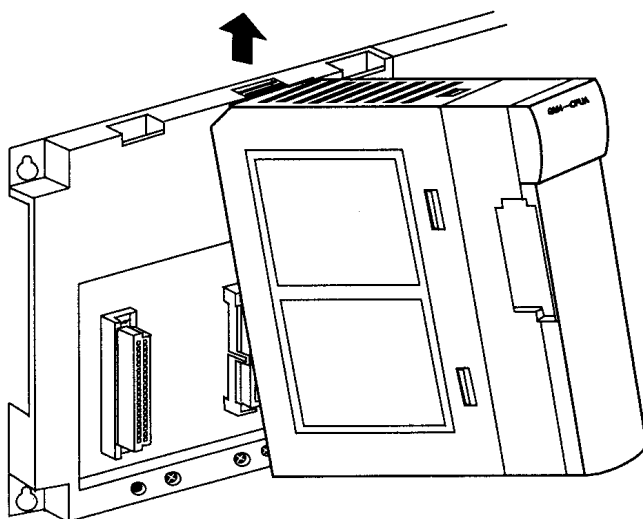
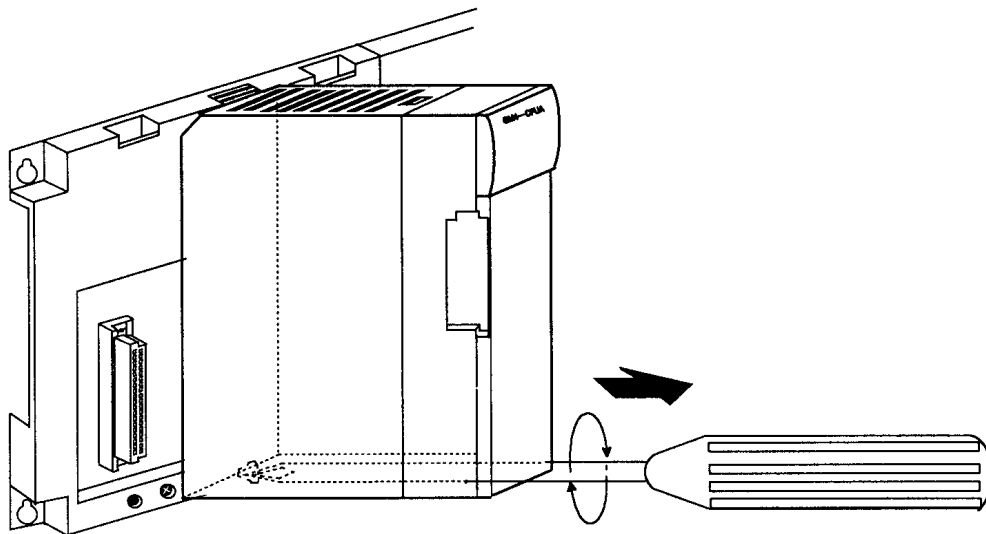

3) K1000S

- First, push the hook latch fully.
- While pushing the hook latch, pull the upper part of the module toward you.
- Lift upwards and remove the module hook from the module fixing hole.

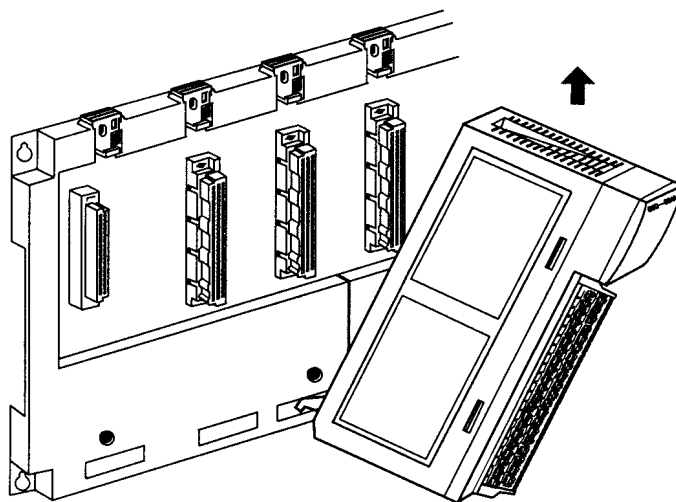
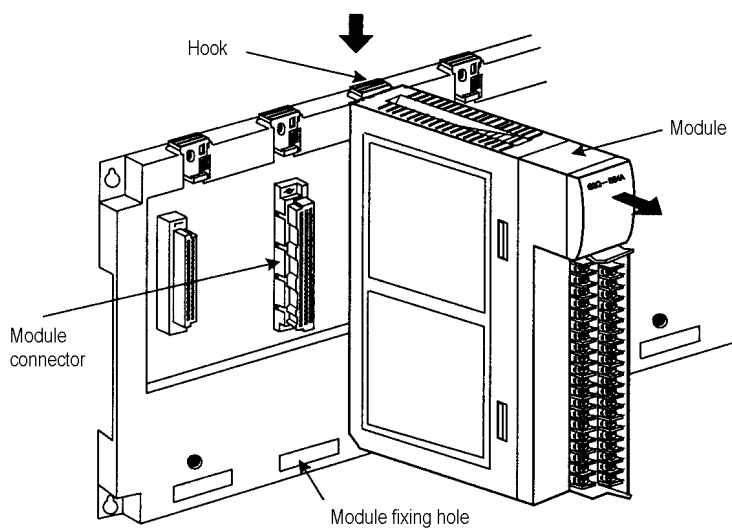

10.3 Wiring

The followings explains the wiring instructions for use of the system.

10.3.1 Power Supply Wiring

- 1) When voltage fluctuations are larger than the specified value, connect a constant-voltage transformer.
- 2) Use a power supply which generates minimal noise across wire and across PLC and ground. (When excessive noise is generated, connect an insulating transformer)
- 3) When wiring, separate the PLC power supply from the I/O and power device as shown below.

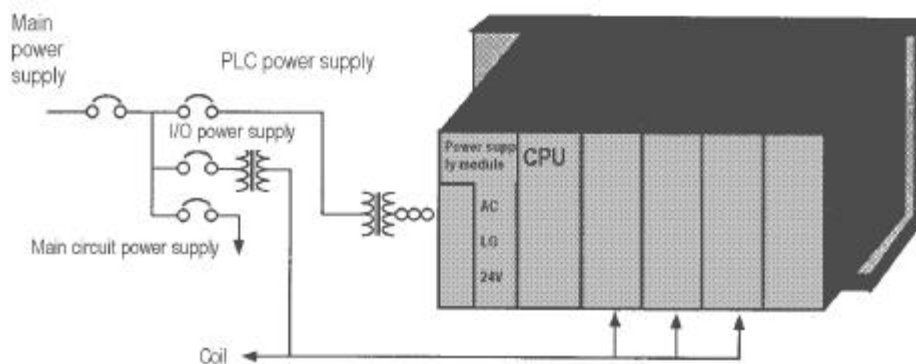
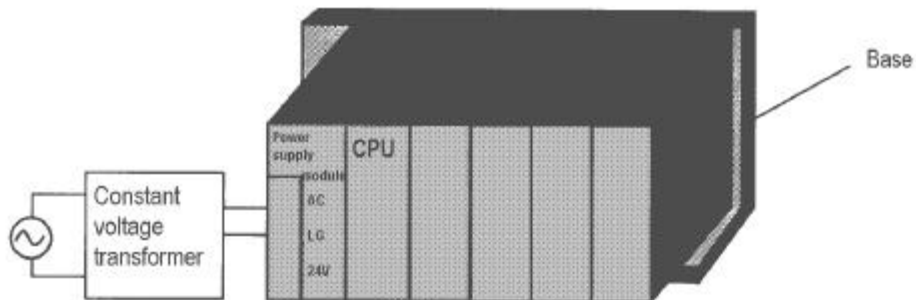

- 4) Notes on using 24 VDC output of the power supply module
- To protect the power supply modules, do not supply one I/O module with 24 VDDC from several power supply modules connected in parallel.
 - If 24 VDC output capacity is sufficient for one power supply module, supply 24 VDC from the external 24 VDC power supply as shown below.

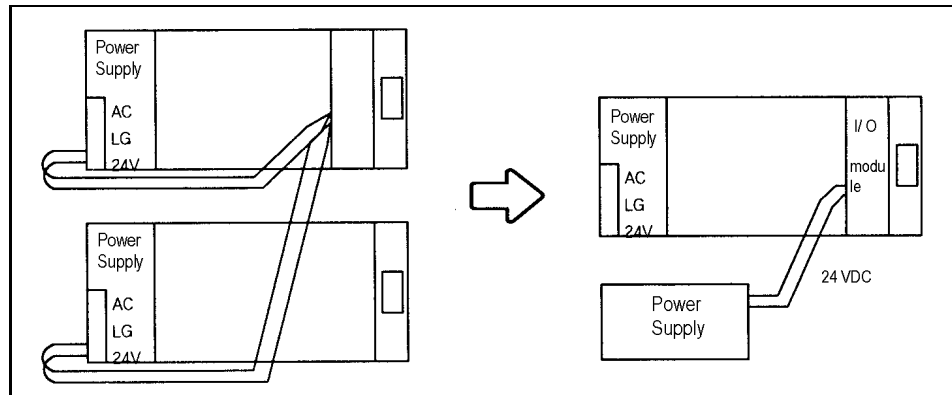

- 5) Twist the 110 VAC, 220 VAC, and 24 VDC cables as closely as possible. Connect modules with the shortest possible wire lengths.
- 6) To minimize voltage drop, use the thickest (max. 2 mm²) wires possible for the 100 VAC, 200VAC and 24 VDC cables.
- 7) Do not bundles the 100 VAC and 24 VDC cables with main-circuit(high voltage, large current) wires or the I/O signal wires. If possible, provide more than 100 mm distance between the cables and wires.
- 8) As a lightning-protection measure, connect a surge absorber as shown below.

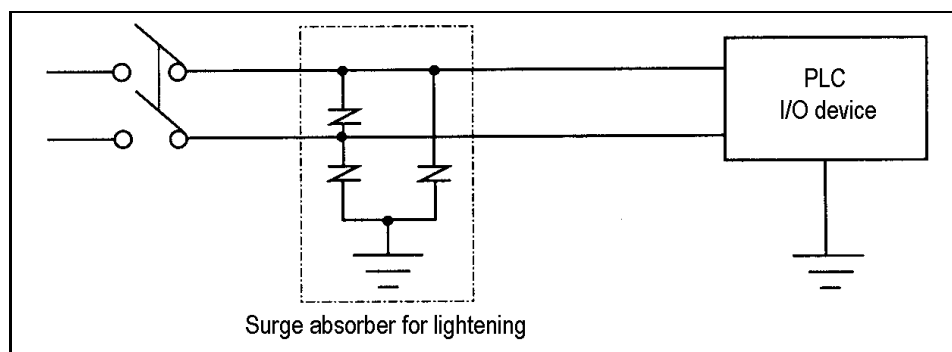

- 9) Use a insulating transformer or noise filter for protection against noise .
- 10) Twist every input power supply wires as closely as possible. Do not allow the transformer or noise filter across the duct.

10.3.2 Input and Output Devices Wiring

- 1) Applicable size of wire for I/O wiring is 0.3 to 2 mm^2 . However, it is recommended to use wire of 0.3 mm^2 for convenience.
- 2) Separate the input and output lines.
- 3) I/O signal wires must be at least 100 mm away from high voltage and large current main circuit wires.
- 4) When the I/O signal wires cannot be separated from the main circuit wires and power wires, ground on the PLC side with batch-shielded cables.

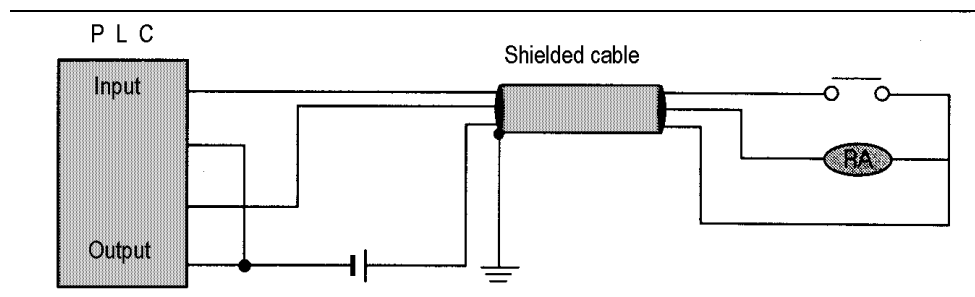

- 5) If wiring has been done with a piping, ground the piping.
- 6) Separate the 24 VDC I/O cables from the 110 VAC and 220 VAC cables.
- 7) If wiring over 200 m or longer distance, problems can be caused by leakage currents due to line capacity. Refer to the Section 12.4 Examples.

10.3.3 Grounding

- 1) This PLC has sufficient protection against noise, so it can be used without grounding except for special much noise. However, when grounding it should be done conforming to below items.
- 2) Ground the PLC as independently as possible. Class 3 grounding should be used (grounding resistance 100Ω or less).
- 3) When independent grounding is impossible, use the joint grounding method as shown in the figure below (B).

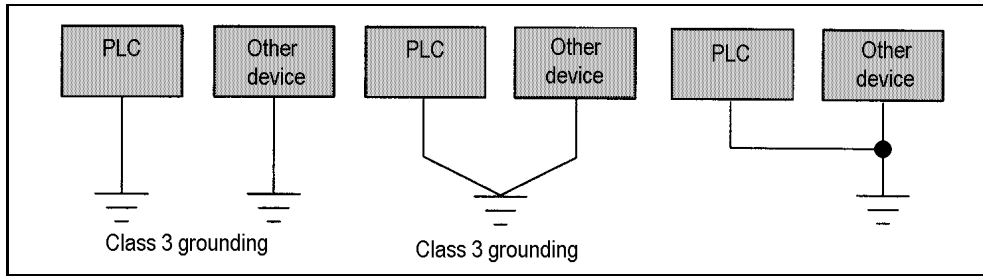

(A) Independent grounding : Best (B) Joint grounding : Good (C) Joint grounding : Not allowed

- 4) Use 2 mm² or more wire for grounding line. Make the distance as short as possible with the grounding point located to nearest to the PLC.
- 5) Ground LG (Power Supply Module) separately with FG (Base board).

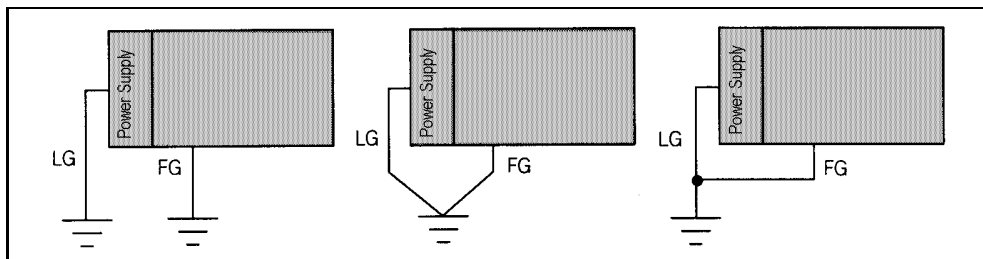

(A) Independent grounding : BEST (B) Joint grounding : GOOD (C) Joint Grounding : Not Allowed

- 6) If a malfunction occurs depend on grounding point, separate FG (Base Board) with ground.

10.3.4 Cable Specifications for wiring

Kinds of external connection	Cable Specifications (mm ²)	
	Minimum	Maximum
Digital Input	0.18 (AWG 24)	1.5 (AWG16)
Digital Output	0.18 (AWG24)	2.0 (AWG14)
Analog Input/Output	0.18 (AWG24)	1.5 (AWG16)
Communication	0.18 (AWG24)	1.5 (AWG16)
Main Power	1.5 (AWG16)	2.5 (AWG12)
Grounding	1.5 (AWG16)	2.5 (AWG12)

Chapter 11 Maintenance

11	Maintenance	11-1
11.1	Maintenance and inspection	11-1
11.2	Daily inspection	11-2
11.3	Periodic inspection.....	11-3

11 Maintenance

Be sure to perform daily and periodic maintenance and inspection in order to keep the PLC system in the best conditions.

11.1 Maintenance and inspection

The most of parts of PLC modules are consist of semiconductor devices, and their service life is semi-permanent. However, a bad environment can shorten the lifetime of parts or cause a defection of PLC system. Therefore, check the followings items one or two times in a six months.

Items		Judgment criteria	Corrective action
Environment	Temperature	0 ~ 55°C (32 ~ 131°F)	Adjust the temperature or / and humidity as not exceed the operation temperature / humidity range.
	Humidity	5 ~ 95 % RH	
	Vibration	No vibration	Use a insulation resist rubber or other prevention methods
Mounting condition of modules		No loose modules	Mount a module firmly on base
Terminal block screw		No loose screws	Fasten a screw firmly with rated torque
Power voltage ripple		-15 % ~ +10%	Adjust the power voltage
Spare parts		No lack of spare parts	Supplement spare parts

11.2 Daily inspection

Perform daily inspections everyday as following table;

Check Items	Check points	Judgment	Corrective Actions
Base unit mounting conditions	Check for loose mounting screws	The base unit should be securely mounted	Retighten Screws
Mounting conditions of I/O modules	<ul style="list-style-type: none"> • Check if the hook is securely engaged • Check if the upper cover is securely mounted 	The hook should be securely engaged	Securely engage the hook
Connecting conditions of terminal block or extension cable	Check for loose terminal screws	Screws should not be loose	Retighten terminal screws
	Check the distance between solderless terminals	Proper clearance should be provided	Correct
	Check connectors of extension cable	Connectors should not be loose	Correct
Indicating LED	Power LED Check that the LED is ON	ON(OFF indicates an error)	Refer chapter 12
	Run LED Check that the LED is ON during Run	ON(ON or flickering indicates an error)	
	Stop LED Check that the LED is OFF during Run	OFF(ON indicates an error)	
	Input LED Check that the LED turns ON and OFF	ON when input is ON, OFF when input is off	
	Output LED Check that the LED turns ON and OFF	ON when output is ON. OFF when output is OFF	

11.3 Periodic inspection

Check the following items once or twice every six months, and perform the needed corrective actions.

Check Items		Checking Methods	Judgment	Corrective Actions
Ambient environment	temperature	Measure with thermometer and hygrometer Measure corrosive gas	0 to 55°C	
	Ambient humidity		5 to 95% RH	
	Ambiance		There should be no corrosive gases	
PLC conditions	Looseness, play	Move the unit	The module should be mounted securely	Retighten screws
	Ingress of dust or foreign material	Visual check	No dust or foreign material	
Connecting conditions	Loose terminal screws	Retighten	Screws should not be loose	Retighten
	Distance between solderless terminals	Visual check	Proper clearance	Correct
	Loose connector	Visual check	Connectors should not be loose	Retighten connector mounting screws
Line voltage check		Measure voltage across 110/ 220 VAC terminal	85 to 132VAC 170 to 264VAC	Change supply power
Battery		Check battery replacement time and battery capacity reduction	<ul style="list-style-type: none"> • Check total power failure time and the specified source life • Battery capacity reduction should not be indicated 	If battery capacity reduction is not indicated, Change the battery when specified service life is exceeded
Fuse		Visual check	No melting disconnection	If fuse melting disconnection, change the fuse periodically because a surge current can cause heat

Chapter 12 Troubleshooting

12 Troubleshooting	12-1
12.1 Basic procedure for troubleshooting	12-1
12.2 Troubleshooting	12-2
12.2.1 The power LED is turned off.....	12-2
12.2.2 The STOP LED is flickering	12-3
12.2.3 RUN and STOP LED are off.....	12-4
12.2.4 The load of the output module is not operating.....	12-5
12.2.5 Program download is unable.....	12-6
12.3 Troubleshooting questionnaire	12-7
12.4 Troubleshooting examples	12-8
12.4.1 Input circuit troubles and corrective actions	12-8
12.4.2 Output circuit troubles and corrective actions.....	12-9
12.5 Error code list	12-11

12 Troubleshooting

This chapter explains the types of conditions that might cause an error to be reported and gives suggestions on how to resolve the problem.

12.1 Basic procedure for troubleshooting

The reliability of PLC system not only depends on reliable equipment but also on fast and suitable corrective actions when an error occurs.

To resolve a problem of PLC system quickly, it is most important to find the cause of the problem. The followings describe how to find the cause of problem.

1) Visual checks

Operation status of system (stop or running)

Power supplying status (on or off)

The status of I/O module

The external wiring (I/O, expansion and communication cables)

The contents of error flags (check by connecting handy loader or KGL-WIN after above items are completed)

2) Cycling the power of PLC

See what happens on the PLC system when the key switch is moved to the STOP mode and cycle the power of CPU module.

3) Narrow down the cause of problem.

From the result of above procedures, deduce where the cause of problem lies on, i.e;

Inside of PLC or outside

I/O module or other module

Sequence program

12.2 Troubleshooting

12.2.1 The power LED is turned off

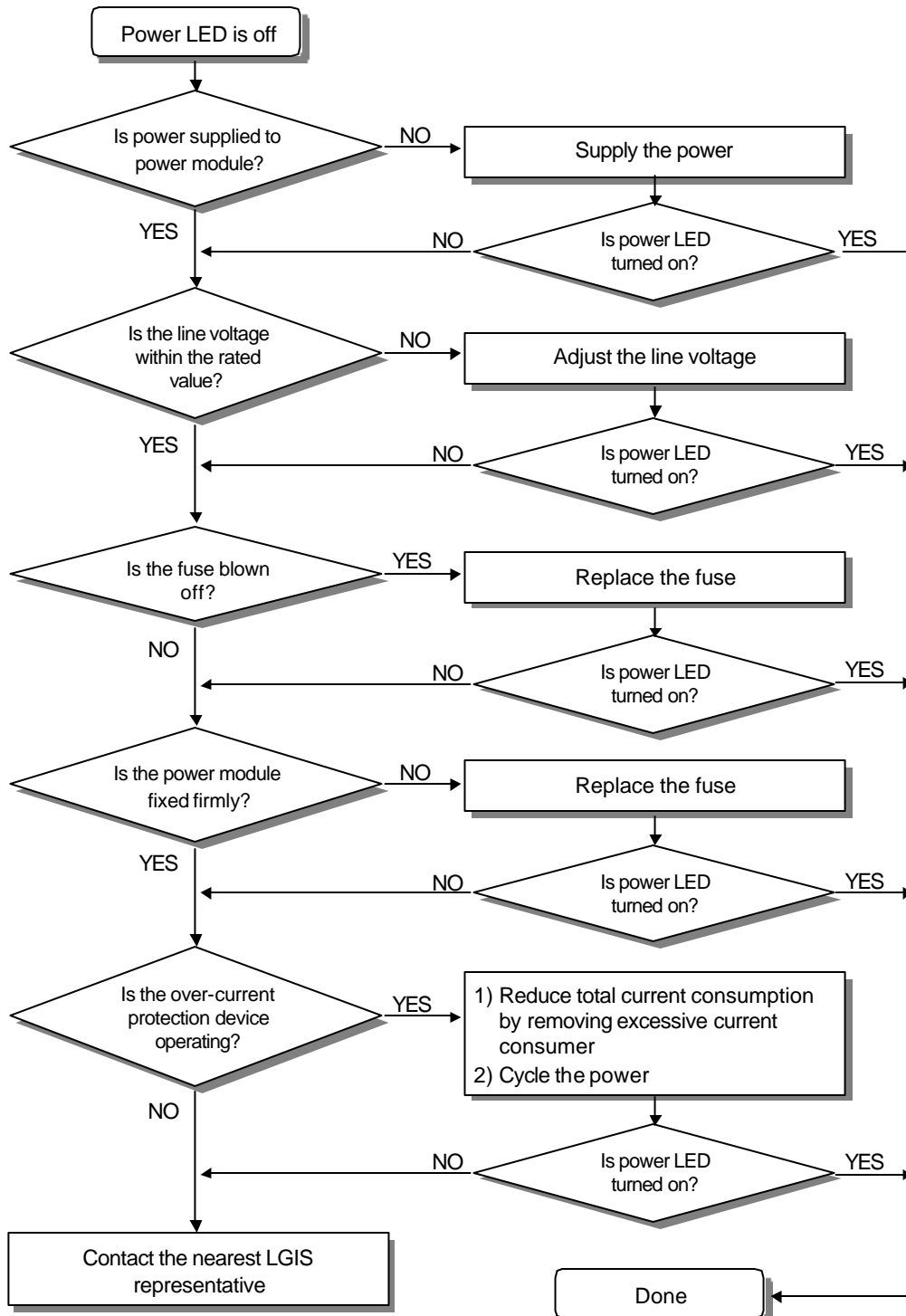

12.2.2 The STOP LED is flickering

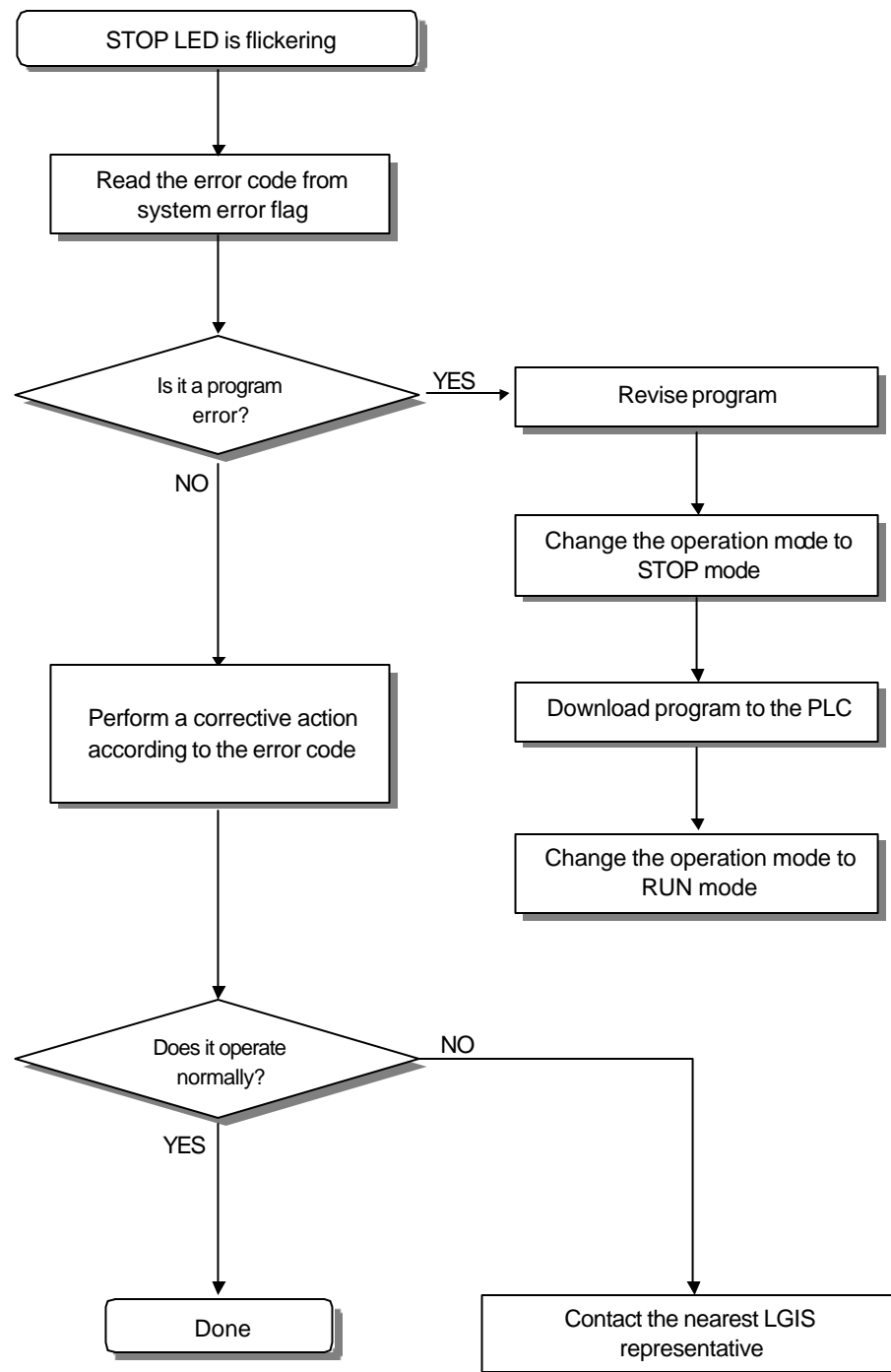

12.2.3 RUN and STOP LED are off

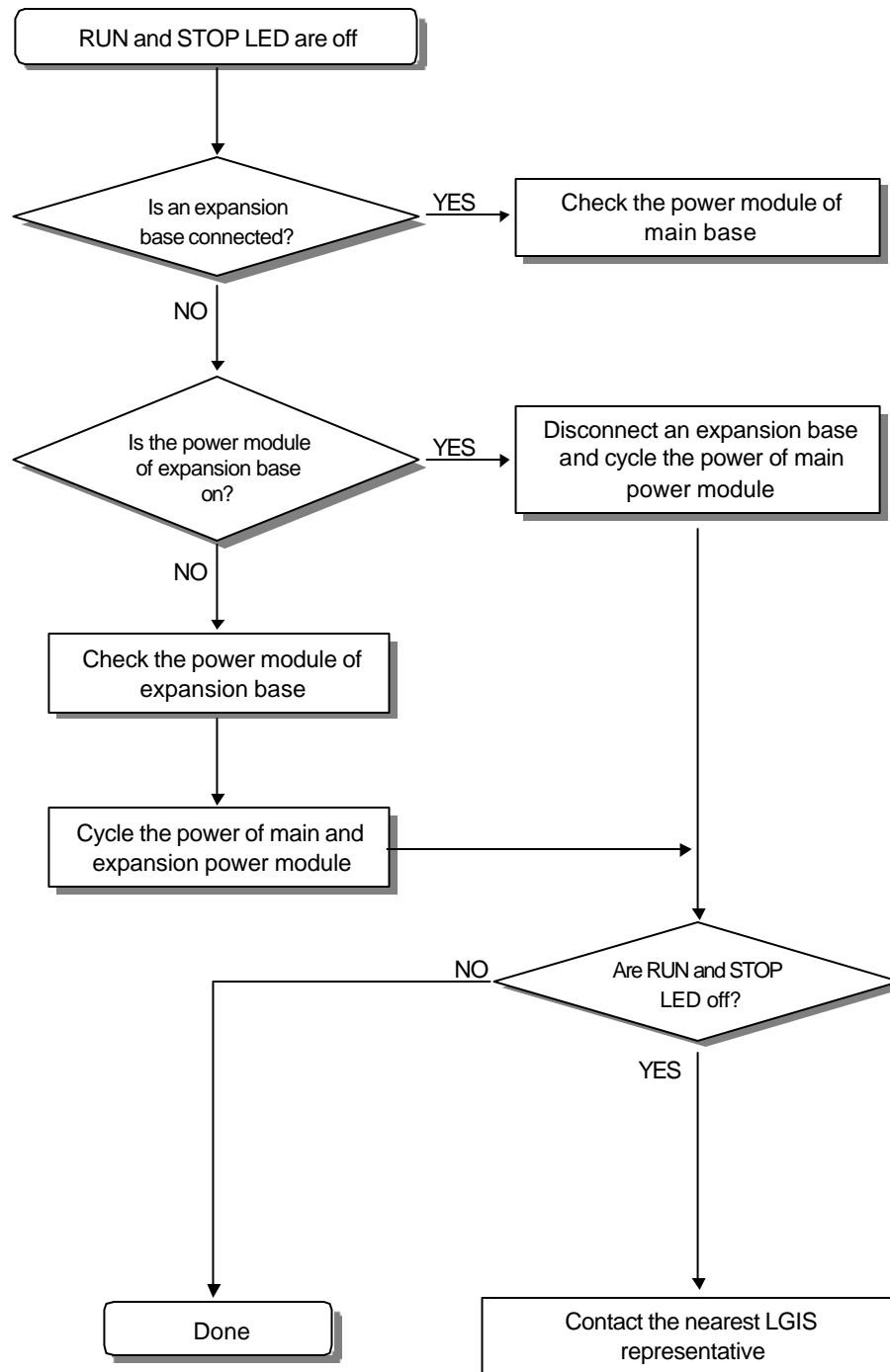

12.2.4 The load of the output module is not operating

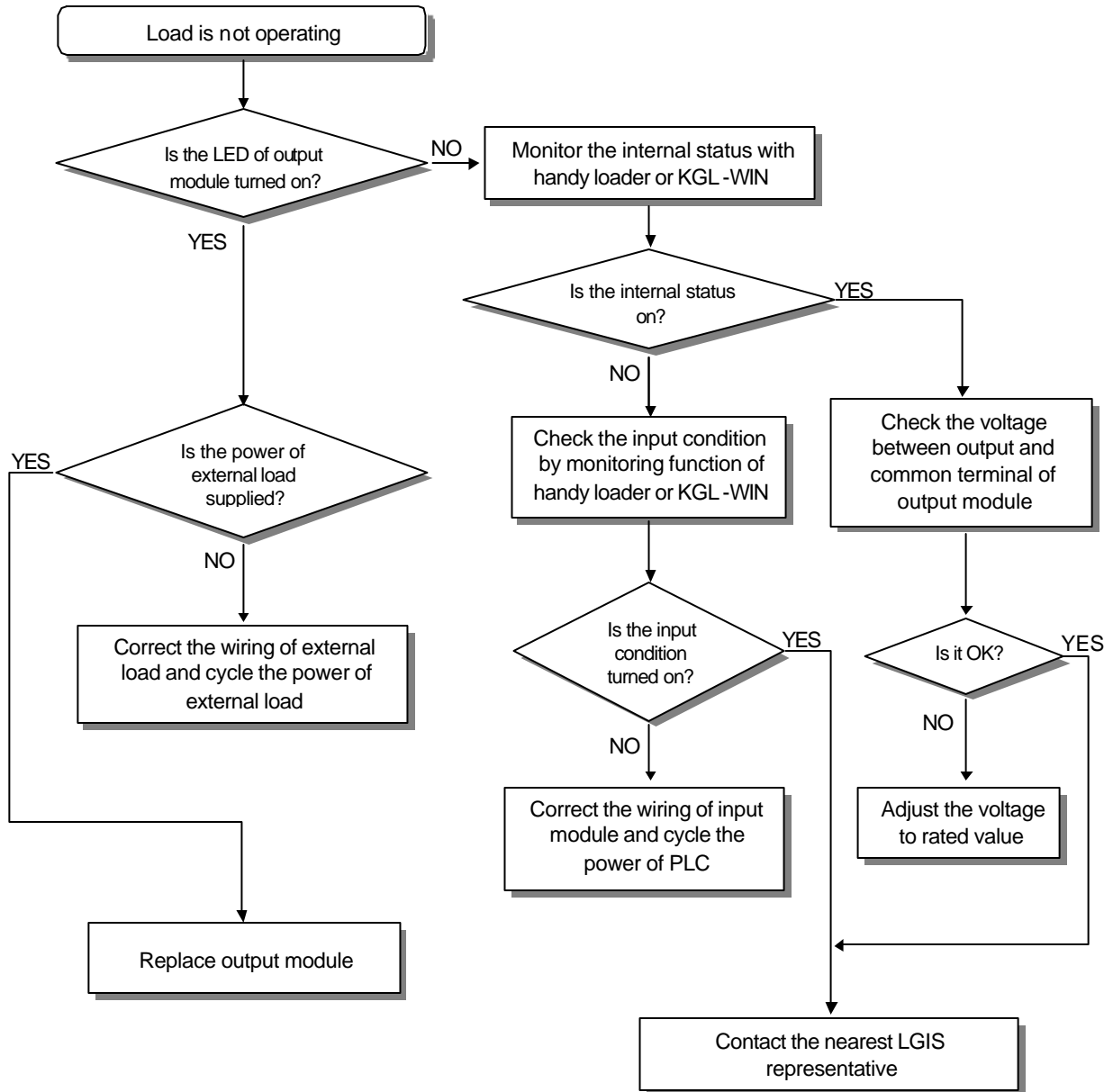

Remark

Please refer the chapter 12.4 for troubleshooting when the input signal or external output load doesn't turn off.

12.2.5 Program download is unable

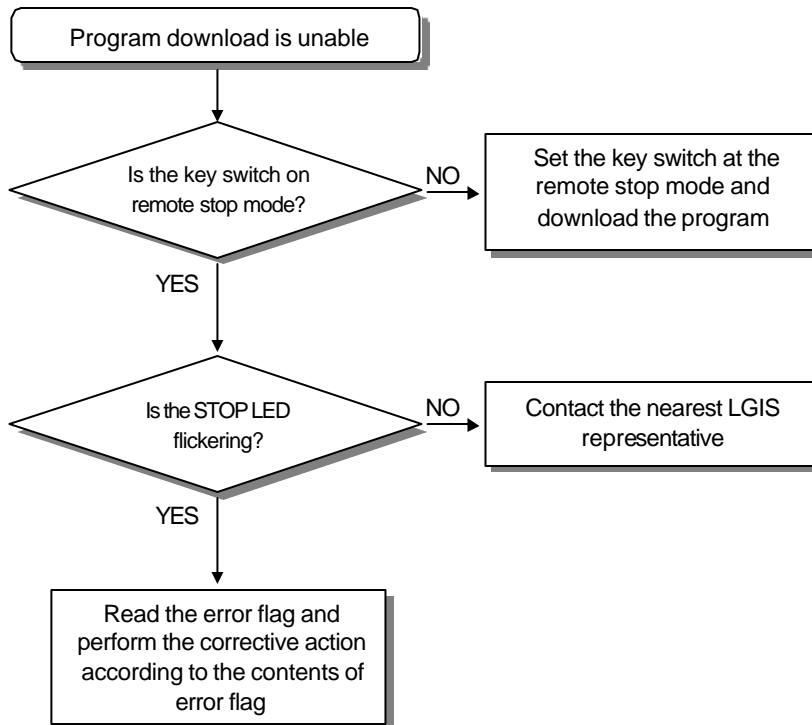

12.4 Troubleshooting examples

This chapter shows some typical examples

12.4.1 Input circuit troubles and corrective actions

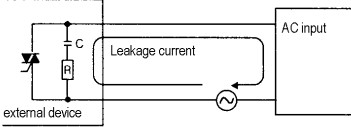
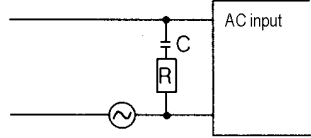
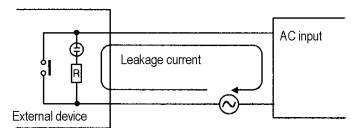
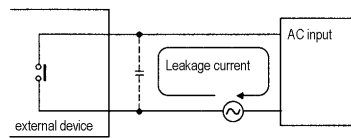
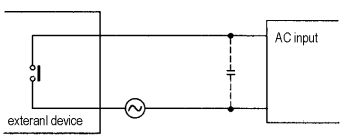
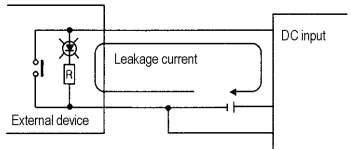
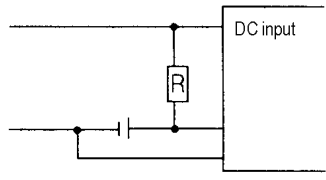
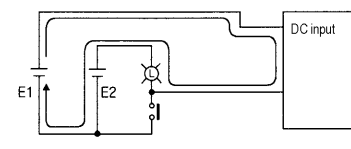
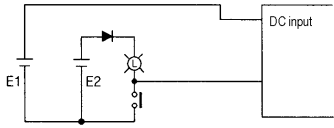
Condition	Cause	Corrective Action
Input signal does not turn OFF	Leakage current of external device (such as a drive by non-contact switch) 	<ul style="list-style-type: none"> Connect an appropriate register and capacity which will make the voltage across the terminals of the input module lower than 
Input signal does not turn OFF	Leakage current of external device (Drive by a limit switch with neon lamp) 	<ul style="list-style-type: none"> C and R values are determined by the leakage current value - Reminded value C : 0.1 ~ 0.47uF R : 47 ~ 120Ω (1/2W) Or make up another independent display circuit
Input signal does not turn OFF	Leakage current due to line capacity of wiring cable 	<ul style="list-style-type: none"> Power supply is located on the external device side as shown below 
Input signal does not turn OFF	Leakage current of external device (Drive by switch with LED indicator) 	<ul style="list-style-type: none"> Connect an appropriate register which will make the voltage across input module terminal and common higher than the OFF voltage, as shown below 
Input signal does not turn OFF	<ul style="list-style-type: none"> Sneak current due to the use of two different power supplies  <ul style="list-style-type: none"> E1 > E2, Sneak current 	<ul style="list-style-type: none"> Use only one power supply Connect a sneak current prevention diode(Figure below) 

12.4.2 Output circuit troubles and corrective actions

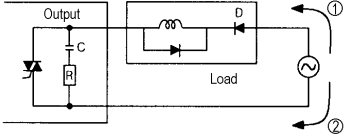
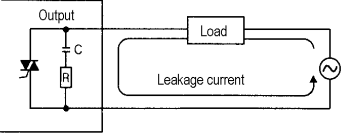
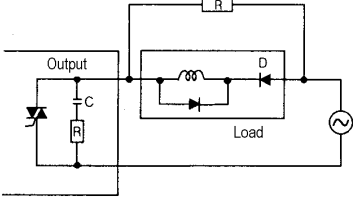
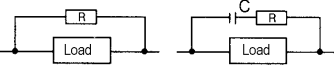
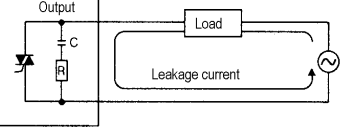
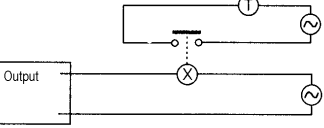
Condition	Cause	Corrective Action
<p>When the output is Off, excessive voltage is applied to the load</p> <p>The load does not turn OFF</p>	<ul style="list-style-type: none"> • Load is half-wave rectified inside (in some cases, it is true of a solenoid) • When the polarity of the power supply is as shown in ㄨ, C is charged. When the polarity is as shown in ㄣ, the voltage charged in C plus the line voltage are applied across D. Max voltage is approx. $2\sqrt{2}$ times of rated voltage  <p>If a resistor is used in this way, it does not cause a problem to the output element. But it may make the performance of the diode(D), which is built in the load, drop to cause problems</p> <ul style="list-style-type: none"> • Leakage current by surge absorbing circuit which is connected to output element in parallel 	<ul style="list-style-type: none"> • Connect registers of tens to hundreds kΩ across the load in parallel  <ul style="list-style-type: none"> • Connect C and R across the load, which are of registers of tens kΩ <p>When the wiring distance from the output module to the load is long, there may be a leakage current due to the line capacity</p> 
<p>When the load is C-R type timer, time constant fluctuates</p>	<ul style="list-style-type: none"> • Leakage current by surge absorbing circuit which is connected to output element in parallel 	<ul style="list-style-type: none"> • Drive the C-R timer using the relay. • Use other timer than the C-R timer. <p>Some timers have half-wave rectified internal circuits therefore, be cautious.</p> 

(Continued)

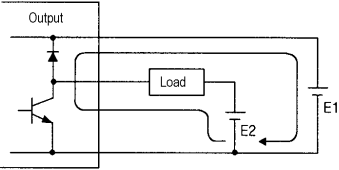
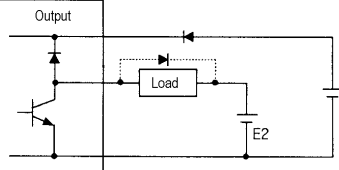
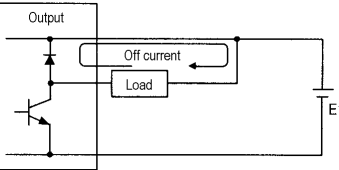
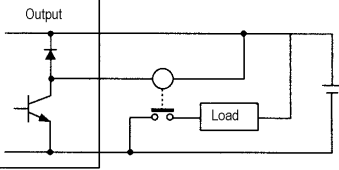
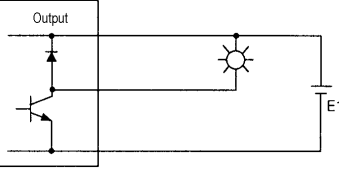
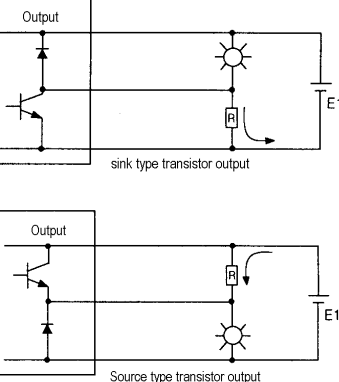
Condition	Cause	Corrective Action
<p>The load does not turn OFF</p>	<ul style="list-style-type: none"> • Sneak current due to the use of two different power supplies  <ul style="list-style-type: none"> • $E1 < E2$: sneak current • E1 is switched Off and E2 is switched ON : sneak current 	<ul style="list-style-type: none"> • Use only one power supply • Connect a sneak current prevention diode(Figure below)  <p>If the load is the relay, etc, connect a counter-electromotive voltage absorbing code as show by the dot line</p>
<p>Off response time of the load is long</p>	<ul style="list-style-type: none"> • Over current at Off state [when a large current fluid load (L/R is large) such as solenoid is directly driven with the transistor output]  <ul style="list-style-type: none"> • The off response time can be delayed by one or more second as some loads make the current flow across the diode at the off time of the transistor output 	<ul style="list-style-type: none"> • Insert a small L/R magnetic relay and drive the load using the same contact 
<p>Output transistor is destroyed</p>	<p>Surge current of the white lamp</p>  <p>A surge current of 10 times or more when turned ON.</p>	<ul style="list-style-type: none"> • To suppress the surge current make the dark current of 1/3 to 1/5 rated current flow  <p>sink type transistor output</p> <p>Source type transistor output</p>

12.5 Error code list

Error Code	Error	CPU state	Message	Cause	Corrective Actions
0001h	Internal system error	Stop	SYSTEM ERROR	Fault of some area of operating ROM, or HW defect	Contact the service center.
0002h	OS ROM error	Stop	OS ROM ERROR	Internal system ROM is defected	Contact the service center.
0003h	OS RAM error	Stop	OS RAM ERROR	Internal system RAM is defected	Contact the service center.
0004h	Data RAM error	Stop	DATA RAM ERROR	Data RAM is defected	Contact the service center.
0005h	Program RAM error	Stop	PGM RAM ERROR	Program RAM is defected	Contact the service center.
0006h	Gate array error	Stop	G/A ERROR	Defect of dedicated LSI for sequence instruction processing	Contact the service center.
0007h	Sub rack power down error	Stop	SUB POWER ERROR	Extension Rack Power down or Error	Check the power of the extension rack
0008h	OS WDT error	Stop	OS WDT ERROR	CPU OS watch dog error	Turn the power off and restart the system. Contact the service center.
0009h	Common RAM error	Stop	COMMON RAM ERROR	Common RAM interface error	Contact the service center.
000Ah	Fuse break error	Continue (stop)	I/O FUSE ERROR	Break of fuse used in output units or Mixed I/O	Check the fuse LED of the unit. Turn the power off and replace the fuse.
000Bh	Instruction code error	Stop	OP CODE ERROR	Instructions unreadable by the CPU are included. (during execution)	Contact the service center.
000Ch	Flash memory error(during execution)	Stop	USER MEM ERROR	Read to/Write from the inserted Flash memory is not performed.	Check and replace the flash memory.
0010h	I/O slot error	Stop	I/O SLOT ERROR	← Mounting/dismounting of I/O units during operation, or connection fault ↑ I/O unit defect or extension cable defect	← Turn the power off and mount the unit firmly, and restart the system. ↑ Replace the I/O unit or extension cable.
0011h	Maximum I/O error	Stop	MAX I/O ERROR	Points of mounted I/O units overrun the maximum I/O points. (FMM mounting number over error, MINI_MAP over.).	Replace the I/O unit.
0012h	Special card interface error	Stop	SPECIAL I/F ERROR	Special Card Interface error	Contact the service center.
0013h	FMM 0 I/F error	Stop	FMM 0 I/F ERROR	FMM 0 I/F Error	Contact the service center.
0014h	FMM 1 I/F error	Stop	FMM 1 I/F ERROR	FMM 1 I/F Error	Contact the service center.

(Continued)

Error Code	Error	CPU state	Message	Cause	Corrective Actions
0015h	FMM2 I/F error	Stop	FMM2 I/F ERROR	FMM 2 I/F Error	Contact the service center.
0016h	FMM3 I/F error	Stop	FMM3 I/F ERROR	FMM 3 I/F Error	Contact the service center.
0020h	Parameter Error	Stop	PARAMETER ERROR	A written parameter has changed, or checksum error	Correct the content of the parameter.
0021h	I/O Parameter Error	Stop (continue)	I/O PARAMETER ERROR	When the power is applied or RUN starts, I/O unit reservation information differs from the types of real loaded I/O units.	Correct the content of the parameter, or reallocate or replace the I/O unit.
0022h	Maximum I/O Over	Stop	I/O PARAMETER ERROR	The point of the reserved I/O information or real loaded I/O units overruns the maximum I/O point.	Correct the content of the parameter.
0023h	FMM0 Parameter Error	Stop	FMM0 PARAMETER ERROR	FMM 0 Parameter Error	Correct the parameter.
0024h	FMM1 Parameter Error	Stop	FMM1 PARAMETER ERROR	FMM 1 Parameter Error	Correct the parameter.
0025h	FMM2 Parameter Error	Stop	FMM2 PARAMETER ERROR	FMM 2 Parameter Error	Correct the parameter.
0026h	FMM3 Parameter Error	Stop	FMM3 PARAMETER ERROR	FMM 3 Parameter Error	Correct the parameter.
0030h	Operation Error	Stop	OPERATION ERROR	<ul style="list-style-type: none"> • A digit of other than 0 to 9 has met during BCD conversion. • An operand value is outside the defined operand range. 	Correct the content of the error step.
0031h	WDT Over	Continue (stop)	WDT OVER ERROR	Scan time has overrun the watch dog time.	Check the maximum scan time of the program and modify the program or insert programs.
0032h	Error of Program Change during run.	Stop	PGM CHANGE ERROR	An error has occurred at program change during run. (NO SBRT, JME and END ..).	Program replacement has not been completed during run. (JMP ~ JME, FOR ~ NEXT, CALLx and SBRTx ..).
0033h	Program Check Error	Continue	CODE CHECK ERROR	An error has occurred while checking a program.	Correct the error.

(Continued)

Error Code	Error	CPU state	Message	Cause	Corrective Actions
0040h	Code Check Error	Stop	CODE CHECK ERROR	An instruction unreadable by the CPU is included.	Correct the error step.
0041h	Missing the END instruction in the program.	Stop	MISSEND ERROR	The program does not have the END instruction.	Insert the END instruction at the bottom of the program.
0042h	Missing the RET instruction in the program.	Stop	MISSRET ERROR	The subroutine does not has the RET instruction at its bottom.	Insert the END instruction at the bottom of the program.
0043h	Missing the SBRT instruction in the subroutine program.	Stop	MISS SBRT ERROR	The subroutine does not has the SBRT instruction.	Insert the SBRT instruction.
0044h	The JMP ~ JME instruction error	Stop	JMP(E) ERROR	The JMP ~ JME instruction error	Correct the JMP ~ JME instruction.
0045h	The FOR ~ NEXT instruction error	Stop	FOR-NEXT ERROR	The FOR ~ NEXT instruction error	Correct the FOR ~ NEXT instruction.
0046h	The MCS ~ MCSCLR instruction error	Stop	MCS-MCSCLR ERROR	The MCS ~ MCSCLR instruction error	Correct the MCS ~ MCSCLR instruction.
0047h	The MPUSH ~ MPOP instruction error	Stop	MPUSH ~ MPOP ERROR	The MPUSH ~ MPOP instruction error	Correct the MPUSH ~ MPOP instruction
0048h	Dual coil error	Stop	DUAL COIL ERROR	Timer or counter has been duplicated.	Correct timer, counter.
0049h	Syntax error	Stop	SYNTAX ERROR	Input condition error, or too much use of LOAD or AND(OR) LOAD.	Check and correct the program.
0050h	Battery error	Continue	BATTERY ERROR	Backup battery voltage error	Replace the battery under the present condition.

Chapter 13 RS-232C function of K200S

13 RS-232C function of K200S	13-1
13.1 Introduction	13-1
13.2 System configuration	13-2
13.2.1 Connection with PC (without handshake function).....	13-2
13.2.2 Connection with monitoring unit (with handshake function)	13-2
13.3 Pin assignment	13-3
13.3.1 Pin-out of K200S RS-232C connector.....	13-3
13.3.2 Connection without handshake function.....	13-3
13.3.3 Connection with handshake function	13-3
13.4 Frame structure	13-4
13.4.1 General structures	13-4
13.5 Instruction list	13-5
13.6 Data address structure	13-6
13.6.1 Start of data	13-6
13.6.2 Device type.....	13-6
13.6.3 Data type.....	13-7
13.6.4 Device number.....	13-7
13.7 Examples of command execution	13-8
13.7.1 Read single device (RSS)	13-8
13.7.2 Read continuous devices (RSB).....	13-11
13.7.3 Write single device (WSS).....	13-14
13.7.4 Write continuous device (WSB)	13-17
13.7.5 Register monitoring number.....	13-20
13.7.6 Execute monitoring	13-23
13.7.7 Read the status of PLC (RST)	13-25
13.8 Error code list	13-28

13 RS-232C function of K200S

13.1 Introduction

The K200S A and C type (K3P-07AS and K3P-07CS) have built-in RS-232C communication function and those CPU modules can perform RS-232C communication without external Cnet I/F module. Although the all functions of external Cnet I/F module are not supported, it is very useful function for users who want to construct simple and low-cost RS-232C network. The K200S A and C type CPU provide following RS-232C communication functions;

- Individual reading
- Continuous reading
- Individual writing
- Continuous writing
- CPU operation status monitoring
- Register monitoring number
- Monitoring execution

Remark

Because the built-in RS-232C communication functions only support a part of all functions of external Cnet module, there are some limitations as followings;

1. Only RS-232C protocol is supported. (K200S B type CPU, K3P-07BS, supports RS-422/485 protocol)
2. Only 1:1 communication is available.
3. The K200S CPU module has only one RS-232C connector, loader (KGL-WIN or handy loader) communication and the built-in RS-232C communication shares the RS-232C connector. Please refer chapter 13.3 for detail pin-out of RS-232C connector.
4. Some error codes of external Cnet module and built-in RS-232C communication are different each other. Therefore, please be sure to refer an error code list of the user's manual of corresponding unit.

13.2 System configuration

The system configuration can be divided in 2 types as following;

13.2.1 Connection with PC (without handshake function)

With this system configuration, a computer program for communication can be a user's own program (it may be written with C or other programming language), or commercial MMI programs such as FAM, CIMON, or etc.

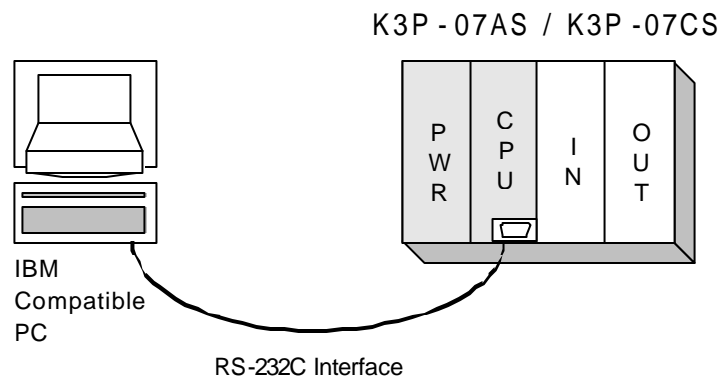

13.2.2 Connection with monitoring unit (with handshake function)

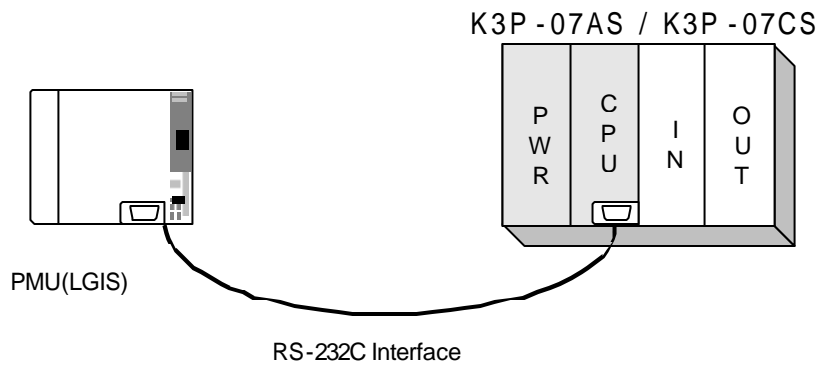

13.3 Pin assignment

13.3.1 Pin-out of K200S RS-232C connector

Pin number	Function	Pin number	Function
1	N.C.	6	N.C.
2	Rx for loader communication	7	Tx for built-in Cnet function
3	Tx for loader communication	8	N.C.
4	RX for built-in Cnet function	9	N.C.
5	Ground (common)		

13.3.2 Connection without handshake function

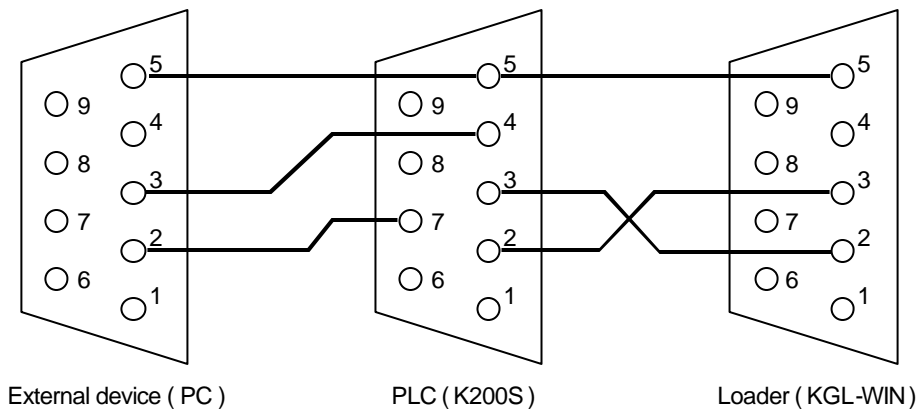

13.3.3 Connection with handshake function

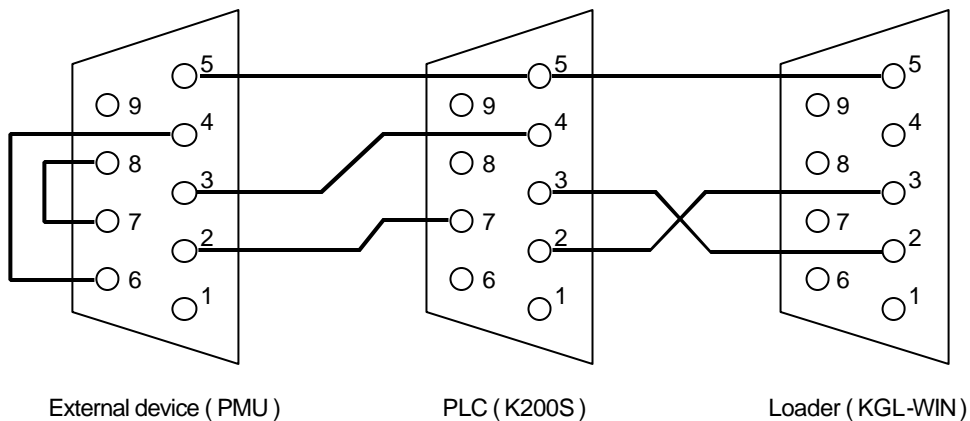

13.4 Frame structure

13.4.1 General structures

- 1) Request frame (External devices → CPU)

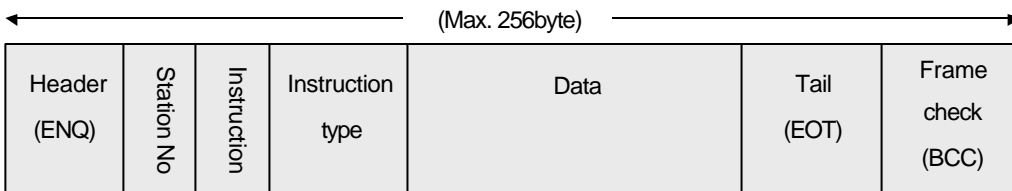

- 2) ACK response frame (CPU → External devices, when normal data is received)

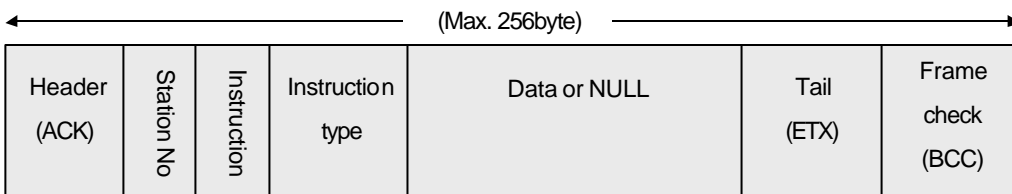

- 3) NAK response frame (CPU → External devices, when abnormal data is received)

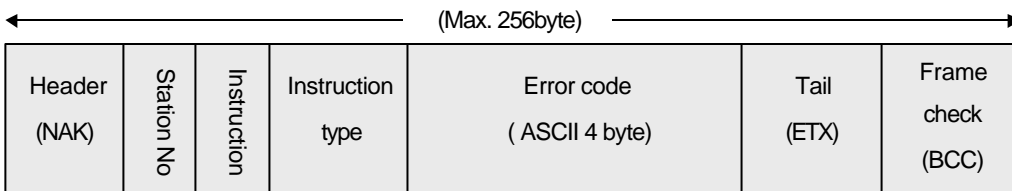

Remark

The following table describes several control codes. They are importantly used in serial communication, so they should be well acquainted.

Code	Hex value	Original word	Description
ENQ (header)	h05	Enquire	Start of request frame
ACK (header)	h06	Acknowledge	Start of ACK response frame
NAK (header)	h15	Not acknowledge	Start of NAK response frame
EOT (tail)	h04	End of text	End of request frame
ETX (tail)	h03	End text	End of response frame

13.5 Instruction list

The following table shows instructions used in K200S dedicated built-in Cnet communication.

Item		Instruction				Description
		Main instruction		Instruction type		
		Symbol	ASCII code	Symbol	ASCII code	
Read	Single	r (R)	h72 (h52)	SS	h5353	Read a single bit or word from PLC
	Continuous	r (R)	h72 (h72)	SB	h5342	Read a block (multiple bits or words) from PLC
Write	Single	w (W)	h77 (h57)	SS	h5353	Write a single bit or word to PLC
	Continuous	w (W)	h77 (h57)	SB	h5342	Write a block (multiple bits or words) to PLC
Monitoring number registration		x (X)	h78 (h58)	–	–	Register devices to be monitored
Monitoring execution		y (Y)	h79 (h59)	–	–	Execute monitoring function
Read CPU status		r (R)	h72 (h52)	ST	h5354	Read a status of CPU module

Remark

- The CPU doesn't care capital or small letter in frame. For example, '%MW100' and '%mw100' have same meaning. Only one exception is main instruction. If a small letter is used, the BCC check is performed.
- When read/write a bit, the last digit of address should be a capital letter.

Example) %mx001f (X)
 %mx001F (O)

13.6 Data address structure

This chapter describes how to assign the address of device when performs read / write function.

[Example of data structure]

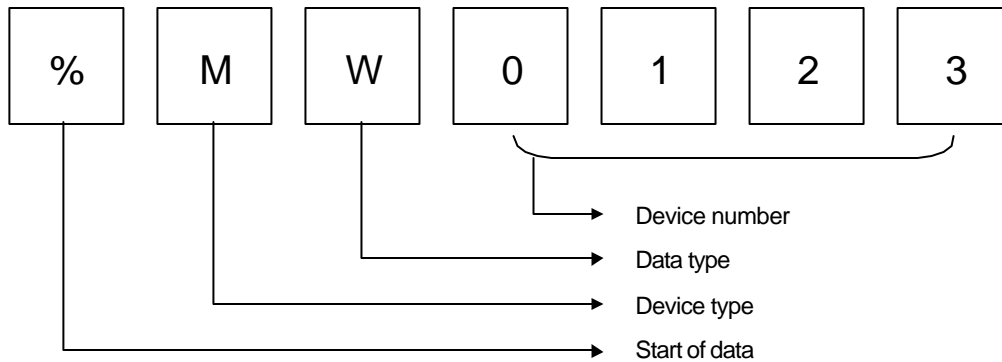

13.6.1 Start of data

The '%' symbol indicates the start of data address. It must be located the start of data address.

13.6.2 Device type

Device type	Device range	Remark
P (I/O relay)	%PW0000 ~ %PW0031 (32 words) %PX0000 ~ %PX031F (32× 16 bits)	Read / Write
M (auxiliary relay)	%MW0000 ~ %MW0191 (192 words) %MX0000 ~ %MX191F (192× 16 bits)	Read / Write
K (keep relay)	%KW0000 ~ %KW0031 (32 words) %KX0000 ~ %KX031F (32× 16 bits)	Read / Write
L (link relay)	%LW0000 ~ %LW0063 (64 words) %LX0000 ~ %LX063F (64× 16 bits)	Read / Write
F (special relay)	%FW0000 ~ %FW0063 (64 words) %FX0000 ~ %FX063F (64× 16 bits)	Read
T (timer contact relay)	%TX0000 ~ %TX0255 (256 bits)	Read / Write
T (timer elapsed value)	%TW0000 ~ %TW0255 (256 words)	Read / Write
C (counter contact relay)	%CX0000 ~ %CX0255 (256 bits)	Read / Write
C (counter elapsed value)	%CW0000 ~ %CW0256 (256 words)	Read / Write
S (step controller)	%SW0000 ~ %SW0099 (100 sets)	Read / Write
D (data register)	%DW0000 ~ %DW4999 (5000 words)	Read / Write

Remark

When read or write S device, address should be assigned in word type although step controllers are handled as bit. See following examples for details.

1. Turn on S00.07 : Write 07 to the %SW0000
2. Turn on S05.15 : Write 15 to the %SW0005
3. Clear S10 set : Write 00 to the %SW0010
4. Read S23 set : Read the %SW0023. Returned decimal number shows which bit is turned on. (If S23.47 is on, CPU will return h3437=47)

13.6.3 Data type

Symbol	Data type	Examples
X (h58)	bit	%mx0003, %PX001C, %TX0002
W (h57)	word	%mw0003, %PW0012, %CW0120

13.6.4 Device number

When the data type is assigned as word, all device number is expressed in decimal number. When the data type is bit, however, the last digit of device number is hexadecimal number. (other digits are decimal number)

Please refer the chapter 4.6.1 ' memory configuration' or the ' MASTER-K programming manual' for details.

Examples) %MX010E : indicates bit E (15th bit) of M010 word
 %MW0100 : indicates M100 word
 %DW0200 : indicates D0200 word
 %PX031A : indicates bit A (10th bit) of P031 word
 %TX0012 : indicates output relay of timer 12
 %TW0012 : indicates elapsed value of timer 12
 %SW0024 : indicates 24th set (S24.00 ~ S24.99) of step controller

Remark

In the above examples, device numbers are consist of 4 digits and it is the recommended format of MASTER-K series. However, 2 ~ 8 digits can be used as device number.

Example) %MX01 = %MX001 = ... = %MX0000001 = %MX00000001
 %DW31 = %DW031 = ... = %DW0000031 = %DW00000031

13.7 Examples of command execution

13.7.1 Read single device (RSS)

1) Introduction

This command is used for reading single devices. Max. 16 separated devices can be read with a command. See the chapter 13.6 for accessible device type.

2) Request format (External device → PLC)

Format name	Header	Station number	Main instruction	Instruction type	Number of blocks	Length of device definition	Device definition	Tail	Frame check
Frame example	ENQ	h20	R (r)	SS	h01	h06	%MW100	EOT	BCC
ASCII value	h05	h3230	h52 (h72)	h5353	h3031	h3036	h254D57313030	h04	

1 block
 (Max. 16 blocks available)

BCC : When the main instruction is small character (r), the lower byte of summation from ENQ to EOT is converted into ASCII format and added to frame as BCC check.

Number of blocks : It indicates how many blocks (block : length of device definition + device definition) are following, and maximum number of blocks is 16. Therefore, the range of block number is h01 ~ h10 (ASCII code : h3031 ~ h3130).

Length of device definition : It indicates that the device definition include ' % ' occupies how many bytes after converted to ASCII code (1byte = 2 ASCII codes). The available range is h01 ~ h10 (ASCII format : h3031 ~ h3130)

Example : %MW000 = h06
 %MX0000 = h07

Device definition : It indicates an actual address to be read. It should be consist of ' % , device type (capital or small letter), and numbers only.

Remark

- The ' h ' is added to show the numeric data is hexadecimal format. When you write frame, please do not add ' h ' to actual numeric data.
- All blocks in one frame should have same data type. If the data type of first block is bit and that of second is word, an error will occurs.

3) Response format (PLC → External device : ACK response)

Format name	Header	Station number	Main instruction	Instruction type	Number of blocks	Length of data	Data	Tail	Frame check
Frame example	ACK	h20	R (r)	SS	h01	h02	hA9F3	ETX	BCC
ASCII value	h06	h3230	h52 (h72)	h5353	h3031	h3032	h41394633	h03	

1 block
 (Max. 16 blocks available)

Station number, main instruction, instruction type, and number of blocks are same as the request format.

When the main instruction is small character (r), the lower byte of summation from ACK to ETX is converted into ASCII format and added to frame as BCC check.

The length of data indicates that the following data occupies how many bytes before converted to ASCII code. It is determined on basis of the data type included in request format.

Data type	Length of data
Bit (X)	1
Word (W)	2

In data area, the contents of assigned device are stored after converted to ASCII code.

Example : When the contents is h48B0, the ASCII code will be h34384230

Remark

Although the data type is bit, the data should be a byte because the minimum data unit is a byte. If the content of bit is 0, the data is h00 (ASCII code : h3030) and if the content is 1, the data is h01(ASCII code : h3031).

4) Response format (PLC → External device : NAK response)

Format name	Header	Station number	Main instruction	Instruction type	Error code (Hex 2 byte)	Tail	Frame check
Frame example	NAK	h20	R (r)	SS	h2232	ETX	BCC
ASCII value	h15	h3230	h52 (h72)	h5353	h32323332	h03	

Station number, main instruction, and instruction type are same as the request format.

When the main instruction is small character (r), the lower byte of summation from NAK to ETX is converted into ASCII format and added to frame as BCC check.

The error code is expressed as 2 byte of hexadecimal format (4bytes of ASCII codes) and indicates the type of error. Please refer the error code table for details.

5) Example

Read the contents of first word of P area (P000) and 21th word of M area (M020) from the PLC of that station number is h01. Assume the contents of P000 is h1234, and M020 is h3456. (No BCC check)

Request format (External device → PLC)

Format name	Header	Station number	Main instruction	Instruction type	Number of blocks	Length of device definition	Device definition	Length of device definition	Device definition	Tail
Frame example	ENQ	h01	R	SS	h02	h06	%PW000	h06	%MW020	EOT
ASCII value	h05	h3031	h52	h5353	h3032	h3036	h255057303030	h3036	h254D57303230	h04

Response format (PLC → External device : ACK response)

Format name	Header	Station number	Main instruction	Instruction type	Number of blocks	Length of data	Data	Length of data	Data	Tail
Frame example	ACK	h01	R	SS	h02	h02	h1234	h02	h3456	EXT
ASCII value	h06	h3031	h52	h5353	h3032	h3032	h31323334	h3032	h33343536	h03

Response format (PLC → External device : NAK response)

Format name	Header	Station number	Main instruction	Instruction type	Error code	Tail
Frame example	NAK	h01	R	SS	error code (2 byte)	ETX
ASCII value	h15	h3031	h52	h5353	ASCII value (4 byte)	h03

13.7.2 Read continuous devices (RSB)

1) Introduction

This command is used for reading continuous devices by assigning start address and word number. Only word data type is available for this command, and Max. 60 words can be read with one command.

2) Request format (External device → PLC)

Format name	Header	Station number	Main instruction	Instruction type	Length of device definition	Device definition	Number of data	Tail	Frame check
Frame example	ENQ	h10	R (r)	SB	h06	%MW100	h02	EOT	BCC
ASCII value	h05	h3130	h52 (h72)	h5342	h3036	h254D57313030	h3032	h04	

BCC : When the main instruction is small character (r), the lower byte of summation from ENQ to EOT is converted into ASCII format and added to frame as BCC check.

Length of device definition : It indicates that the device definition include '%' occupies how many bytes after converted to ASCII code (1byte = 2 ASCII codes). The available range is h01 ~ h10 (ASCII format : h3031 ~ h3130)

Example : %MW000 = h06
 %PW0000 = h07

Device definition : It indicates an actual address to be read. It should be consist of ' % , device type (capital or small letter), and numbers only.

Number of data : It indicates that how many words will be read from the start address. The range is h01 ~ h3C (1 ~ 60).

Remark

The continuous reading command does not support bit data type.

3) Response frame (PLC → External device : ACK response)

Format name	Header	Station number	Main instruction	Instruction type	Number of data	Data	Tail	Frame check
Frame example	ACK	h10	R (r)	SB	h04	h12345678	ETX	BCC
ASCII value	h06	h3130	h52 (h72)	h5342	h3034	h3132333435363738	h03	

Station number, main instruction, and instruction type are same as the request format. When the main instruction is small character (r), the lower byte of summation from ACK to ETX is converted into ASCII format and added to frame as BCC check.

Number of data : It indicates that the following data occupies how many bytes in hexadecimal format (before converted to ASCII code). It can be obtained by multiplying data type (1 word = 2 byte) and number of data in the request format.

Example : The number of data in request format = h02

The number of data in response format : $2 \times 2 = h04$

In data area, the hexadecimal data is stored in ASCII code format.

4) Response format (PLC → External device : NAK response)

Format name	Header	Station number	Main instruction	Instruction type	Error code (Hex 2 byte)	Tail	Frame check
Frame example	NAK	h10	R (r)	SB	h2232	ETX	BCC
ASCII value	h15	h3130	h52 (h72)	h5342	h32323332	h03	

Station number, main instruction, and instruction type are same as the request format. When the main instruction is small character (r), the lower byte of summation from NAK to ETX is converted into ASCII format and added to frame as BCC check.

The error code is expressed as 2 byte of hexadecimal format (4bytes of ASCII codes) and indicates the type of error. Please refer the error code table for details.

5) Example

Read the contents of 2 words from the first word of M area (M000), and the station number of PLC is 10 (h0A). Assume that the content of M000 is h1234 and M0001 is h5678.

Request format (External device → PLC)

Format name	Header	Station number	Main instruction	Instruction type	Length of device definition	Device definition	Number of data	Tail	Frame check
Frame example	ENQ	h0A	R (r)	SB	h06	%MW000	h02	EOT	BCC
ASCII value	h05	h3041	h52 (h72)	h5342	h3036	h254D57303030	h3032	h04	

Response format (PLC → External device : ACK response)

Format name	Header	Station number	Main instruction	Instruction type	Number of data	Data	Tail	Frame check
Frame example	ACK	h0A	R (r)	SB	h04	h12345678	ETX	BCC
ASCII value	h06	h3041	h52 (h72)	h5342	h3034	h3132333435363738	h03	

Response format (PLC → External device : NAK response)

Format name	Header	Station number	Main instruction	Instruction type	Error code	Tail	Frame check
Frame example	NAK	h0A	R (r)	SB	Error code (2 byte)	ETX	BCC
ASCII value	h15	h3041	h52 (h72)	h5342	ASCII value (4 byte)	h03	

13.7.3 Write single device (WSS)

1) Introduction

This command is used for writing single devices. Max. 16 separated devices can be written with a command.

2) Request format (External device → PLC)

Format name	Header	Station number	Main instruction	Instruction type	Number of blocks	Length of device definition	Device definition	Tail	Frame check
Frame example	ENQ	h20	W (w)	SS	h01	h06	%MW100	EOT	BCC
ASCII value	h05	h3230	h57 (h77)	h5353	h3031	h3036	h254D57313030	h04	

1 block
(Max. 16 blocks available)

BCC : When the main instruction is small character (w), the lower byte of summation from ENQ to EOT is converted into ASCII format and added to frame as BCC check.

Number of blocks : It indicates how many blocks (block : length of device definition + device definition) are following, and maximum number of blocks is 16. Therefore, the range of block number is h01 ~ h10 (ASCII code : h3031 ~ h3130).

Length of device definition : It indicates that the device definition include ' % ' occupies how many bytes after converted to ASCII code (1byte = 2 ASCII codes). The available range is h01 ~ h10 (ASCII format : h3031 ~ h3130)

Example : %MW000 = h06
 %MX0000 = h07

Device definition : It indicates an actual address where data is written. It should be consist of ' % ', device type (capital or small letter), and numbers only.

Data : This area contains the data to be written in ASCII code format. The length of data is determined on basis of data type. If the data type is word, the length is 2 byte (1word) and if the data type is bit, the length is 1 byte.

Example : Write 0 to a bit device : h00
 Write 1 to a bit device : h01
 Write h0001 to a word device : h0001
 Write h1234 to a word device : h1234

Remark

1. The 'h' is added to show the numeric data is hexadecimal format. When you write frame, please do not add 'h' to actual numeric data.
2. All blocks in one frame should have same data type. If the data type of first block is bit and that of second is word, an error will occurs.

3) Response format (PLC → External device : ACK response)

Format name	Header	Station number	Main instruction	Instruction type	Tail	Frame check
Frame example	ACK	h20	W (w)	SS	ETX	BCC
ASCII value	h06	h3230	h57 (h77)	h5353	h03	

Station number, main instruction, and instruction type are same as the request format. When the main instruction is small character (w), the lower byte of summation from ACK to ETX is converted into ASCII format and added to frame as BCC check.

4) Response format (PLC → External device : NAK response)

Format name	Header	Station number	Main instruction	Instruction type	Error code (Hex 2 byte)	Tail	Frame check
Frame example	NAK	h20	W (w)	SS	h2232	ETX	BCC
ASCII value	h15	h3230	h57 (h77)	h5353	h32323332	h03	

Station number, main instruction, and instruction type are same as the request format. When the main instruction is small character (w), the lower byte of summation from NAK to ETX is converted into ASCII format and added to frame as BCC check.

The error code is expressed as 2 byte of hexadecimal format (4bytes of ASCII codes) and indicates the type of error. Please refer the error code table for details.

5) Example

Write h1234 to the first word of P area (P000) of the PLC of that station number is h01.

(No BCC check)

Request format (External device → PLC)

Format name	Header	Station number	Main instruction	Instruction type	Number of blocks	Length of device definition	Device definition	Data	Tail
Frame example	ENQ	h01	W	SS	h01	h06	%PW000	h1234	EOT
ASCII value	h05	h3031	h57	h5353	h3031	h3036	h255057 303030	h31323334	h04

Response format (PLC → External device : ACK response)

Format name	Header	Station number	Main instruction	Instruction type	Tail
Frame example	ACK	h01	W	SS	EXT
ASCII value	h06	h3031	h57	h5353	h03

Response format (PLC → External device : NAK response)

Format name	Header	Station number	Main instruction	Instruction type	Error code	Tail
Frame example	NAK	h01	W	SS	error code (2 byte)	ETX
ASCII value	h15	h3031	h57	h5353	ASCII value (4 byte)	h03

13.7.4 Write continuous device (WSB)

1) Introduction

This command is used for writing continuous devices by assigning start address and word number. Only word data type is available for this command, and Max. 120 words can be written with one command.

2) Request format (External device → PLC)

Format name	Header	Station number	Main instruction	Instruction type	Length of device definition	Device definition	Number of data	Data	Fail	Frame check
Frame example	ENQ	h10	W (w)	SB	h06	%MW100	h02	h11112222	EOT	BCC
ASCII value	h05	h3130	h57 (h77)	h5342	h3036	h254D57 313030	h3032	h31313131 32323232	h04	

BCC : When the main instruction is small character (w), the lower byte of summation from ENQ to EOT is converted into ASCII format and added to frame as BCC check.

Length of device definition : It indicates that the device definition include '%' occupies how many bytes after converted to ASCII code (1byte = 2 ASCII codes). The available range is h01 ~ h10 (ASCII format : h3031 ~ h3130)

Example : %MW000 = h06
 %PW0000 = h07

Device definition : It indicates an actual start address where data is written. It should be consist of ' % ', device type (capital or small letter), and numbers only.

Number of data : It indicates that how many words to be written from the start address assigned by device definition. If the number of data is 5, for example, it means that the length of data is 5 words. The range is 0 ~ 60 words (h00 ~ h3C)

Data : This area contains the data to be written in ASCII code format.

Remark

The continuous writing command does not support bit data type.

3) Response format (PLC → External device : ACK response)

Format name	Header	Station number	Main instruction	Instruction type	Tail	Frame check
Frame example	ACK	h10	W (w)	SB	EXT	BCC
ASCII value	h06	h3130	h57 (h77)	h5342	h03	

Station number, main instruction, and instruction type are same as the request format

When the main instruction is small character (w), the lower byte of summation from ACK to ETX is converted into ASCII format and added to frame as BCC check.

4) Response format (PLC → External device : NAK response)

Format name	Header	Station number	Main instruction	Instruction type	Error code (Hex 2 byte)	Tail	Frame check
Frame example	NAK	h20	W (w)	SB	h2232	ETX	BCC
ASCII value	h15	h3230	h57 (h77)	h5342	h32323332	h03	

Station number, main instruction, and instruction type are same as the request format.

When the main instruction is small character (w), the lower byte of summation from NAK to ETX is converted into ASCII format and added to frame as BCC check.

The error code is expressed as 2 byte of hexadecimal format (4bytes of ASCII codes) and indicates the type of error. Please refer the error code table for details.

5) Example

Write hAA15 and h056F to the P000 and P001 of station number h01. (Without BCC)

Request format (External device → PLC)

Format name	Header	Station number	Main instruction	Instruction type	Length of device definition	Device definition	Number of data	Data	Tail
Frame example	ENQ	h01	W	SB	h06	%MW100	h02	h11112222	EOT
ASCII value	h05	h3031	h57	h5342	h3036	h254D57 313030	h3032	h31313131 32323232	h04

Response format (PLC → External device : ACK response)

Format name	Header	Station number	Main instruction	Instruction type	Tail
Frame example	ACK	h01	W	SB	EXT
ASCII value	h06	h3031	h57	h5342	h03

Response format (PLC → External device : NAK response)

Format name	Header	Station number	Main instruction	Instruction type	Error code (Hex 2 byte)	Tail
Frame example	NAK	h01	W	SB	h2232	ETX
ASCII value	h15	h3031	h57	h5342	h32323332	h03

13.7.5 Register monitoring number

1) Introduction

The monitoring number registration function is executed with the reading device command (RSS, RSB). User can register maximum 10 monitoring numbers, and execute registered monitoring number with the monitoring execution command.

2) Request format (External device → PLC)

Format name	Header	Station number	Main instruction	Registration number	Registration format	Tail	Frame check
Frame example	ENQ	h01	X (x)	h06		EOT	BCC
ASCII value	h05	h3031	h58 (78)	h3036		h04	

BCC : When the main instruction is small character (x), the lower byte of summation from ENQ to EOT is converted into ASCII format and added to frame as BCC check.

Registration number : Max. 10 numbers can be registered. If a registration number is already exist, the old registration number is replaced with new one.

Registration format

The registration format is same as the read single/continuous device command, but the header, station number, EOT, and BCC is not included. See the following examples for details.

a) Read single device

Main instruction	Instruction type	Number of blocks	Length of device definition	Device definition	...
R (r)	SS	h01	h06	%MW100	...
h52 (h72)	h5353	h3031	h3036	h254D57313030	

1 block
(Max. 16 blocks available)

b) Read continuous device

Main instruction	Instruction type	Length of device definition	Device definition	Number of data
R (r)	SB	h06	%MW100	h02
h52 (h72)	h5342	h3036	h254D57313030	h3032

3) Response format (PLC → External device : ACK response)

Format name	Header	Station number	Main instruction	Registration number	Tail	Frame check
Frame example	ACK	h01	X (x)	h06	ETX	BCC
ASCII value	h06	h3031	h58 (78)	h3036	h03	

Station number, main instruction, and registration number are same as the request format.

When the main instruction is small character (x), the lower byte of summation from ACK to ETX is converted into ASCII format and added to frame as BCC check.

4) Response format (PLC → External device : NAK response)

Format name	Header	Station number	Main instruction	Registration number	Error code	Tail	Frame check
Frame example	ACK	h01	X (x)	h06	h1132	ETX	BCC
ASCII value	h06	h3031	h58 (78)	h3036	h31313332	h03	

Station number, main instruction, and registration number are same as the request format.

When the main instruction is small character (x), the lower byte of summation from NAK to ETX is converted into ASCII format and added to frame as BCC check.

The error code is expressed as 2 byte of hexadecimal format (4bytes of ASCII codes) and indicates the type of error. Please refer the error code table for details.

5) Example

Register monitoring number 1 (Read D000 of station number 1)

Request format (External device → PLC)

Format name	Header	Station number	Main instruction	Registration number	Registration format				Tail	Frame check
					Instruction	Number of blocks	Length of device definition	Device definition		
Frame example	ENQ	h01	X (x)	h01	RSS	h01	h07	%DW0000	EOT	BCC
ASCII value	h05	h3031	h58 (78)	h3031	h525353	h3031	h3037	h445730303030	h04	

Response format (PLC → External device : ACK response)

Format name	Header	Station number	Main instruction	Registration number	Tail	Frame check
Frame example	ACK	h01	X (x)	h01	ETX	BCC
ASCII value	h06	h3031	h58 (78)	h3031	h03	

Response format (PLC → External device : NAK response)

Format name	Header	Station number	Main instruction	Registration number	Error code	Tail	Frame check
Frame example	ACK	h01	X (x)	h01	h1132	ETX	BCC
ASCII value	h06	h3031	h58 (78)	h3031	h31313332	h03	

13.7.6 Execute monitoring

1) Introduction

This command used for executing the pre-registered monitoring number. When this command is executed, the PLC returns the contents of devices that are registered with monitoring number.

2) Request format (External device → PLC)

Format name	Header	Station number	Main instruction	Registration number	Tail	Frame check
Frame example	ENQ	h01	Y (y)	h01	EOT	BCC
ASCII value	h05	h3031	h59 (79)	h3031	h04	

The registration number should be registered on PLC before executing monitoring.

BCC : When the main instruction is small character (y), the lower byte of summation from ENQ to EOT is converted into ASCII format and added to frame as BCC check.

3) Response format (PLC → External device : ACK response)

There are two response formats according to the type of registered format (read single device or read continuous devices).

When registered format is reading single device

Format name	Header	Station number	Main instruction	Registration number	Number of block	Length of data	Data	Tail	Frame check
Frame example	ACK	h01	Y (y)	h01	h02	h02	h9183	ETX	BCC
ASCII value	h06	h3031	h59 (79)	h3031	h3032	h3032	h39313833	h03	

1 block
(Max. 16 blocks available)

When registered format is reading continuous devices

Format name	Header	Station number	Main instruction	Registration number	Length of data	Data	Tail	Frame check
Frame example	ACK	h01	Y (y)	h01	h04	h9183AABB	ETX	BCC
ASCII value	h06	h3031	h59 (79)	h3031	h3034	h3931383341414242	h03	

4) Response format (PLC → External device : NAK response)

Format name	Header	Station number	Main instruction	Registration number	Error code	Tail	Frame check
Frame example	ENQ	h01	Y (y)	h01	h1132	EOT	BCC
ASCII value	h05	h3031	h59 (79)	h3031	h31313332	h04	

Station number, main instruction, and registration number are same as the request format.

When the main instruction is small character (y), the lower byte of summation from NAK to ETX is converted into ASCII format and added to frame as BCC check.

The error code is expressed as 2 byte of hexadecimal format (4bytes of ASCII codes) and indicates the type of error. Please refer the error code table for details.

5) Example

Execute the registration number 1 of station number 1. Assume that reading single device (D000, word) is already registered as number 1 and the contents of D000 is h3202. (No BCC check)

Request format (External device → PLC)

Format name	Header	Station number	Main instruction	Registration number	Tail
Frame example	ENQ	h01	Y	h01	EOT
ASCII value	h05	h3031	h59	h3031	h04

Response format (PLC → External device : ACK response)

Format name	Header	Station number	Main instruction	Registration number	Number of block	Length of data	Data	Tail
Frame example	ACK	h01	Y	h01	h01	h02	h3202	ETX
ASCII value	h06	h3031	h59	h3031	h3031	h3032	h33323032	h03

Response format (PLC → External device : NAK response)

Format name	Header	Station number	Main instruction	Registration number	Error code	Tail
Frame example	ENQ	h01	Y	h01	h1132	EOT
ASCII value	h05	h3031	h59	h3031	h31313332	h04

13.7.7 Read the status of PLC (RST)

1) Introduction

This command is used for reading the status of PLC such as operation status, error information, etc.

2) Request format (External device → PLC)

Format name	Header	Station number	Main instruction	Instruction type	Tail	Frame check
Frame example	ENQ	h01	R (r)	ST	EOT	BCC
ASCII value	h05	h3031	h52 (72)	h5354	h04	

BCC : When the main instruction is small character (r), the lower byte of summation from ENQ to EOT is converted into ASCII format and added to frame as BCC check.

3) Response format (PLC → External device : ACK response)

Format name	Header	Station number	Main instruction	Instruction type	Status data	Tail	Frame check
Frame example	ACK	h01	R (r)	ST	(Hex 20 bytes)	ETX	BCC
ASCII value	h06	h3031	h52 (72)	h5354	(ASCII code 40 bytes)	h03	

Station number, main instruction, and instruction type is same as those of the request format.

When the main instruction is small character (r), the lower byte of summation from ACK to ETX is converted into ASCII format and added to frame as BCC check.

Status data : The status data is consist of 20 byte of hexadecimal numbers. When the PLC returns, it is converted to the ASCII code, and its size is doubled (40 bytes). See the next page for detail of status data configuration.

[Data configuration of status data]

→ Byte

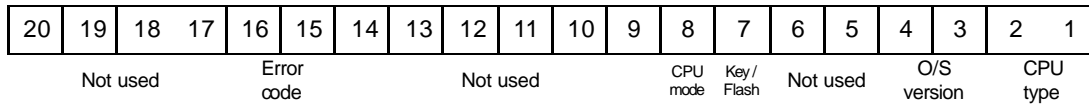

- CPU type

CPU type	Code
K200S A (K3P-07AS)	h3A
K200S B (K3P-07BS)	h3B
K200S B (K3P-07CS)	h3C
K300S A (K4P-15AS)	h33
K300S B (K4P-07AS)	h37
K1000S (K7P-30AS)	h32

- O/S version : (Use only lower 8 bits)

Example) O/S version 1.2

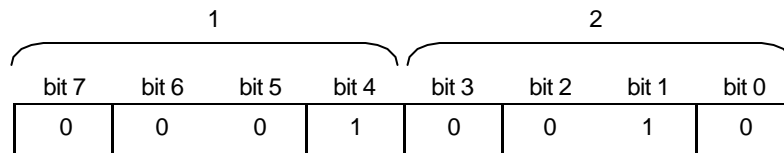

- Key / Flash

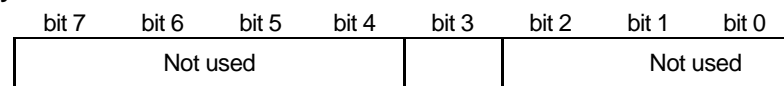

- 0 : Flash memory is mounted
- 1: Flash memory is not mounted

- 0 : Mode key is on local mode
- 1: Mode key is on remote mode

- CPU mode (Use only lower 4 bits) : Turn on one bit according to the operation

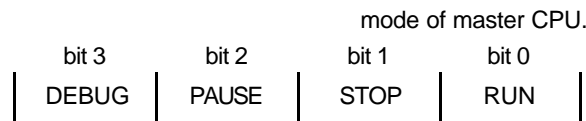

- Error code : Refer the chapter 12.5 ' Error code list'

4) Response format (PLC → External device : NAK response)

Format name	Header	Station number	Main instruction	Instruction type	Error code	Tail	Frame check
Frame example	NAK	h01	R (r)	ST	h1132	ETX	BCC
ASCII value	h15	h3031	h52 (72)	h5354	h31313332	h03	

Station number, main instruction, and instruction type is same as those of the request format.

When the main instruction is small character (r), the lower byte of summation from NAK to ETX is converted into ASCII format and added to frame as BCC check.

The error code is expressed as 2 byte of hexadecimal format (4bytes of ASCII codes) and indicates the type of error. Please refer the error code table for details.

5) Example

Read the CPU status of station number 1. (No BCC check)

Request format (External device → PLC)

Format name	Header	Station number	Main instruction	Instruction type	Tail
Frame example	ENQ	h01	R	ST	EOT
ASCII value	h05	h3031	h52	h5354	h04

Response format (PLC → External device : ACK response)

Format name	Header	Station number	Main instruction	Instruction type	Status data	Tail
Frame example	ACK	h01	R	ST	(Hex 20 bytes)	ETX
ASCII value	h06	h3031	h52	h5354	(ASCII code 40 bytes)	h03

Response format (PLC → External device : NAK response)

Format name	Header	Station number	Main instruction	Instruction type	Error code	Tail
Frame example	NAK	h01	R	ST	h1132	ETX
ASCII value	h15	h3031	h52	h5354	h31313332	h03

13.8 Error code list

The following table shows the error code list that PLC returns when NAK error occurs.

Error code	Error type	Description	Corrective action
h0001	PLC system error	It is unable to interface with PLC	Cycle the power of PLC
h0011	Data error	It is unable to convert ASCII codes to numeric data	Make sure that there is no characters other than alphabet, number, and ' %' in device definition and data
h0021	Instruction error	Wrong instruction	Check instruction if other character is used than R(r), W(w), S(s), X(s), and Y(y).
h0031	Instruction type error	Wrong instruction type	Revise instruction type
h1132	Device memory error	Wrong device memory assignment	Use correct device (P, M, L, K, T, C, F, S, or D)
h1232	Data length error	The length of data is 0 or exceeds 120 bytes (60 words)	Correct the length of data
h2432	Data type error	Wrong data type	Use bit or word data type
h7132	Device definition format error	Missing ' %' at the first of data definition	Correct the data definition format
h2232	Range over error	The data definition (P, M, L, K, T, C, F, S, or D) is out of its range	Correct the data definition not to exceed its range
h0190	Monitor execution error	The assigned monitor registration number is not exist or over the range (0 ~ 9)	Correct the monitor registration number
h0290	Monitor registration error	The registration number is out of range (0 ~ 9)	Correct the registration number
h6001	Syntax error	Device definition error Ex1) Wrong data type such as '%DX' or '%SX' (D and S area can be accessed with 'WORD' type) Ex2) Wrong address definition such as '%px0' (address definition should be 2 ~ 8 digit) Ex3) Try to write on F area (F area is read-only memory)	Correct the device definition format
h6010	Syntax error	Over-run or frame error	Cycle the power of PLC
h6020	Syntax error	Time-out error	Check the configuration of RS-232C port of external device Cycle the power of PLC
h6030	Syntax error	Wrong request frame	Check the request frame has ENQ and EOT

Error code	Error type	Description	Corrective action
h6040	Syntax error	The size of frame is over 256 byte	Revise the frame not to exceed 256 byte
h6050	Syntax error	BCC error	Check the BCC value

Chapter 14 RS-422/485 function of K200S

14	RS-422/485 function of K200S	14-1
14.1	Introduction.....	14-1
14.2	Features	14-1
14.3	Specification	14-1
14.4	Wiring	14-2
14.4.1	Wiring diagram of RS-422 network.....	14-2
14.4.2	Wiring diagram of RS-485 network.....	14-2
14.5	Pin-out of RS-422/485	14-3
14.6	Parameter setting	14-4
14.6.1	Basic parameter setting.....	14-4
14.6.2	High speed link parameter setting	14-5
14.7	Communication status flag.....	14-6
14.7.1	Error code (D4400 ~ D4415).....	14-6
14.7.2	Error count (D4416 ~ D4431)	14-6
14.7.3	Error information of slave PLC (D4432 ~ D4447).....	14-7
14.7.4	Error information of master PLC (D4448)	14-7
14.7.5	Transmission period (D4449 ~ D4454)	14-8
14.8	Monitoring the communication status.....	14-8

14 RS-422/485 function of K200S

This chapter will describe the built-in RS-422/485 communication function of K200S-B type. (A and C type don't support RS-422/485 communication)

14.1 Introduction

- 1) The K200S B-type (K3P-07BS) includes the RS-422/485 communication function, and it supports 1:N (master : slave) network between PLCs and external devices such as PC.
- 2) The communication parameters are set with the basic and high speed link parameter setting of KGL-WIN or KLD-150S
- 3) The MASTER-K dedicated protocol is used.

14.2 Features

- 1) User can define a data access block up to 64 block and the data access block is consist of 1 ~ 60 words.
- 2) Each data access blocks can have independent time-out setting.
- 3) Max. 32 station can join in the network.
- 4) There is a flag indicates the error count and error code of each high speed parameter setting and it is updated whenever an error occurs.
- 5) User can monitor the communication status of each parameter setting through the monitoring function of KGL-WIN.

14.3 Specification

Items	Specification	
Serial communication type	RS-422/485	
Protocol	MASTER-K dedicated protocol	
Synchronization	Asynchronous	
Transmission distance	Max. 500m	
Station number	Max. 32 stations (00 ~ 31)	
Data type	Data bit	8 bits
	Stop bit	1 bits
	Parity	None
Transmission speed	9600, 19200, 38400, 56000, 57600, 76800, 115200, 128000 bps (Selectable)	

14.4 Wiring

When construct a RS-422/485 network using K200S B type CPU module, please connect a terminal resistor at the both ends of network. It prevent the signal from distortion by reflected wave. The resistance value of terminal resistor should be equal to the characteristic impedance of network cable (usually 120Ω, 1/2W resistor)

14.4.1 Wiring diagram of RS-422 network

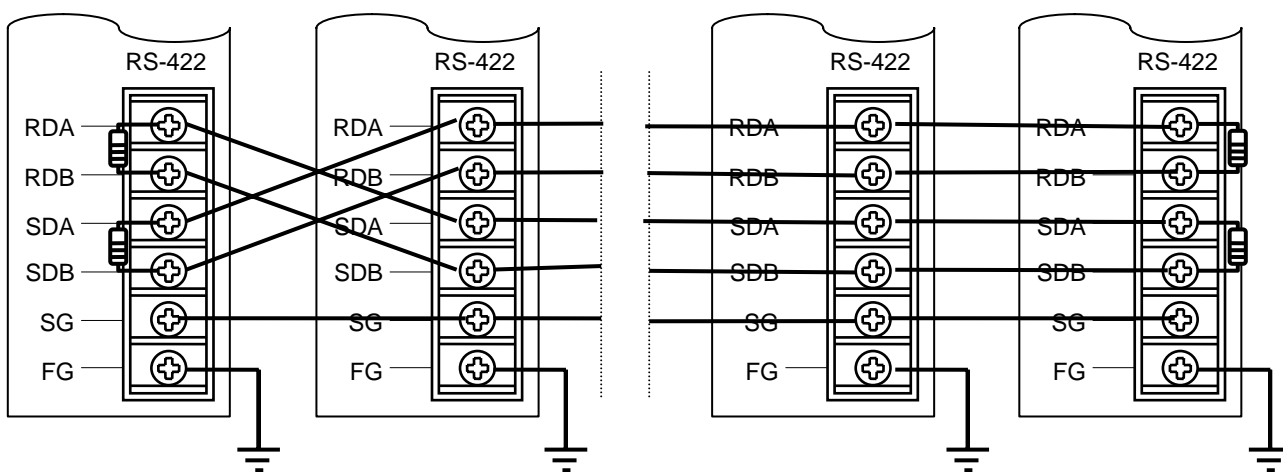

14.4.2 Wiring diagram of RS-485 network

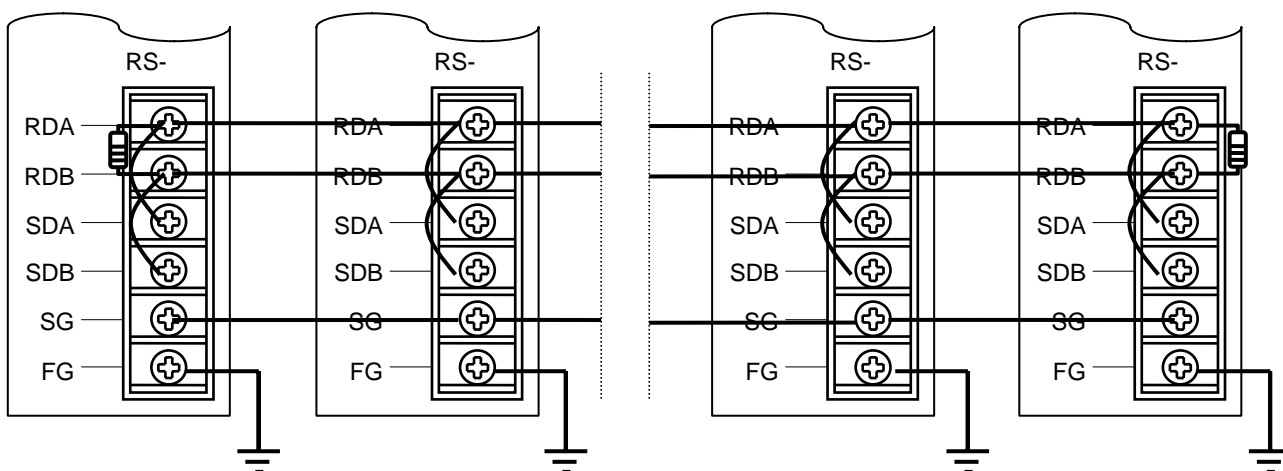

14.5 Pin-out of RS-422/485

The K200S B type CPU has 5-pin connector for RS-422/485 interface. The following table shows functions of each pin and connection with external device.

1) RS-422 network

Pin number	CPU	Signal direction	External device
1	RDA + (receive signal)	←	SDA + (send signal)
2	RDB – (receive signal)	←	SDA – (send signal)
3	SDA + (send signal)	→	RDA + (receive signal)
4	SDA – (send signal)	→	RDB – (receive signal)
5	S.G (signal ground)	↔	S.G (signal ground)

2) RS-485 network

Pin number	CPU	Signal direction	External device
1	RDA + (receive signal)	←	RS-485 +
2	RDB – (receive signal)		
3	SDA + (send signal)	→	RS-485 –
4	SDA – (send signal)		
5	S.G (signal ground)	↔	S.G (signal ground)

14.6 Parameter setting

- 1) The CPU module should be K200S B type (K3P-07BS)
- 2) Set station number, baud rate, and etc. at the basic parameter setting window
- 3) Set parameters related to data access block at the high speed link setting window.
- 4) Download parameter to the CPU. Then, the communication is executed automatically.

14.6.1 Basic parameter setting

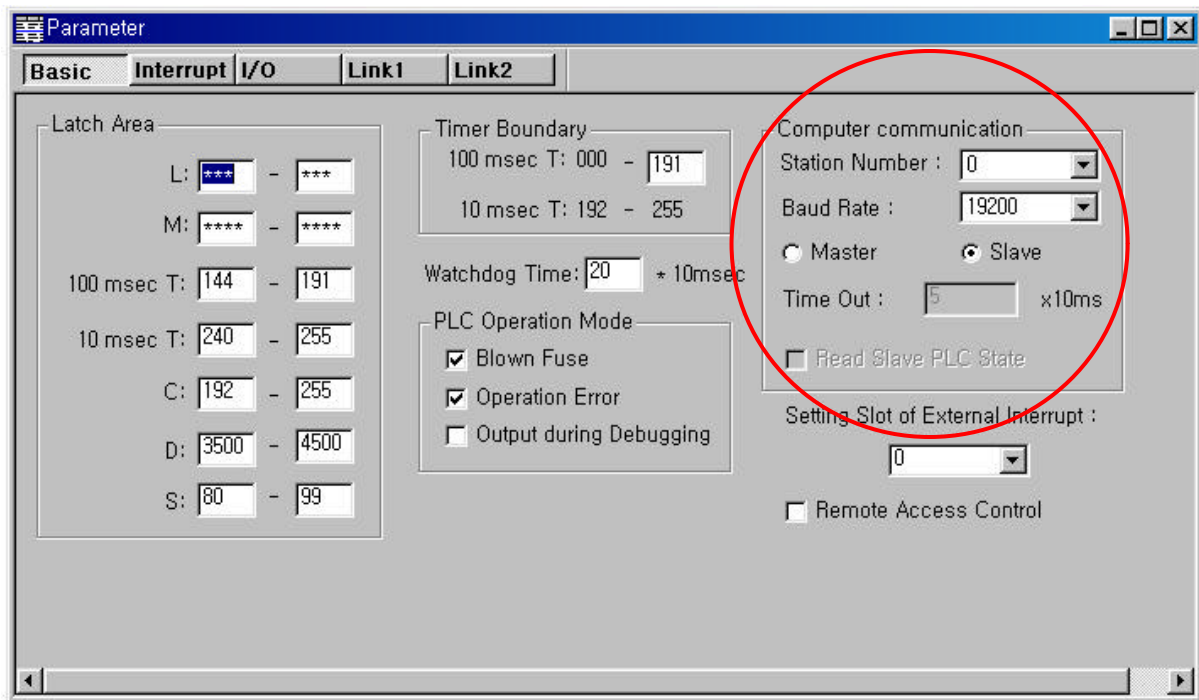

Station number : Set the station number of PLC (0 ~ 31 is available)

Baud rate : Set the transmit speed. (9600 ~ 128000 bps)

Master / slave : Set the PLC as master or slave station. If the PLC is set as master station, the communication type of high speed link 1 is fixed as RS-422/485.

Time out : Set the time out value. The PLC will output an error if there is no response during the setting time. Therefore, please consider the maximum send/receive time of network when set the time out value. The default value is 50 (500msec).

Read slave PLC state : Enable or disable the function to read the status of slave stations.

14.6.2 High speed link parameter setting

- 1) The high speed link 1 is used for RS-422/485 communication.
- 2) Max. 64 data access blocks can be established, and remain block number as blank.
- 3) Data size can be set within 0 ~ 60 words, and do not set the period.
- 4) All device can be set as Tx or Rx device, but F area can not be Rx device.

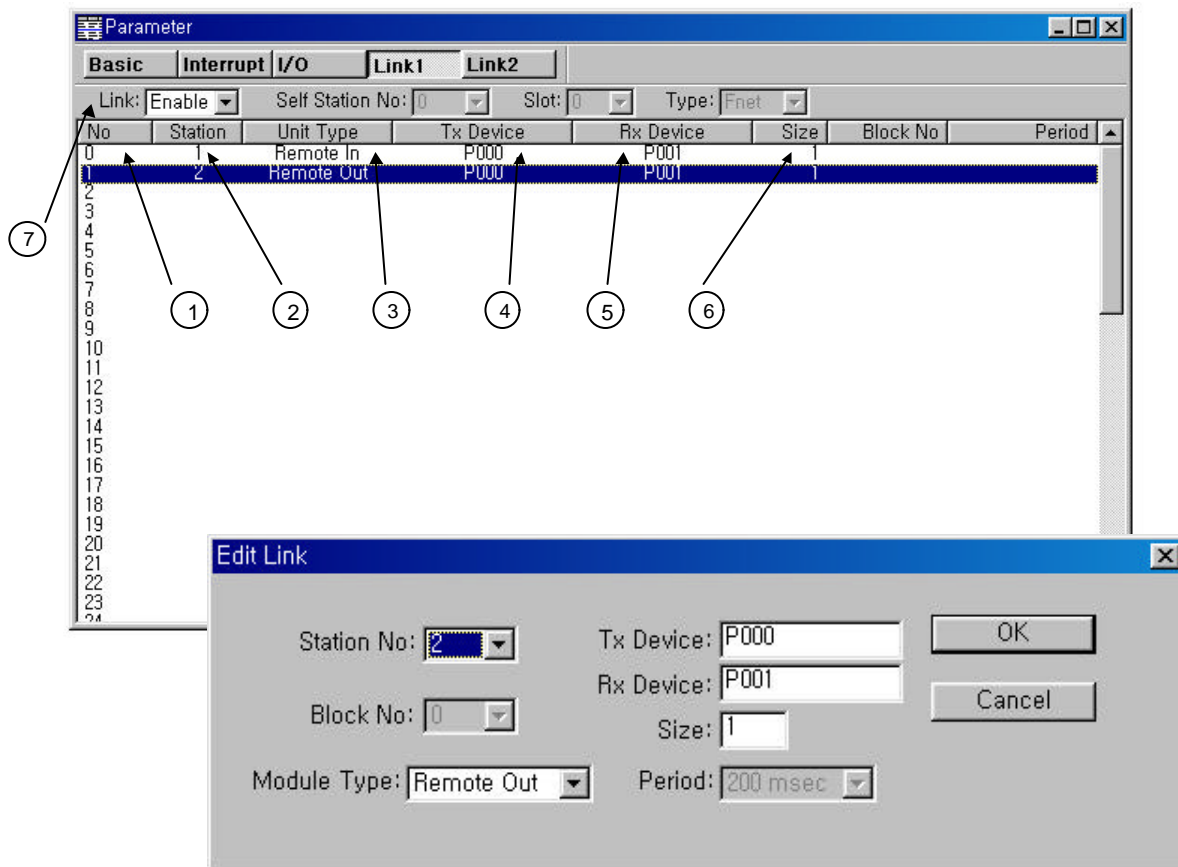

Number of data access block : Max. 64 blocks can be established.

Station number : It can be set as 0 ~ 31.

Unit(module) type : Set the communication direction. (send or receive)

Tx Device : Set the source device. If the unit type is remote in, the Tx device is the device of master station. Otherwise, it is the device of slave station.

Rx Device : Set the destination device. If the unit type is remote in, the Rx device is the device of slave station. Otherwise, it is the device of master station.

Size : Set how many words will be transmitted. (range : 0 ~ 60)

Link : Enable / disable the communication

14.7 Communication status flag

The D4400 ~ D4454 (55 words) are reserved for special register and they contain the error code, error count, and error information.

14.7.1 Error code (D4400 ~ D4415)

The error code of all stations (32 stations) are stored in the D4400 ~ D4415 (16 words). Each error code occupies 1 byte, and 1 word contains 2 error codes. See the chapter 13.8 for the detail information.

Station number	Device	Station number	Device	Remark
0, 1	D4400	16, 17	D4408	Odd number : upper byte
2, 3	D4401	18, 19	D4409	
4, 5	D4402	20, 21	D4410	
6, 7	D4403	22, 23	D4411	
8, 9	D4404	24, 25	D4412	Even number : lower byte
10, 11	D4405	26, 27	D4413	
12, 13	D4406	28, 29	D4414	
14, 15	D4407	30, 31	D4415	

14.7.2 Error count (D4416 ~ D4431)

The CPU has a error counter that counts how many times error occur in each station number. The error count is stores at the special device (D area) as following table.

Station number	Device	Station number	Device	Remark
0, 1	D4416	16, 17	D4424	Odd number : upper byte
2, 3	D4417	18, 19	D4425	
4, 5	D4418	20, 21	D4426	
6, 7	D4419	22, 23	D4427	
8, 9	D4420	24, 25	D4428	Even number : lower byte
10, 11	D4421	26, 27	D4429	
12, 13	D4422	28, 29	D4430	
14, 15	D4423	30, 31	D4431	

14.7.5 Transmission period (D4449 ~ D4454)

The maximum, minimum, and previous period time of the first parameter setting is stored in the D4449 ~ D4454. The period time means the interval from the start of previous transmission to the start of current transmission.

Item	Device area
Maximum	D4449 ~ D4450
Minimum	D4451 ~ D4452
Previous	D4453 ~ D4454

14.8 Monitoring the communication status

User can monitor the RS-422/485 communication status with the high speed link 1 monitoring window of KGL-WIN. (See the below figure) If the CPU type is not B type, the high speed link 1 monitoring window shows the Fnet high speed link information.

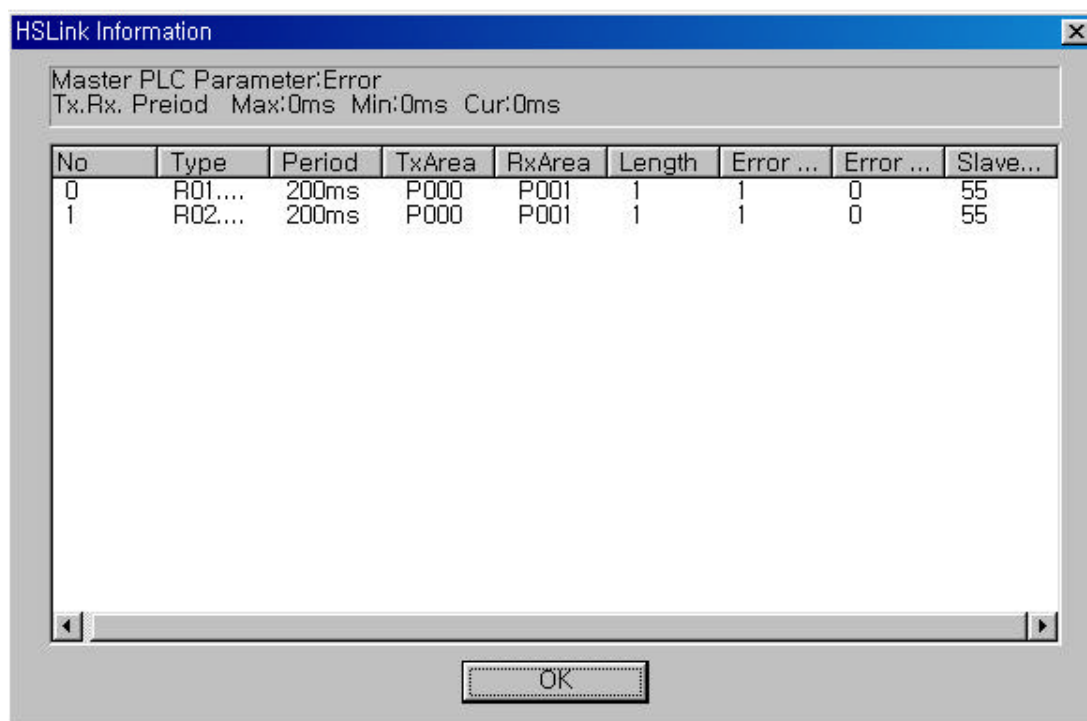

Chapter 15 The PID function of K200S

15	The PID function of K200S	15-1
15.1	Introduction.....	15-1
15.2	Control actions	15-2
15.2.1	Proportional operation (P operation)	15-2
15.2.2	Integral operation (I action)	15-4
15.2.3	Derivative operation (D action)	15-6
15.2.4	PID action.....	15-7
15.2.5	Forward / reverse action.....	15-8
15.2.6	Reference value	15-9
15.2.7	Integral windup.....	15-10
15.3	Realization of PID control on the PLC	15-13
15.3.1	P control	15-13
15.3.2	I control	15-13
15.3.3	D control	15-14
15.3.4	Pseudo code of PID control	15-14
15.4	PID control instructions.....	15-15
15.4.1	PIDCAL.....	15-15
15.4.2	PIDTUN (PID auto tuning)	15-19
15.4.3	Error code list	15-21
15.5	Example of programming	15-23
15.5.1	System configuration.....	15-23
15.5.2	Initial setting	15-23
15.5.3	Program description	15-24
15.5.4	Example program for PIDCAL instruction	15-25
15.5.5	Example program for PIDCAL and PIDTUN instructions	15-26

15 The PID function of K200S

15.1 Introduction

This chapter provides information about the builtin PID (Proportional Integral Differential) control function of K200S B and C type CPU module (K3P-07BS and K3P-07CS). The K200S series does not have separated PID module like K300S and K1000S series, but the PID function is integrated into the CPU module B and C type.

The PID control means a control action in order to keep the object at a set value (SV). It compares the SV with a sensor measured value (PV : Present value) and when a difference between SV and PV (E : the deviation) is detected, the controller output the manipulate value (MV) to the actuator to eliminate the difference. The PID control consists of three control actions that are proportional (P), integral (I), and differential (D).

The characteristics of the PID function of K200S is as following;

- the PID function is integrated into the CPU module. Therefore, all PID control action can be performed with sequence program without any separated PID module.
- forward / reverse operations are available.
- P operation, PI operation, PID operation and On/Off operation can be selected easily.
- the manual output (the user-defined forced output) is available.
- by proper parameter setting, it can keep stable operation regardless of external disturbance.
- the operation scan time (the interval that PID controller gets a sampling data from a ctuator) is changeable for optimizing the system characteristics.

15.2 Control actions

15.2.1 Proportional operation (P operation)

- 1) P action means a control action that obtain a manipulate value which is proportional to the deviation (E: the difference between SV and PV)
- 2) The deviation (E) is obtained by multiplying a reference value to the actual difference between SV and PV. It prevents the deviation value from a sudden change or alteration caused by external disturbance. The formula of deviation is as following;

$$MV = Kp \times [b \times SV - PV]$$

- Kp : proportional constant (gain)
 b : reference value
 SV : set value
 PV : present value

- 3) IF the Kp is too large, the PV reaches to the SV swiftly, but it may cause a bad effect like oscillations shown in the Fig. 15.2
- 4) If the Kp is too small, oscillation will not occur. However, the PV reaches to the SV slowly and an offset may appear between PV and SV shown in the Fig. 15.3
- 5) The manipulation value (MV) varies from 0 to 40,000. User can define the maximum value of MV (MV_MAX) and the minimum value (MV_MIN) within the range 0 ~ 40,000.
- 6) When an offset remains after the system is stabilized, the PV can be reached to the SV by adding a certain value. This value is called as 'Bias', and user can define the bias value in sequence program.

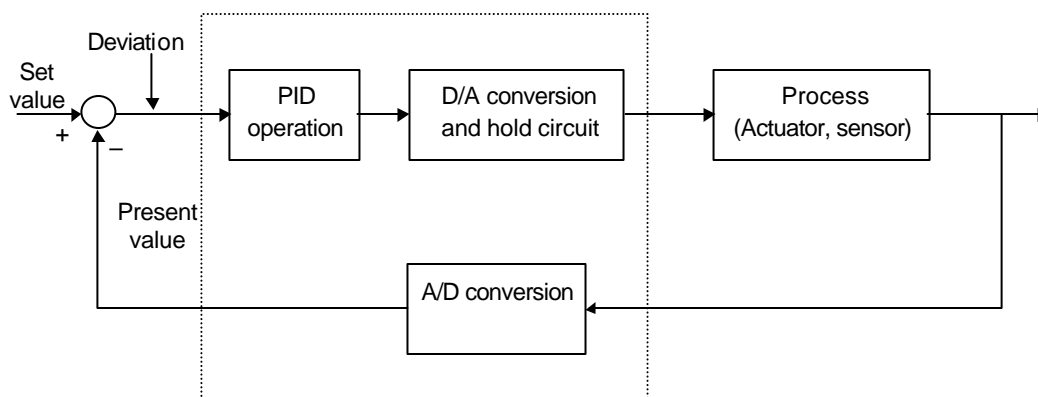

Fig. 15.1 The block diagram of PID control system

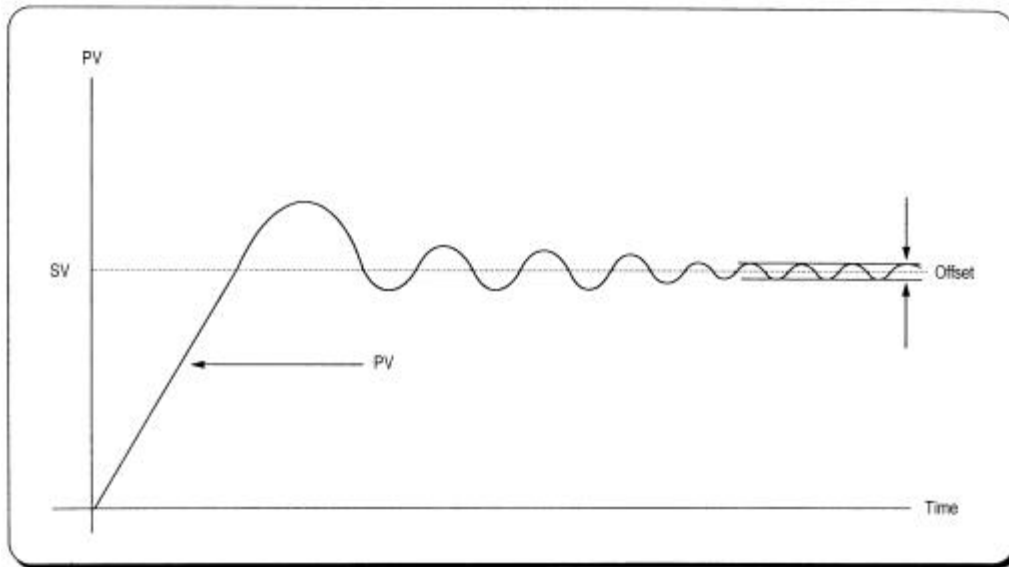

Fig. 15.2 When the proportional constant (K_p) is large

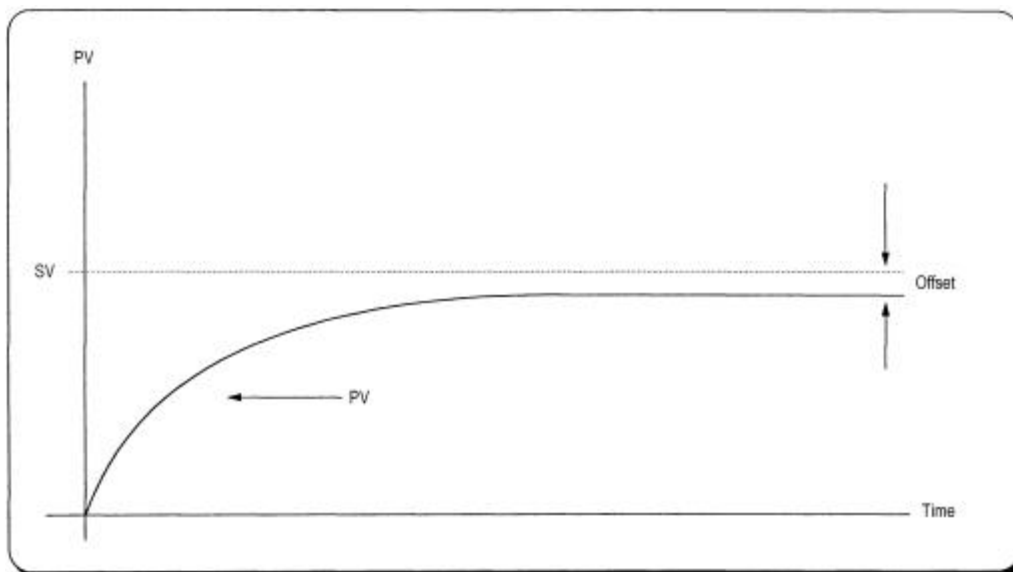

Fig. 15.3 When the proportional constant (K_p) is small

15.2.2 Integral operation (I action)

- 1) With integral operation, the manipulate value (MV) is increased or decreased continuously in accordance time in order to eliminate the deviation between the SV and PV. When the deviation is very small, the proportional operation can not produce a proper manipulate value and an offset remains between PV and SV. In other hand, the integral operation can eliminate the offset value even the deviation is very small.
- 2) The period of the time from when the deviation has occurred in I action to when the MV of I action become that of P action is called integration time and represented as K_i .
- 3) Integral action when a constant deviation has occurred is shown as the following Fig. 15.4.

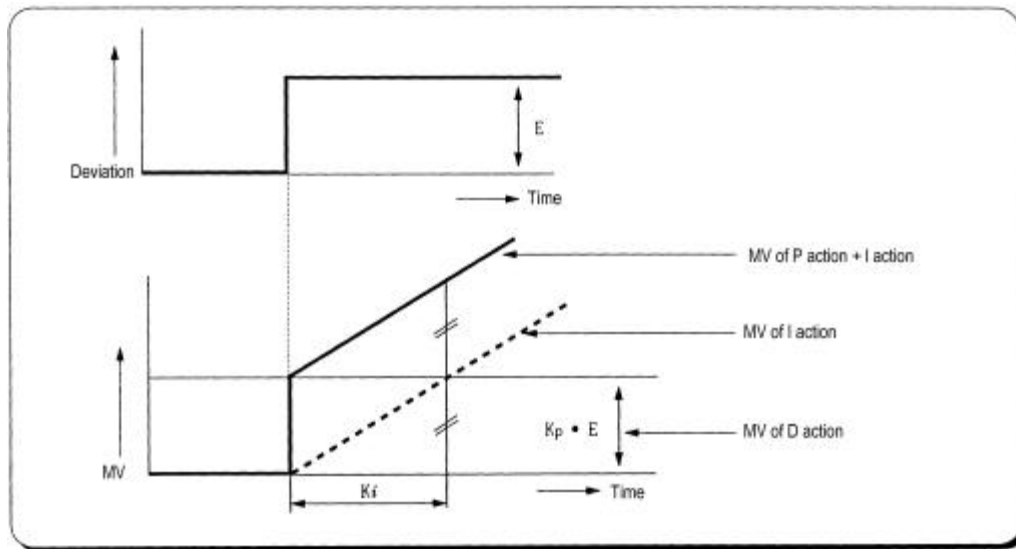

Fig. 15.4 The integral action with constant deviation

- 4) The expression of I action is as following;

$$MV = \frac{K_p}{T_i} \int E dt$$

As shown in the expression, integral action can be made stronger or weaker by adjusting integration time (K_i) in I action.

That is, the more integration time (the longer integration time) as shown in Fig. 15.5, the less quantity added to or subtracted from the MV and the longer time is needed to make PV reached the SV.

As shown in Fig. 15.6, when the integration time given is short the PC will approach the SV in short time since the quantity added or subtracted become increased. However, if the integration time is too short, a oscillation may occur. Therefore, the proper P and I value is requested for stability of control system.

- 5) Integral action is used in either PI action in which P action combines with I action or PID action in which P and D actions combines with I action.

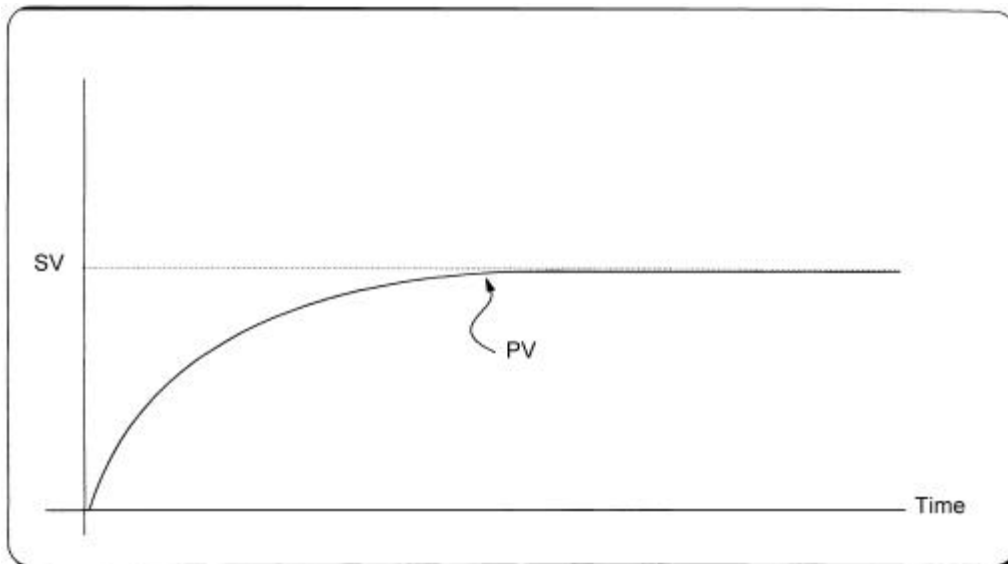

Figure 15.5 The system response when a long integration time given

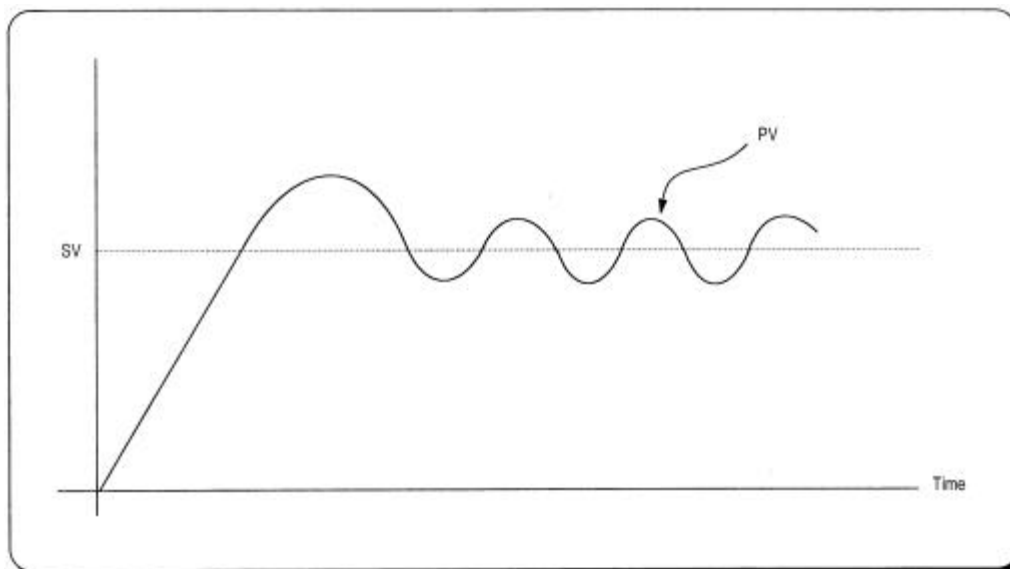

Fig. 15. 6 The system response when a short integration time given

15.2.3 Derivative operation (D action)

- 1) When a deviation occurs due to alteration of SV or external disturbances, D action restrains the changes of the deviation by producing MV which is proportional with the change velocity (a velocity whose deviation changes at a constant interval) in order to eliminate the deviation.
- D action gives quick response to control action and has an effect to reduce swiftly the deviation by applying a large control action (in the direction that the deviation will be eliminated) at the earlier time that the deviation occurs.
- D action can prevent the large changes of control object due to external conditions.
- 2) The period of time from when the deviation has occurred to when the MV of D action become the MV of P action is called derivative time and represented as K_d .
- 3) The D action when a constant deviation occurs is shown as Fig. 15.7.

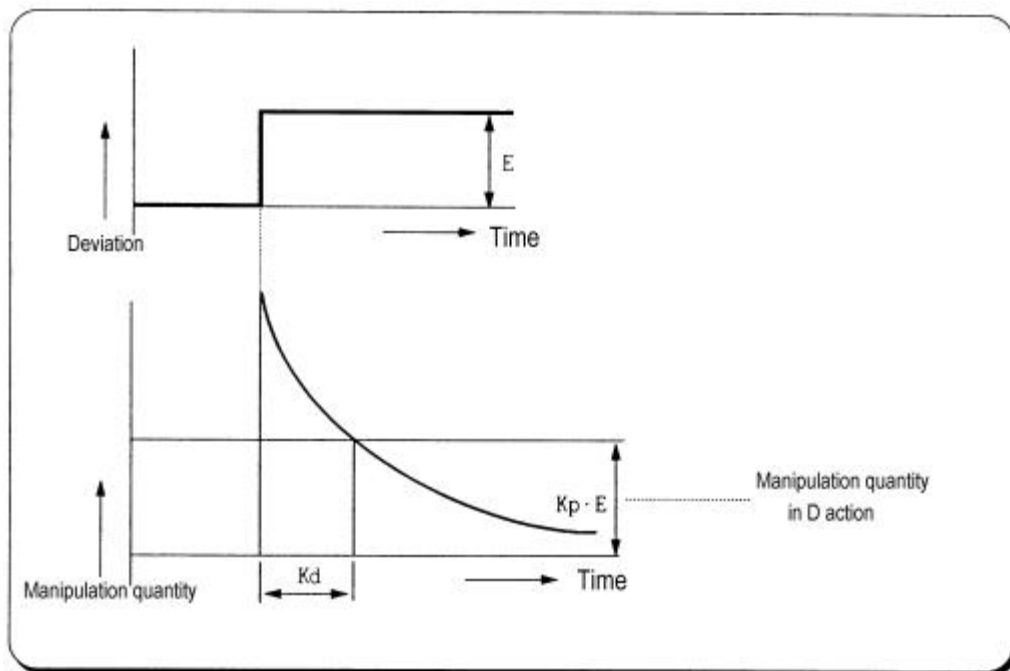

Figure 15.7 Derivative action with a constant deviation

- 4) The expression of D action is as following ;

$$MV = K_p \times T_d \frac{dE}{dt}$$

- 5) Derivative action is used only in PID action in which P and I actions combine with D action.

15.2.4 PID action

- 1) PID action controls the control object with the manipulation quantity produced by PID action (P + I + D).
- 2) PID action with a constant deviation is shown as the following figure 15.8.

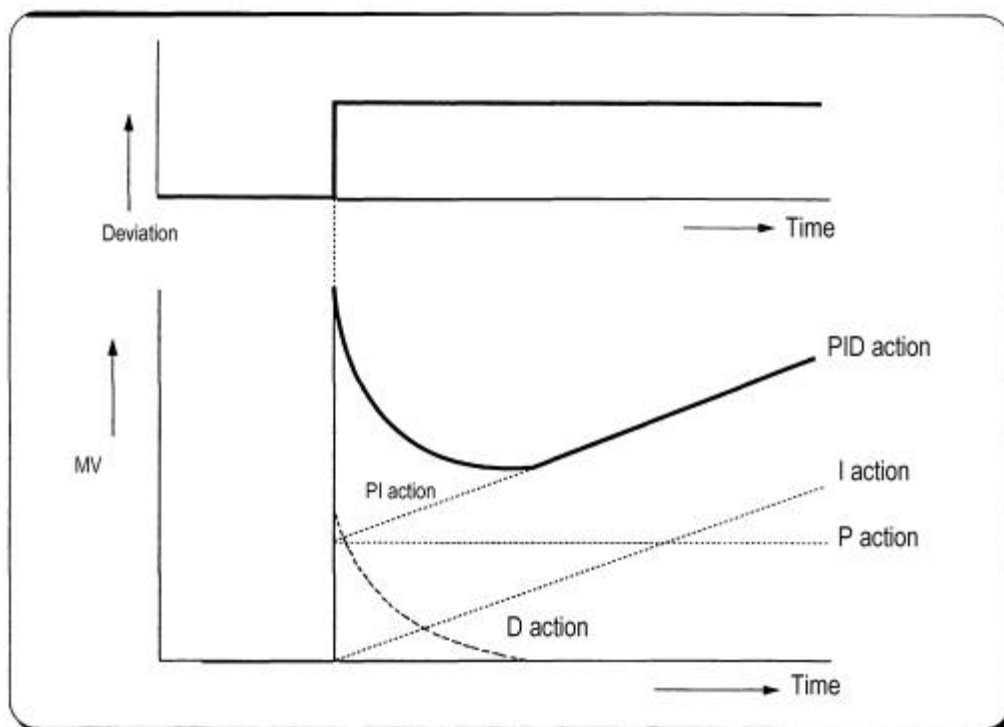

Fig. 15.8 PID action with a constant deviation

15.2.5 Forward / reverse action

- 1) PID control has two kinds of action, forward action and reverse action. The forward action makes the PV reaches to SV by outputting a positive MV when the PV is less than SV.
- 2) A diagram is which forward and reverse actions are drawn using MV, PV, and SV is shown as figure 15.9.

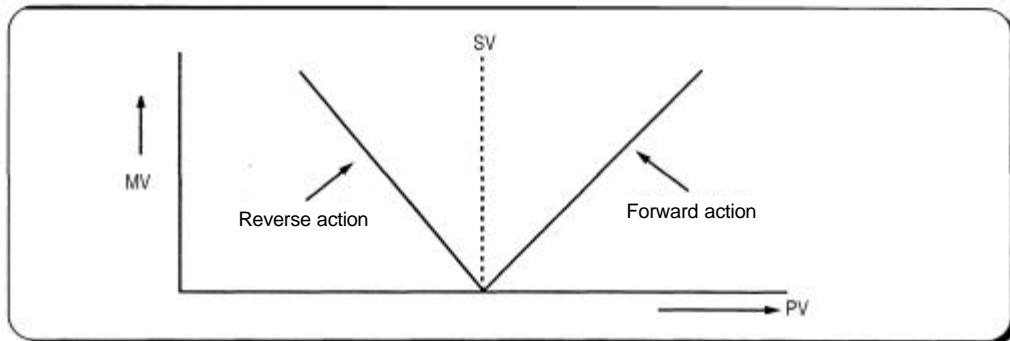

Fig. 15.9 MV of forward / reverse action

- 3) The figure 2.10 shows examples of process control by forward and reverse actions, respectively.

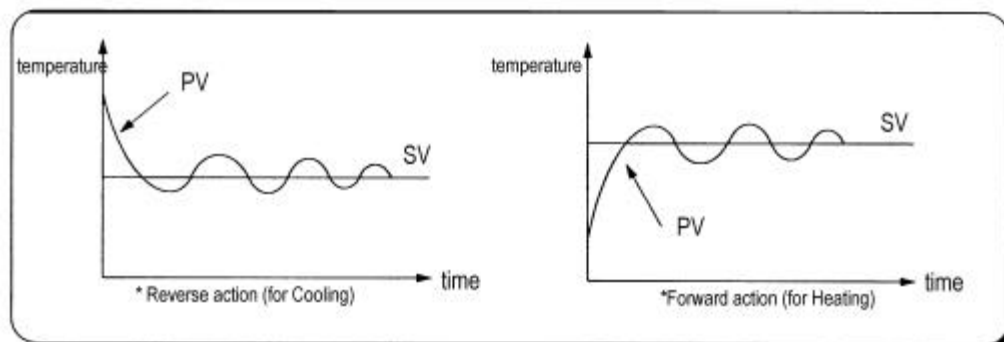

Fig. 15.10 PV of forward / reverse action

15.2.6 Reference value

In general feedback control system shown as the figure 15.11, the deviation value is obtained by the difference of PV and SV. P, I, and D operations are performed based on this deviation value. However, each of P, I, and D operations use different deviation values according to the characteristics of each control actions. The expression of PID control is as following;

$$MV = K \left[Ep + \frac{1}{Ti} \int_0^t Ei(s) ds + Td \frac{dEd}{dt} \right]$$

- MV : Manipulate value
- K : Proportional gain
- Ti : Integral time
- Td : Derivative time
- Ep : Deviation value for proportional action
- Ei : Deviation value for integral action
- Ed : Deviation value for derivative action

The deviation values of P, I, and D action is described as following equations;

$$Ep = b \times SV - PV$$

$$Ei = SV - PV$$

$$Ed = -PV$$

The b in the first equation is called as reference value. It can be varied according to the load disturbance or measurement noise.

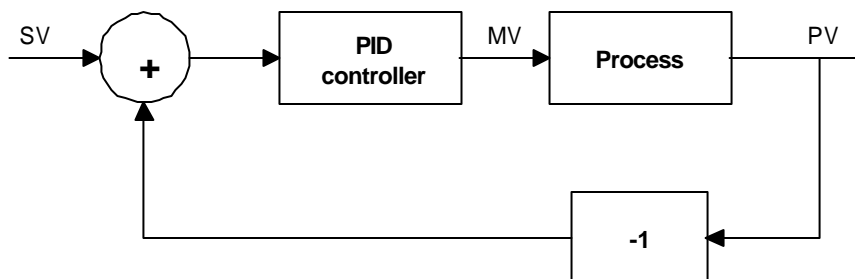

Fig. 15.11 Diagram of simple feedback control system

The figure 15.12 shows the variation of PV according to the several different reference values (b). As shown in the figure 15.12, the small reference value produces small deviation value, and it makes the control system response be slow.

In general, control system is required to be adaptable to various external or internal changes. Especially, it should shows a stable transit response with the sudden change of the SV to be robust to load disturbance and/or measurement noise.

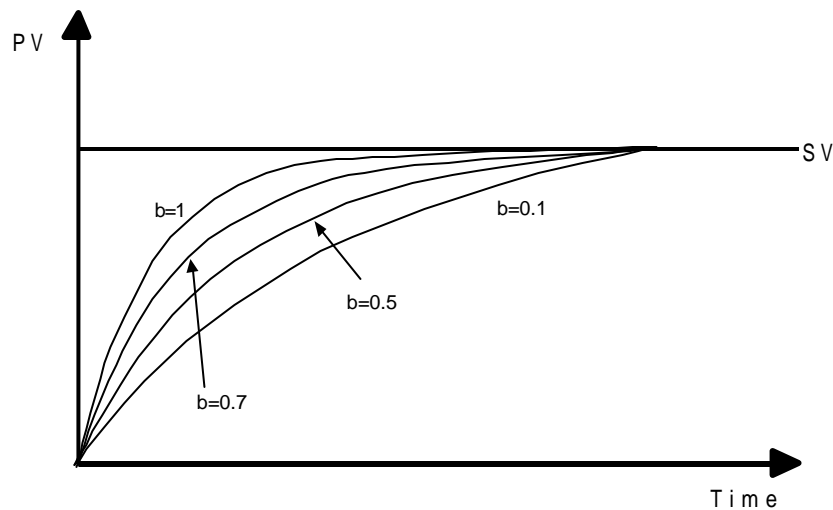

Fig. 15.12 The PI control with several reference values

15.2.7 Integral windup

All devices to be controlled, actuator, has limitation of operation. For example, the motor has speed limit, the valve can not flow over the maximum value. When the control system has wide PV range, the PV can be over the maximum output value of actuator. At this time, the actuator keeps the maximum output regardless the change of PV while the PV is over the maximum output value of actuator. It can shorten the lifetime of actuator.

When the I control action is used, the deviation term is integrated continuously. It makes the output of I control action very large, especially when the response characteristic of system is slow.

This situation that the output of actuator is saturated, is called as 'windup'. It takes a long time that the actuator returns to normal operating state after the windup was occurred.

The figure 15.13 shows the PV and MV of PI control system when the windup occurs. As shown as the figure 15.13, the actuator is saturated because of the large initial deviation. The integral term increase until the PV reaches to the SV (deviation = 0), and then start to decrease while the PC is larger than SV (deviation < 0). However, the MV keeps the saturated status until the integral term is small enough to cancel the windup of actuator. As the result of the windup, the actuator will output positive value for a while after the PV reached to the SV, and the system show a large overshoot. A large initial deviation, load disturbance, or mis-operation can cause windup of actuator.

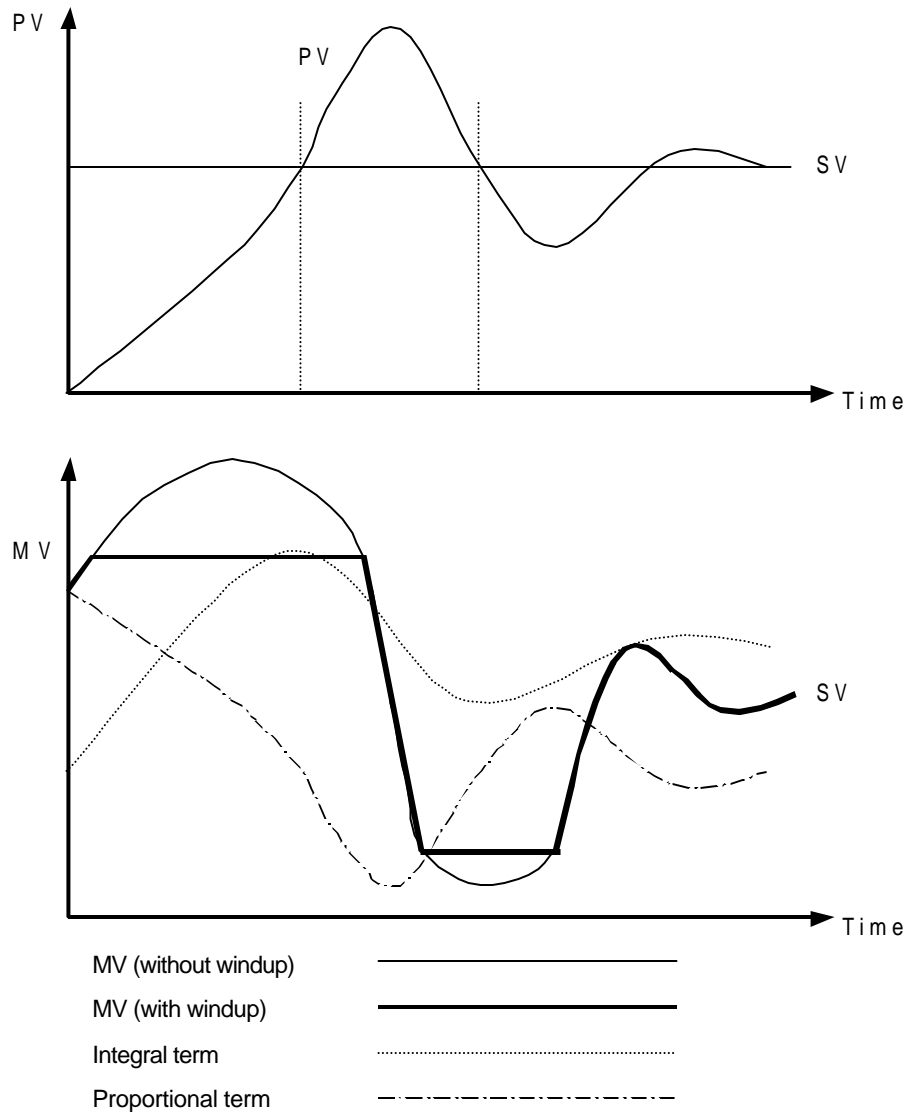

Fig. 15.13 An example of integral windup

There are several methods to avoid the windup of actuator. The most popular two methods are adding another feedback system to actuator, and modeling the actuator. The figure 15.14 shows the block diagram of the anti-windup control system using the model of actuator.

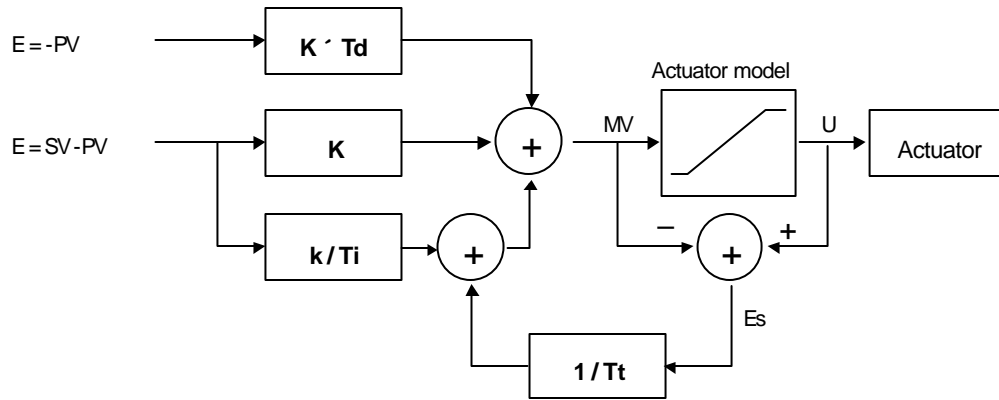

Fig. 15.14 The block diagram of anti-windup control system

As shown in the figure 15.14, the anti-windup system feedback the multiplication of gain ($1/T_t$) and E_s to the input of integral term. The E_s is obtained as the difference value between actuator output (U) and manipulation value of PID controller (MV). The T_t of the feedback gain is tracking time constant, and it is in inverse proportion with the resetting speed of integral term. Smaller T_t will cancel the windup of actuator faster, but too small T_t can cause anti-windup operation even in derivation operation. The figure 15.15 shows several T_t value and PV in the PI control system.

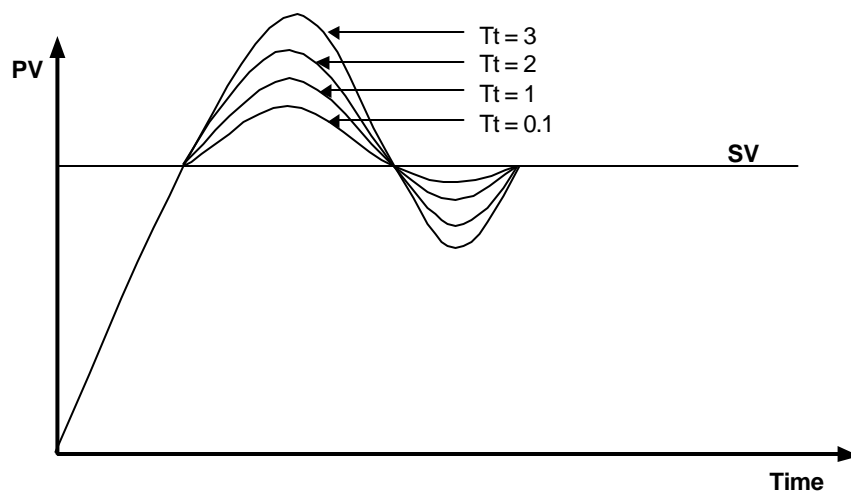

Fig. 15.15 The PV output characteristics with different T_t values

15.3 Realization of PID control on the PLC

In this chapter, it will be described that how to get the discrete formula of the P, I, and D terms. Then, the pseudo code of PIF control will be introduced.

15.3.1 P control

The discrete formula of P control is as following;

$$P(n) = K[b \times SV(n) - PV(n)]$$

n : sampling number

K : proportional gain constant

b : reference value

SV : set value

PV : present value

15.3.2 I control

The continuous formula of I control is as following;

$$I(t) = \frac{K}{T_i} \int_0^t e(s) ds$$

I(t) : integral term

K : proportional gain constant

T_i : integral time

e(s) : deviation value

By deviation about t, we can obtain;

$$\frac{dI}{dt} = \frac{K}{T_i} e$$

e = (SV - PV) : deviation value

The digitized formula is as following;

$$\frac{I(n+1) - I(n)}{h} = \frac{K}{T_i} e(n)$$

h : sampling period

$$I(n+1) = I(n) + \frac{Kh}{T_i} e(n)$$

15.3.3 D control

The continuous formula of derivative term is as following;

$$\frac{Td}{N} \times \frac{d}{dt} D + D = -KTd \frac{dy}{dt}$$

N : high frequency noise depression ration

y : the object to be controlled (PV)

The digitized formula is as following (Use Tustin approximation method)

$$D(n) = \frac{2Td - hN}{2Td + hN} D(n-1) - \frac{2KTdN}{2Td + hN} [y(n) - y(n-1)]$$

15.3.4 Pseudo code of PID control

The pseudo code of PID control is as following;

Step 1 : Get constants that are used for PID operation

$$Bi = K \times \frac{h}{Ti} \quad : \text{integral gain}$$

$$Ad = \frac{(2 \times Td - N \times h)}{(2 \times Td + N \times h)} \quad : \text{derivation gain}$$

$$Bd = \frac{(2 \times K \times N \times Td)}{(2 \times Td + N \times h)}$$

$$A0 = \frac{h}{Tt} \quad : \text{anti-windup gain}$$

Step 2 : Read SV and PV value

$$PV = \text{adin}(\text{ch1})$$

Step 3: Calculate the proportional term.

$$P = K \times (b \times SV - PV)$$

Step 4 : Update the derivative term. (initial value of D = 0)

$$D = As \times D - Bd \times (PV - PV_old)$$

Step 5 : Calculate the MV. (initial value of I = 0)

$$MV = P + I + D$$

Step 6 : Check the actuator is saturated or not.

$$U = \text{sat}(MV, U_low, U_high)$$

Step 7 : Output the MV value to the D/A module

Step 8 : Update the integral term.

$$I = I + bi \times (SV - PV) + A0 \times (U - MV)$$

Step 9 : Update the PV_old value.

$$PV_old = PV$$

15.4 PID control instructions

The MASTER-K series has 2 instructions for PID control as following table.

No	Instruction	Description
1	PIDCAL	Execute PID operation
2	PIDTUN	Execute auto tuning operation

Remark

The PID instructions (PIDCAL, PIDTUN) are available only K200S B and C type. (K3P-07BS and K3P-07CS) With the K200S A type (K3P-07AS), these instructions are ignored.

15.4.1 PIDCAL

The PIDCAL instruction executes PID operation with given parameters, and output the result to the specific devices. It occupies 37 words for its execution, so please be careful that other instruction do not use the devices that are using for PID operation. To execute PIDCAL instruction, all necessary parameters should be input at the specified devices.

The following table shows the device map for PIDCAL instruction.

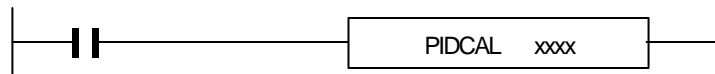

xxxx : The start address of PID operation area (37 words)

Device offset	Name	Description	Range
+0	S_TIME	Operation scan time	1 ~ 100
+1	MVMAN	Manual operation value data	0 ~ 4000
+2	MV_MIN	Minimum value of manipulation value	0 ~ 4000
+3	MV_MAX	Maximum value of manipulation value	0 ~ 4000
+4	N	High frequency noise depression ratio	1 ~ 10
+5	TT	Tracking time constant	1 ~ 1000
+6	REF	Reference value	1 ~ 10
+7	D_TIME	The time constant of derivation operation (Td)	0 ~ 20000
+8	I_TIME	The time constant of integral operation (Ti)	0 ~ 20000
+9	P_GAIN	The proportional gain constant (K)	0 ~ 10000
+10	EN_D	Enable / disable the derivative operation	0 or 1

(Continued)

Device offset	Name	Description	Range
+ 11	EN_I	Enable / disable the integral operation	0 or 1
+ 12	EN_P	Enable / disable the proportional operation	0 or 1
+ 13	BIAS	The bias value for offset compensation	0 ~ 4000
+ 14	PV	The present value	
+ 15	SV	The set value data	0 ~ 4000
+ 16	F/R	Select forward or reverse operation	0 or 1
+ 17	MAN	Enable / disable manual operation	0 or 1
+ 18	STAT	Shows an error code when error occurs	
+ 19	MV	The manipulation value (MV) output	
+ 20	ERR	The deviation between PV and SV	
+ 21	P_VAL (LOW)	Reserved for internal calculation	
+ 22	P_VAL (HIGH)		
+ 23	I_VAL (LOW)		
+ 24	I_VAL (HIGH)		
+ 25	P_VAL (LOW)		
+ 26	P_VAL (HIGH)		
+ 27	Bi	System use only	
+ 28	Ad		
+ 29	Bd		
+ 30	AO		
+ 31	PV_OLD		
+ 32	ACTUATOR_OUT		
+ 33	REAL_MV (LOW)		
+ 34	REAL_MV (HIGH)		
+ 35	CORRUPT/STAGE		
+ 36	TEMP_PV		

1) S_TIME

The scan time in PID operation means the interval of sampling the present value (PV). In general, the PID operation shows best performance when the S_TIME is synchronized with external enable input. (The input condition of PIDCAL instruction)

The range of S_TIME is 0.1 ~ 10 seconds. However, when input S_TIME data into PLC device, it is scaled up 10 times for more precise setting. Therefore, the actual range of input data is 1 ~ 100.

2) MVMAN

In this area, the data that are output when the manual operation is enabled. When the MAN is set as 1, the PIDCAL instruction output the MVMAN to MV regardless the PID operation result. The setting range is 0 ~ 4000.

3) MV_MIN/MV_MAX

User can set limit point on the manipulation value as MV_MIN(the minimum value) and MV_MAX(the maximum value).

4) N (high frequency noise depression ratio)

This parameter is used for derivative control operation, and shows the ratio of high frequency noise depression. If there is a lot of high frequency noise in the control system, select the N value as higher value. Otherwise, leave the N parameter as 1. The range of N is 0 ~ 10 and it is not scaled up, so input the designated value directly.

5) TT (Tracking time constant)

This parameter is used to cancel anti-windup operation. The range of TT is 0.01 ~ 10 and the actual input range that are 100 times scaled up is 0 ~ 1000.

6) REF (Reference value)

The REF may be useful parameter according to the control system type, especially velocity, pressure, or flux control system. The range of REF input is 0.1 ~ 1, but it is 10 times scaled up when input REF into the PLC device (the actual range is 0 ~ 10).

7) D_TIME (Derivation time constant) / I_TIME (Integral time constant)

The range of D_TIME and I_TIME is 0.0 ~ 2000.0. However, the 10 times scaled up value is used when input data into the PLC device. Therefore, the actual data range is 0 ~ 20000.

8) P_GAIN (Proportional gain constant)

The range of P_GAIN is 0.00 ~ 100.00. Because the K200S CPU can not handle floating point number, it should be scaled up 100 times when input P_GAIN into PLC device. Therefore, the actual data range of P_GAIN is 0 ~ 10000.

9) EN_D / EN_I / EN_P (Control mode)

The built-in PID controller of K200S has four control modes as following table. The control mode can be set by EN_D, EN_I, and EN_P words.

No	EN_P	EN_I	EN_D	Control mode
1	1	0	0	P operation
2	1	1	0	PI operation
3	1	1	1	PID operation
4	0	0	0	On/off operation

0 : Disable

1 : Enable

Remark

The other control modes other than P, PI, PID, and On/off operation are not allowed. For example, PD or I operation is not available.

10) BIAS

The BIAS data is used for the compensation of offset in the proportional control. The range is 0 ~ 4000.

11) SV (Set value)

SV (setting value : the designated value) and PV (process value : present value) of K200S PID operation have the range 0 ~ 4000. The range is set with the consideration of the resolution of A/D and D/A module of K200S series (12 bits) and offset value.

12) F/R (Forward / reverse operation)

The operation mode (forward or reverse) can be set with F/R word. If the value of F/R is 0, the PIDCAL instruction performs forward operation. If the F/R is 1, reverse operation is performed.

13) STAT

The PIDCAL instruction output a relevant error code when an error occurs during PID operation. See the chapter 15.4.3 error code list for details

14) MV (Manipulation value)

The result of PID calculation is output to this word.

15.4.2 PIDTUN (PID auto tuning)

The PIDAUT instruction is used for getting PID parameters automatically. It calculates optimal K (proportional gain constant), Ti (Integral time constant), and Td (Derivative time constant), and returns the result. It occupies 19 words for its execution, so make sure the other instructions use those devices.

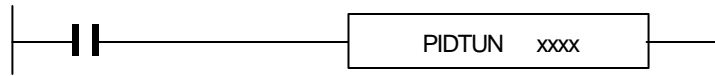

xxxx : The start address of PID operation area (19 words)

Device offset	Name	Description	Range
+0	S_TIME	Operation scan time	1 ~ 100
+1	PV	Present value of control object	
+2	SV	Set value	0 ~ 4000
+3	RIPPLE	Select the wave that are used for PID parameter calculation	0 or 1
+4	STAT	Error code	
+5	MV	Manipulation value of current loop	
+6	P	The output of calculated K	
+7	I	The output of calculated Ti	
+8	D	The output of calculated Td	
+9	PV_OLD	System use only	
+10	LIMIT		
+11	ULTIMATE_TIME		
+12	MAX_amplitude		
+13	MIN_amplitude		
+14	STAGE		
+15	Region / Corrupt		
+16	Temp_PV		
+17	Amplitude		
+18	Kc		

1) S_TIME (Scan time)

The scan time in PID operation means the interval of sampling the present value (PV). In general, the PID operation shows best performance when the S_TIME is synchronized with external enable input. (The input condition of PIDAUT instruction)

The range of S_TIME is 0.1 ~ 10 seconds. However, when input S_TIME data into PLC device, it is scaled up 10 times for more precise setting. Therefore, the actual range of input data is 1 ~ 100.

2) SV (Set value)

SV (setting value : the designated value) and PV (process value : present value) of K200S PID operation have the range 0 ~ 4000. The range is set with the consideration of the resolution of A/D and D/A module of K200S series (12 bits) and offset value. When setting the SV or PV, please be careful convert the analog value of control object (temperature, velocity, etc.) to digital value that are the output of A/D convert module. For example, assume that PID control is used for temperature control with Pt100 (operation range : 0 °C ~ 250 °C), and the goal value is 100 °C. The equivalent digital output of A/D module (voltage output range : 1 ~ 5V) is 1600 if the A/D module outputs 0 (1V) with 0 °C, and 4000(5V) with 250 °C. Therefore, the input of SV should be 1600, not 100.

3) Ripple

The K3P-07BS and K3P-07CS CPU module perform auto-tuning operation based on the frequency response method. PID parameters are obtained by On/Off operation during 1 cycle of PV variation. The RIPPLE parameter shows at which cycle the CPU module will perform auto-tuning operation. If 0 is selected, the CPU will get PID parameters during the first cycle of PV variation. If 1 is selected, the second cycle will be used. (refer figure 15.16 for detailed information) Other choice of RIPPLE parameter is not allowed. In general case, select 1 for proper auto-tuning operation. The On/Off operation will be occur at the 80% of PV value.

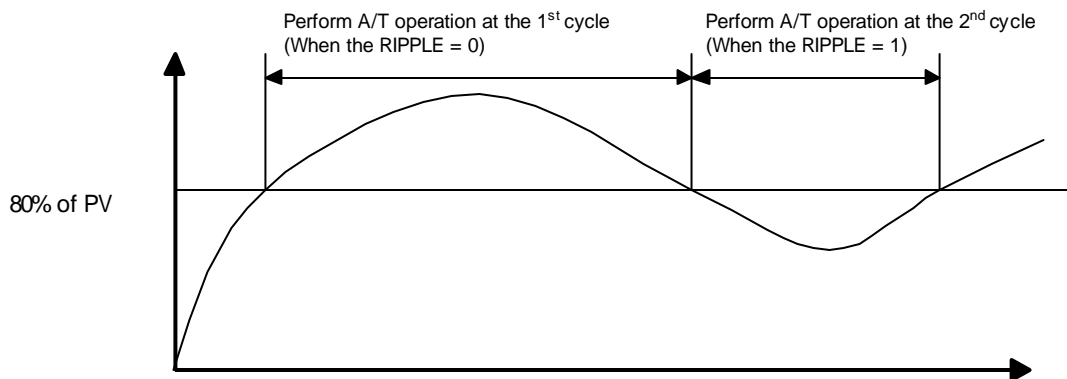

Fig. 15.16 An example of auto-tuning PID parameters

4) STAT

The PIDAUT instruction outputs a relevant error code when an error occurs during PID operation. See the chapter 15.4.3 error code list for details

5) P/I/D

The calculated PID parameters are output to these words.

15.4.3 Error code list

1) PIDCAL instruction

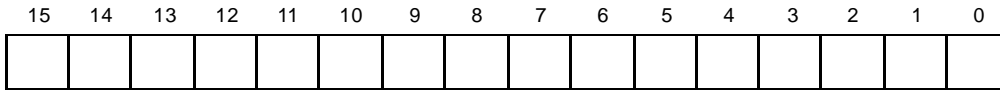

Bit 0 : Done

Turn on when the execution of PIDCAL instruction is completed.

Bit 1 ~ Bit 5 : Not used

Bit 6 : Q_MIN

Turn on when an error is detected with MV_MIN value.

Bit 7 : Q_MAX

Turn on when an error is detected with MV_MAX value.

Bit 8 ~ 15 : Error code (See following table for details)

Error code (Upper byte)	Description	Countermeasure
h00	Normal operation	
h01	SV is out of range	Change the SV within 0 ~ 4000
h02	MVMAN is out of range	Change the MVMAN within 0 ~ 4000
h03	P_GAIN is out of range	Change the P_GAIN within 0 ~ 10000
h04	I_TIME is out of range	Change the I_TIME within 0 ~ 20000
h05	D_TIME is out of range	Change the D_TIME within 0 ~ 20000
h06	S_TIME is out of range	Change the S_TIME within 0 ~ 100
h07	REF is out of range	Change the REF within 0 ~ 10
h08	TT is out of range	Change the TT within 0 ~ 1000
h09	N is out of range	Change the N within 0 ~ 1000
h0A	EN_I and/or EN_D is set as 1 when EN_P is 0	Only P, PI, and PID controls are available with K3P-07BS and K3P-07CS. Please change the setting of EN_P, EN_I, and EN_D by reference to the chapter 15.3.1.
h28	CPU type is mismatched	Replace the CPU module with K3P-07BS (B type) or K3P-07CS (7 seven up).

2) PIDAUT instruction

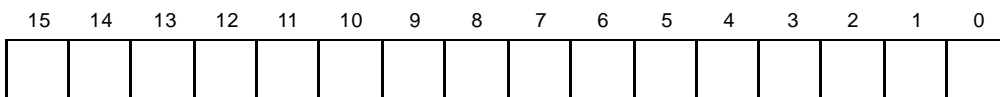

Bit 0 ~ Bit 6 : Not used

Bit 7 : Done

Turns on when the auto-tuning operation is completed.

Bit 8 ~ Bit 15 : Error code (See following table for details)

Error code (Upper byte)	Description	Countermeasure
h00	Normal operation	
h01	SV is out of range	Change the SV within 0 ~ 4000
h02	PV is out of range	It may caused by fault of A/D module. Check the A/D module.
h03	S_TIME is out of range	Change the S_TIME within 0 ~ 100
h28	CPU type is mismatched	Replace the CPU module with K3P-07BS (B type) or K3P-07CS (C type).

15.5 Example of programming

15.5.1 System configuration

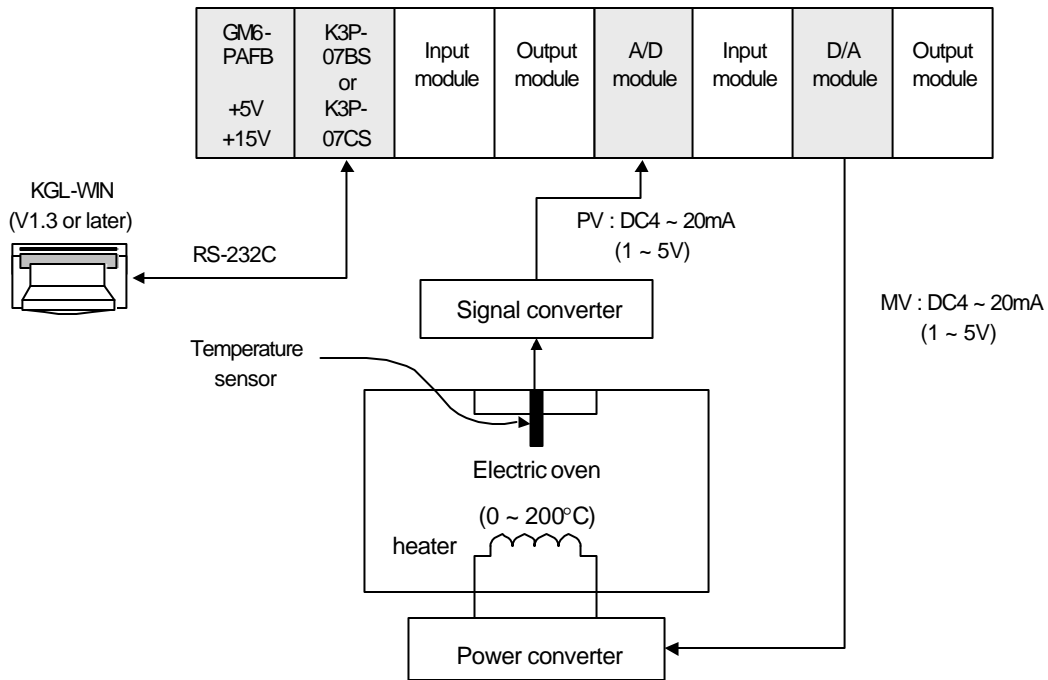

15.5.2 Initial setting

1) PID operation parameters

Auto / Manual operation setting	: Auto
Forward / Reverse operation	: Forward
SV setting	: 1600 (100°C)
BIAS setting	: 0 (If only P control is used, input proper value other 0)
EN_P, EN_I, EN_D setting	: EN_P=1, EN_I=1, EN_D=1 (PID operation)
REF, TT, N	: REF=10, TT=5-, N=1
MV_MAX, MV_MIN, MVMAN	: MV_MAX=4000, MC_MIN=0, MAMAN=2000
S_TIME	: S_TIME=100 (sampling time = 10 seconds)

2) Auto-tuning parameters

PV setting	: 1600 (100°C)
S_TIME	: S_TIME=100 (sampling time = 10 seconds)

- 3) A/D module setting
 - Channel setting : use channel 0
 - Output data type : -48 ~ 4047
 - Input processing : Sampling
- 4) D/A module setting
 - Channel setting : use channel 0

15.5.3 Program description

- 1) Use only PID operation (without auto-tuning function)
 - Convert the measured temperature (0 ~ 250°C) to current signal (4 ~ 20mA), and input the current signal to the channel 0 of A/D module. Then, the A/D module converts the analog signal to digital value (0 ~ 4000)
 - PIDCAL instruction will calculate manipulate value (MV : 0 ~ 4000) based on PID parameter settings (P_GAIN, I_TIME, D_TIME, etc.) and PV from A/D module. Then, the calculated MV is output to the channel 0 of D/A module.
 - D/A module will convert the MV (0 ~ 4000) to analog signal (4 ~ 20mA) and output to the actuator (power converter).
- 2) Use PID operation with auto-tuning function
 - Convert the measured temperature (0 ~ 250°C) to current signal (4 ~ 20mA), and input the current signal to the channel 0 of A/D module. Then, the A/D module converts the analog signal to digital value (0 ~ 4000)
 - The PIDTUN instruction will calculate manipulate value (MV : 0 ~ 4000) based on the SV from user input and PV from A/D module. Simultaneously, the A/T module will calculate P, I and D parameters.
 - The bit 7 of STAT output of PIDTUN instruction will be 1 when the A/T operation is completed. Then, PID module will start operation with PID parameters that are calculated by PIDTUN instruction.
 - D/A module will convert the MV (0 ~ 4000) to analog signal (4 ~ 20mA) and output to the actuator (power converter).

15.5.4 Example program for PIDCAL instruction

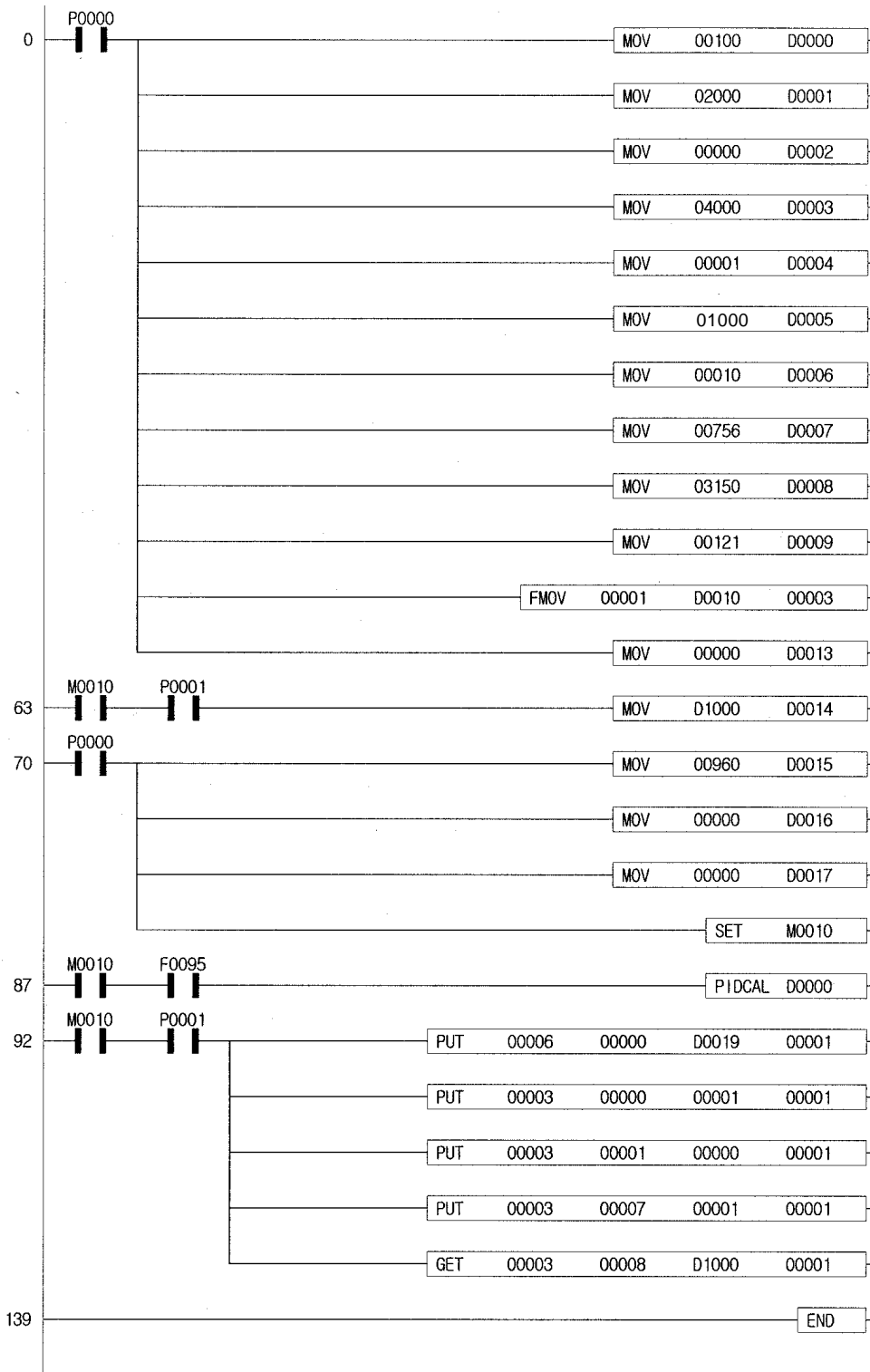

15.5.5 Example program for PIDCAL and PIDTUN instructions

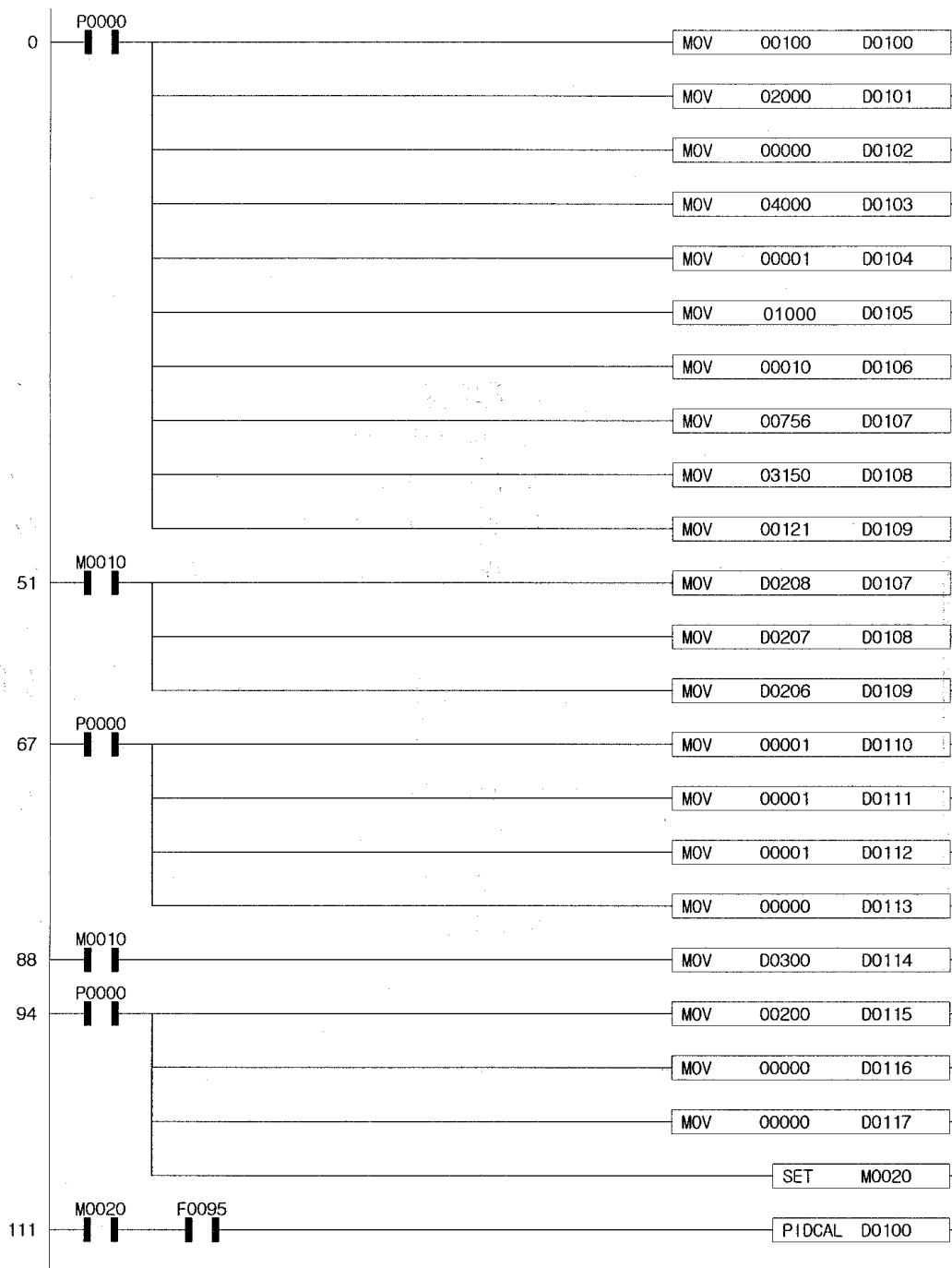

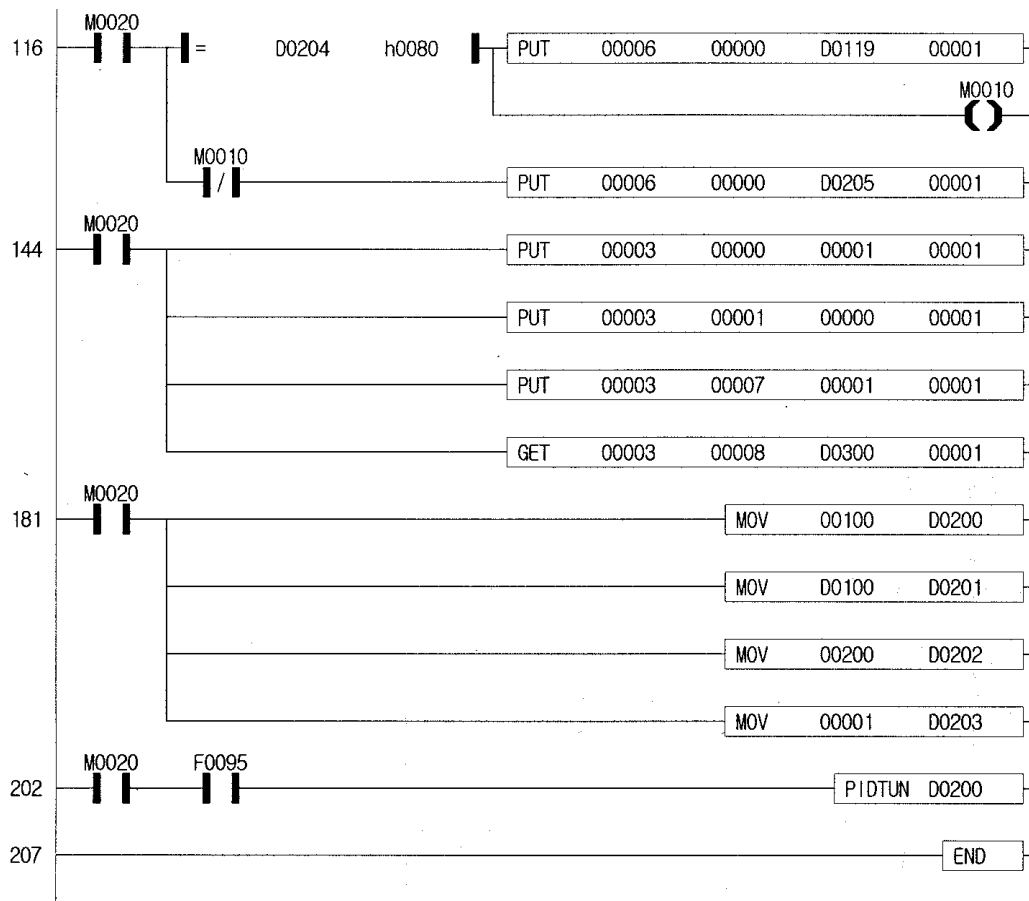

Chapter 16 Built-in high speed counter of K200S

16	Built-in high speed counter of K200S	16-1
16.1	Introduction	16-1
16.2	Performance specifications	16-1
16.3	Input specifications	16-2
16.3.1	Pin-out of input terminal	16-2
16.3.2	Name of terminal	16-2
16.3.3	External interface circuit	16-3
16.4	Wiring	16-4
16.4.1	Wiring instructions	16-4
16.4.2	Wiring examples	16-4
16.5	HSC instruction	16-5
16.5.1	Introduction	16-5
16.5.2	Operation mode (D4999)	16-6
16.6	Example of program	16-7
16.6.1	1-phase operation mode (D4999 = h1010)	16-7
16.6.2	1-phase operation mode (D4999 = h1100)	16-8
16.6.3	2-phase operation mode (D4999 = h2011)	16-9
16.6.4	2-phase operation mode (D4999 = 2012)	16-10
16.6.5	2-phase operation mode (D4999 = h2014)	16-11

16 Built-in high speed counter of K200S

16.1 Introduction

This chapter describes the specification, handling, and programming of built-in high speed counter of K200S C type CPU module (K3P-07CS). The built-in high speed counter of K3P-07CS (Hereafter called HSC) has the following features;

- 1) 3 counter functions as followings
 - 1-phase up / down counter : Up / down is selected by user program
 - 1-phase up / down counter : Up / down is selected by external B phase input
 - 2-phase up / down counter : Up / down is automatically selected by the phase difference between phase A and B.
- 2) Multiplication (1, 2, or 4) with 2-phase counter
 - 2-phase pulse input multiplied by one : Counts the pulse at the leading edge of phase A.
 - 2-phase pulse input multiplied by two : Counts the pulse at the leading / falling edge of phase A.
 - 2-phase pulse input multiplied by four : Counts the pulse at the leading / falling edge of phase A and B

16.2 Performance specifications

Items		Specifications
Input signal	Types	Phase A, Phase B, Preset
	Rated level	24VDC (13mA)
	Signal type	Voltage input
Counting range		0 ~ 16,777,215 (Binary 24 bits)
Max. counting speed		50k pps
Up / Down selection	1-phase	Sequence program or B-phase input
	2-phase	Auto-select by phase difference of phase A and B
Multiplication		1, 2, or 4
Preset input		Sequence program or external preset input

16.3 Input specifications

16.3.1 Run-out of input terminal

Items		Specifications
A/B phase	Rated input	24VDC (13mA)
	On voltage	14VDC or higher
	Off voltage	2.5VDC or lower
Preset input	Rated input	24VDC (10mA)
	On voltage	19VDC or higher
	Off voltage	6V or lower
	On delay time	Less than 1.5ms
	Off delay time	Less than 2ms

16.3.2 Name of terminal

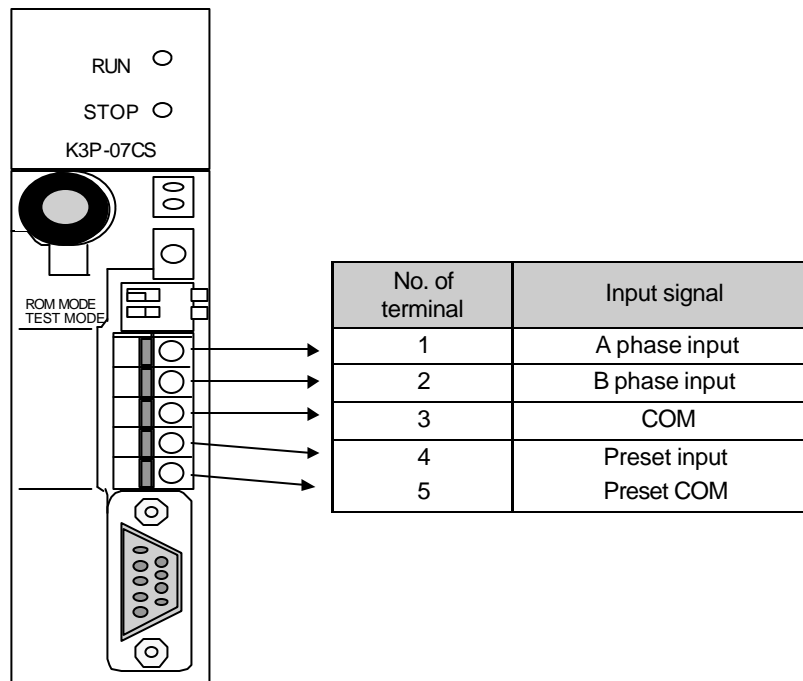

16.3.3 External interface circuit

	Internal circuit	No. of terminal	Signal type	Operation voltage	
Pulse input		1	A-phase pulse input 24VDC	ON	14 ~ 26.4 VDC
		2	B-phase pulse input 24VDC	OFF	Less than 2.5VDC
		3	COM		
Preset input		4	Preset input 24V	ON	19 ~ 26.4 V
		5	Preset COM	OFF	6 V or less

16.4 Wiring

16.4.1 Wiring instructions

A high speed pulse input is sensitive to the external noise and should be handled with special care. When wiring the built-in high speed counter of K3P-07CS, take the following precautions against wiring noise.

- 1) Be sure to use shielded twisted pair cables. Also provide Class 3 grounding.
- 2) Do not run a twisted pair cable in parallel with power cables or other I/O lines which may generate noise.
- 3) Before applying a power source for pulse generator, be sure to use a noise-protected power supply.
- 4) For 1-phase input, connect the count input signal only to the phase A input; for 2-phase input, connect to phases A and B.

16.4.2 Wiring examples

- 1) Voltage output pulse generator

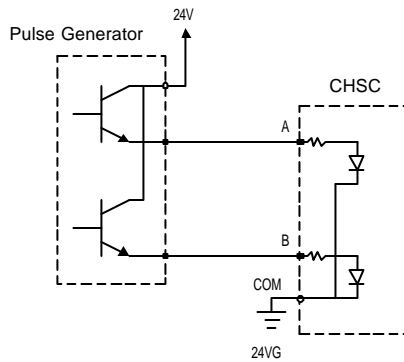

- 2) Open collector output pulse generator

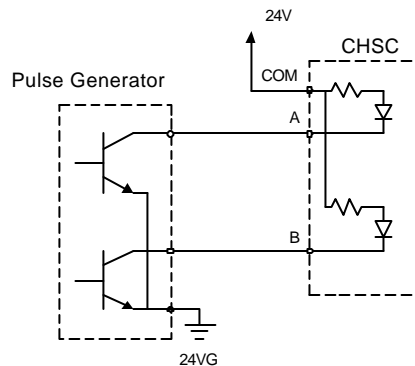

16.5 HSC instruction

16.5.1 Introduction

When use the built-in high speed counter of K200S, the HSC instruction should be used.

The instruction format of HSC is as following;

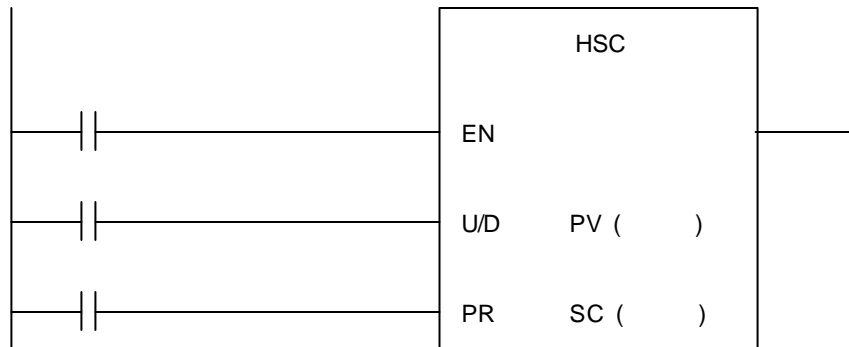

When the value of operation mode (D4999), PV or SV is not proper, the instruction error flag (F110) turns on and the HSC instruction is not executed.

1) EN input (Counter enable)

When the EN input turns on, the counter starts counting pulse. When the EN is off, the counting is stopped and the current value of high speed counter is cleared as 0.

2) U/D input (Up/down)

When the U/D input is off, the high speed counter operates as up counter. When the U/D is on, it operates as down-counter.

3) PR input (Preset)

When the PR input is on, the current value of high speed counter is replaced with the preset value (PV).

4) Output relay (F170)

The F170 bit will be turn on when the current value of high speed counter (F18 : lower word, F19 : upper word) is equal of greater than the set value (SV).

5) Carry flag (F171)

The carry flag turns on when the current value of high speed counter is underflow (0 → 16,777,215) during down counting or overflow (16,777,215) during up counting.

6) Current value

The current value of high speed counter is stored at two words, F18 and F19. The lower word is stored at F18, and upper word is stored at F19.

16.5.2 Operation mode (D4999)

Operation mode		Input terminal			Multipli- cation	Description
		A phase	B phase	Preset		
1 phase	h1000	Pulse input	–	–	–	U/D : Set by sequence program PR : Set by sequence program
	h1010	Pulse input	–	Preset input	–	U/D : Set by sequence program PR : Set by preset input
	h1100	Pulse input	U/D input	–	–	U/D : Set by U/D input PR : Set by sequence program
	h1110	Pulse input	U/D input	Preset input	–	U/D : Set by U/D input PR : Set by preset input
2 phase	h2001	A-phase input	B-phase input	–	1	PR : Set by sequence program 1 multiplication
	h2002	A-phase input	B-phase input	–	2	PR : Set by sequence program 2 multiplication
	h2004	A-phase input	B-phase input	–	4	PR : Set by sequence program 4 multiplication
	h2011	A-phase input	B-phase input	Preset input	1	PR : Set by preset input 1 multiplication
	h2012	A-phase input	B-phase input	Preset input	2	PR : Set by preset input 2 multiplication
	h2014	A-phase input	B-phase input	Preset input	4	PR : Set by preset input 4 multiplication

Remark

The U/D and PR input of sequence program must be programmed with dummy input even they are set as external input. When the PR and/or U/D is set as external input, the input conditions of sequence program is ignored.

16.6 Example of program

16.6.1 1-phase operation mode (D4999 = h1010)

- 1) U/D : set by sequence program (M001)
- 2) PR : set by external PR input
- 3) Ladder diagram

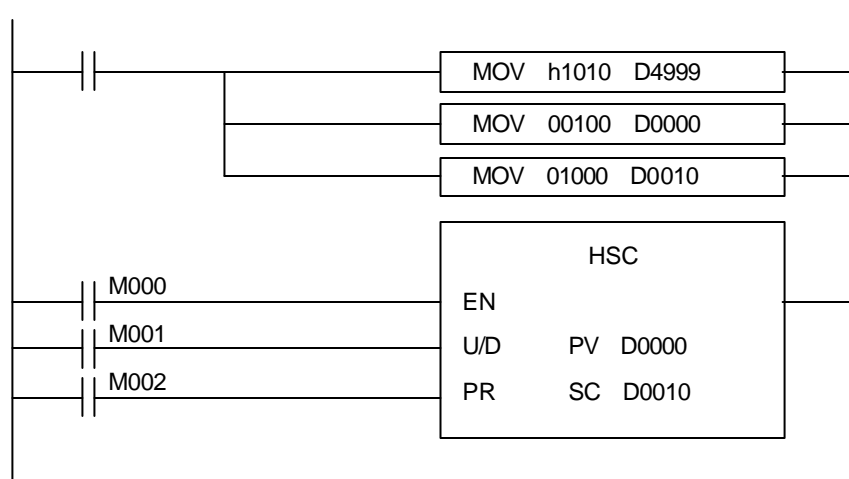

- 4) Time chart

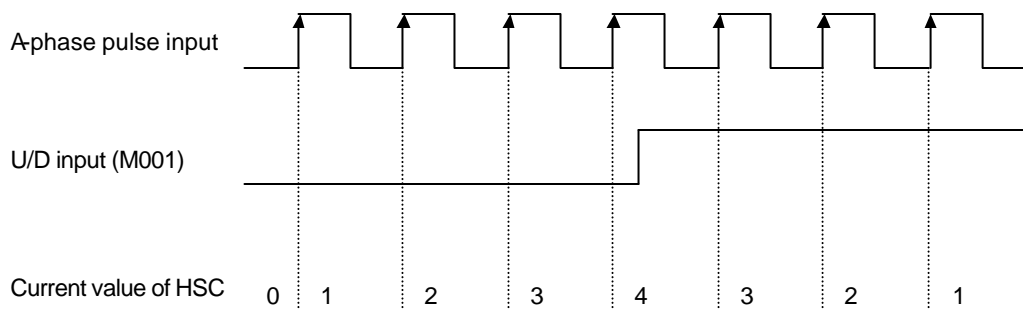

16.6.2 1-phase operation mode (D4999 = h1100)

- 1) U/D : set by external input (B-phase input)
- 2) PR : set by sequence program (M002)
- 3) Ladder diagram

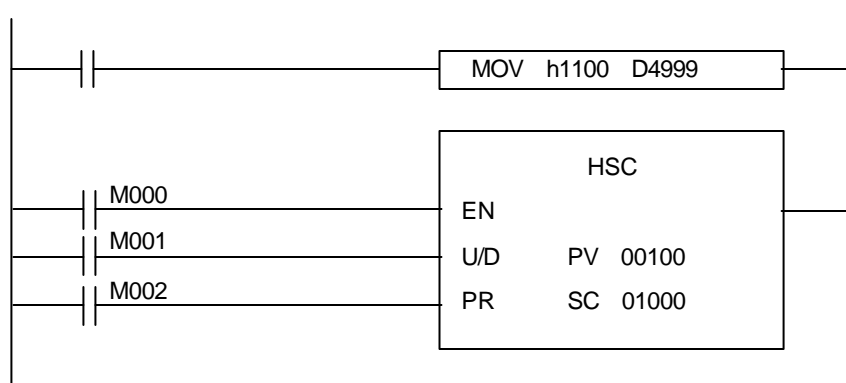

- 4) Time chart

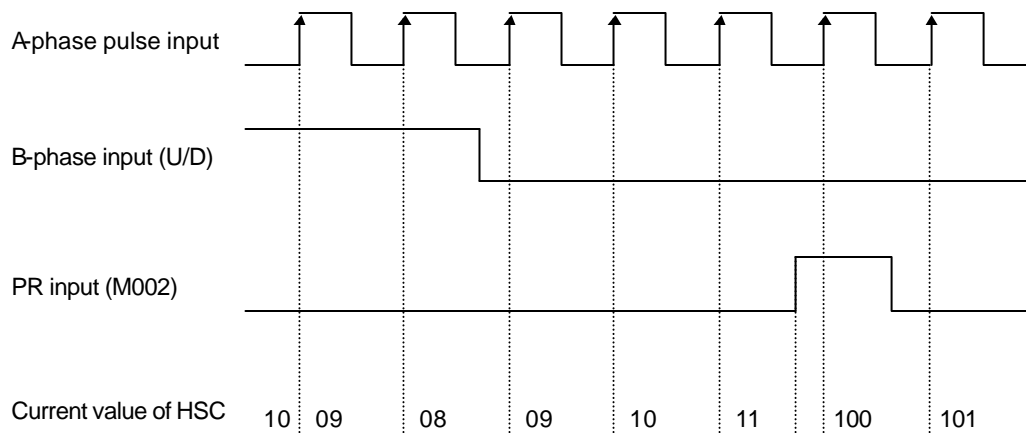

16.6.3 2-phase operation mode (D4999 = h2011)

- 1) U/D : set automatically by the phase difference between A and B phase
- 2) PR : set by external PR input
- 3) Multiplication : 1
- 4) Ladder diagram

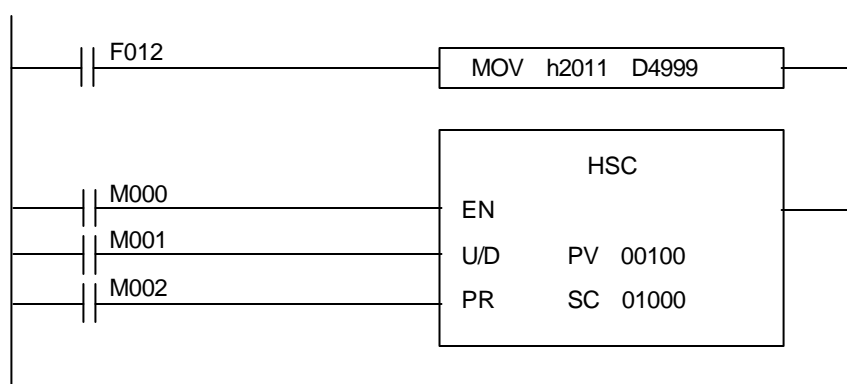

- 5) Time chart

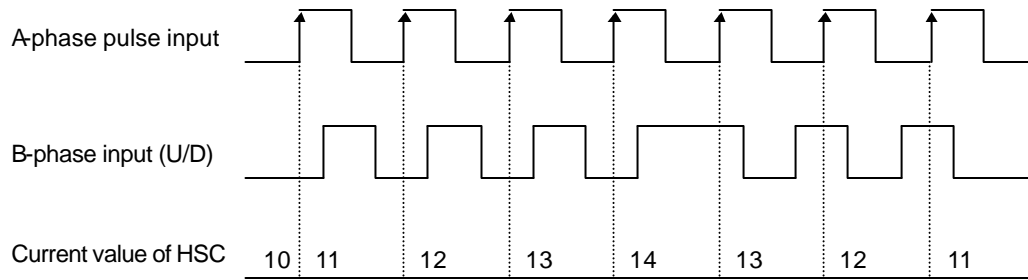

16.6.4 2-phase operation mode (D4999 = 2012)

- 1) U/D : set automatically by the phase difference between A and B phase
- 2) PR : set by external PR input
- 3) Multiplication : 2 times
- 4) Ladder diagram

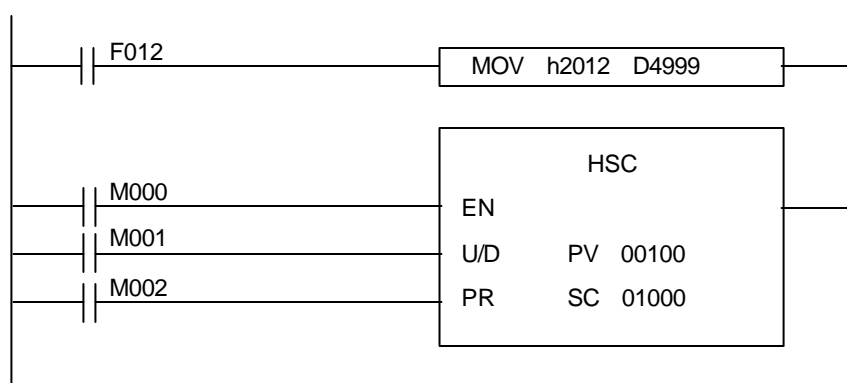

- 5) Time chart

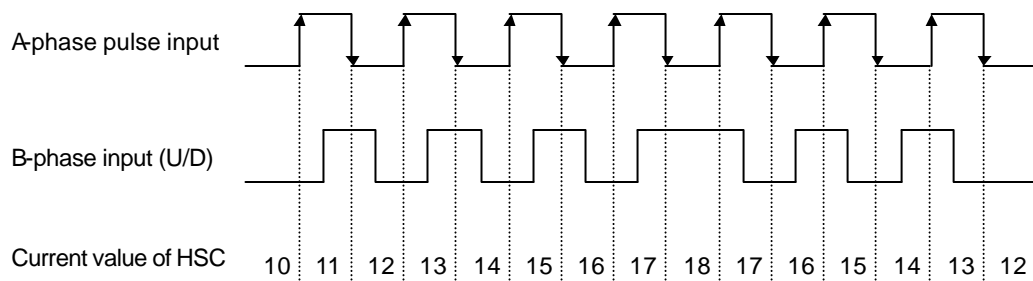

16.6.5 2-phase operation mode (D4999 = h2014)

- 1) U/D : set automatically by the phase difference between A and B phase
- 2) PR : set by external PR input
- 3) Multiplication : 4 times
- 4) Ladder diagram

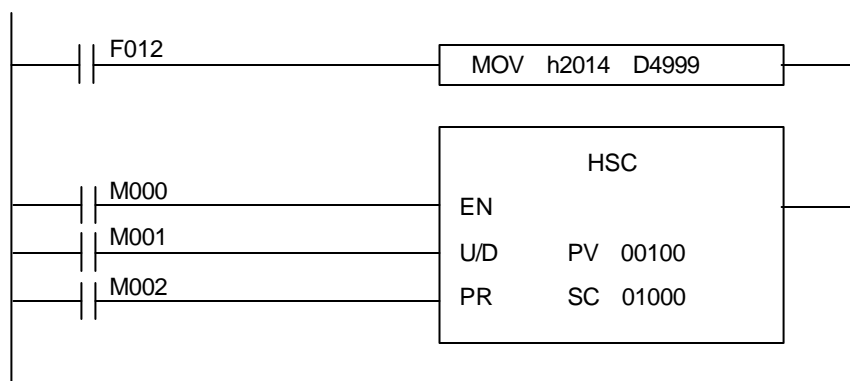

- 5) Time chart

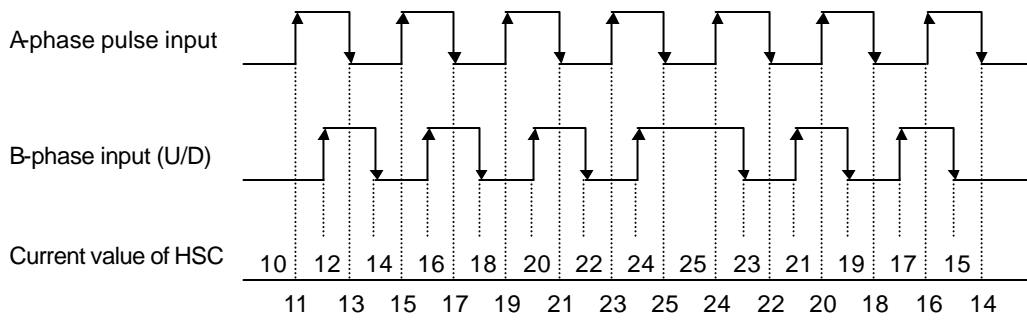

Appendix

A	Flag list.....	A-1
A1	Special relay (F/M)	A-1
A.1.1	F relay.....	A-1
A.1.2	M relay.....	A-3
A2	Special data register (D area).....	A-4
A.2.1	Flags related to communication module.....	A-4
A.2.2	Flags related to the high speed link.....	A-6
A3	Link relay (L area)	A-8
A.3.1	When Cnet module is mounted	A-8
A.3.2	When the Fnet module is mounted.....	A-9
A4	Dimension	A-10
A.4.1	CPU modules	A-10
A.4.2	I/O, special function modules.....	A-11
A.4.3	Power modules	A-12
A.4.4	Main / expansion bases	A-13

A. Flag list

A.1 Special relay (F/M)

A.1.1 F relay

Relay	Function	Description
F0000	RUN mode	Turns on when the CPU in the RUN mode.
F0001	Program mode	Turns on when the CPU in the Program mode
F0002	Pause mode	Turns on when the CPU in the Pause mode
F0003	Debug mode	Turns on when the CPU in the Debug mode
F0006	Remote mode	Turns on when the CPU in the Remote mode
F0007	User memory installation	Turns on when a user memory is installed.
F0008 and F0009	Unused	
F000A	User memory operation	Turns on when a user memory is being operated
F000B to F000E	Unused	
F000F	Execution of the STOP instruction	Turns on when the STOP instruction is being operated.
F0010	Always On	Always On
F0011	Always Off	Always Off
F0012	1 Scan On	1 Scan On
F0013	1 Scan Off	1 Scan Off
F0014	Scan toggle	Scan toggle
F0015 to F001F	Unused	
F0020	1 step run	Turns on when the 1 step run is operated in the Debug mode.
F0021	Breakpoint run	Turns on when the breakpoint run is operated in the Debug mode.
F0022	Scan run	Turns on when the scan run is operated in the Debug mode.
F0023	Coincident junction value run	Turns on when the coincident junction run is operated in the Debug mode.
F0024	Coincident word value run	Turns on when the coincident word run is operated in the Debug mode.
F0025 to F002F	Unused	
F0030	Fatal error	Turns on when a fatal error has occurred.
F0031	Ordinary error	Turns on when an ordinary error has occurred.
F0032	WDT Error	Turns on when a watch dog timer error has occurred.
F0033	I/O combination error	Turns on when an I/O error has occurred. (When one or more bit(s) of F0040 to F005F turns on)
F0034	Battery voltage error	Turns on when the battery voltage has fallen below the defined value.
F0035	Fuse error	Turns on when a fuse of output modules has been disconnected.
F0036 to F0038	Unused	
F0039	Normal backup operation	Turns on when the data backup is normal.

(Continued)

Relay	Function	Description
F003A	RTC data error	Turns on when the RTC data setting error has occurred.
F003B	During program edit	Turns on during program edit while running the program.
F003C	Program edit error	Turns on when a program edit error has occurred while running the program.
F003D to F003F	Unused	
F0040 to F005F	I/O error	When the reserved I/O module (set by the parameter) differs from the real loaded I/O module or a I/O module has been mounted or dismounted, the corresponding bit turns on.
F0060 to F006F	Storing error code	Stores the system error code, (See Section 2.9)
F0070 to F008F	Storing the disconnection state of fuses	When a fuse has disconnected in an output module, the corresponding bit to the slot turns on.
F0090	20-ms cycle clock	Turning On/Off is repeated with a constant cycle.
F0091	100-ms cycle clock	
F0092	200-ms cycle clock	
F0093	1-sec cycle clock	
F0094	2-sec cycle clock	
F0095	10-sec cycle clock	
F0096	20-sec cycle clock	
F0097	60-sec cycle clock	
F0098 to F009F	Unused	
F0100	User clock 0	Turning On/Off is repeated as many times as the scan specified by Duty instruction.
F0101	User clock 1	
F0102	User clock 2	
F0103	User clock 3	
F0104	User clock 4	
F0105	User clock 5	
F0106	User clock 6	
F0107	User clock 7	
F0108 to F010fF	Unused	
F0110	Operation error flag	Turns on when an operation error has occurred.
F0111	Zero flag	Turns on when the operation result is "0".
F0112	Carry flag	Turns on when a carry occurs due to the operation.
F0113	All outputs off	Turns on when an output instruction is executed.
F0114	Common RAM R/W error	Turns on when a memory access error of the special module has occurred.
F0115	Operation error flag (Latch)	Turns on when an operation error has occurred.(Latch)
F0116 to F011F	Unused	

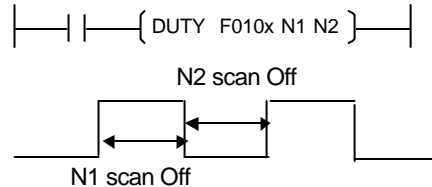
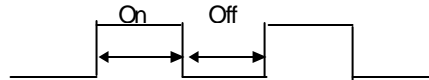

(Continued)

Relay	Function	Description
F0120	LT flag	Turns on if $S_1 < S_2$ when using the CMP instruction.
F0121	LTE flag	Turns on if $S_1 \leq S_2$ when using the CMP instruction.
F0122	EQU flag	Turns on if $S_1 = S_2$ when using the CMP instruction.
F0123	GT flag	Turns on if $S_1 > S_2$ when using the CMP instruction.
F0124	GTE flag	Turns on if $S_1 \geq S_2$ when using the CMP instruction.
F0125	NEQ flag	Turns on if $S_1 \neq S_2$ when using the CMP instruction.
F0126 to F012F	Unused	
F0130 to F013F	AC Down Count	Stores AC down counting value.
F0140 to F014F	FALS No.	The error code generated by FALS instruction is stored to this flag.
F0150 to F015F	PUT/GET error flag	When a common RAM access error of special modules has occurred an output module, the corresponding bit to the slot turns on.
F0160 to F016F	Unused	
F170	HSC output	Turns on when the current value of HSC reaches to preset value (K3P-07CS only)
F171	HSC carry flag	Turns on when carry or borrow occurs in HSC current value (K3P-07CS only)
F172 to F17F	Unused	
F180 to F19F	Current value of high speed counter	Stores the current value of high speed counter (K3P-07CS only) (F18 : lower word, F19 : upper word)
F200 to F49F	Unused	
F0500 to F050F	Maximum scan time	Stores the maximum scan time.
F0510 to F051F	Minimum scan time	Stores the minimum scan time.
F0520 to F052F	Present scan time	Stores the present scan time.
F0530 to F053F	Clock data	Clock data (year/month)
F0540 to F054F	Clock data	Clock data (day/hour)
F0550 to F055F	Clock data	Clock data (minute/second)
F0560 to F056F	Clock data	Clock data (day of the week)
F0570 to F058F	Unused	
F0590 to F059F	Storing error step	Stores the error step of the program.
F0600 to F060F	Storing FMM step	If a FMM related error has occurred, its occurrence information is stored.
F0610 to F063F	Unused	

A.1.2 M relay

Relay	Function	Description
M1904	RTC set enable	Write user RTC data to RTC area. Refer the chapter 4.5.1 for details.
M1910	Forced I/O enable	Enable the forced I/O function when the bit turns on. Refer the chapter 4.5.2 for details.

A.2 Special data register (D area)

A.2.1 Flags related to communication module

The following flags shows communication modules (Fnet/Cnet) mounted on the main base. Use can monitor those flags with the flag monitor function of KGL -WIN or use in sequence program.

The following table shows the flag list when the communication module is mounted on slot 0.

x : K200S/K300S = 4, K1000S = 9

Keyword	Address	Name	Description
_CnSTNOL _CnSTNOH	Dx500 Dx502	Communications module station No.	Indicates the number which is set on communications module station switch. Fnet : Station switch No. marked on the front of communications module.
_CnTXECNT	Dx504	Communications frame sending error	Increments by one whenever sending error of communications frame occurs. Connection condition of network is evaluated by this value.
_CnRXECNT	Dx505	Communications frame receiving error	Increments by one whenever receiving error of communications frame occurs. Connection condition of network is evaluated by this value.
_CnSVCFCNT	Dx506	Communications service processing error	Increments by one whenever communications service fails. Connection condition of network and overall communication quantity and program stability can be evaluated by this value.
_CnSCANMX	Dx507	Maximum communications scan time (unit : 1 ms)	Indicates the maximum time that is spent until every station connected to network has the token at least one time and sends a sending frame.
_CnSCANA	Dx508	Average communications scan time (unit : 1 ms)	Indicates the average time that is spent until every station connected to network has the token at least one time and sends a sending frame.
_CnSCANMN	Dx509	Minimum communications scan time (unit : 1 ms)	Indicates the minimum time that is spent until every station connected to network has the token at least one time and sends a sending frame.
_CnLINF	Dx510	Communications module system information	Indicates operation state of communications module with a word.
_CnCRDER	Dx510.B	System error (error = 1)	Indicates communications module hardware or system O/S error.
_CnSVBSY	Dx510.C	Insufficient common RAM (Insufficient = 1)	Indicates that service cannot be offered due to insufficient common RAM.
_CnIFERR	Dx510.D	Interface error (error = 1)	Indicates that interface with communications modules has been stopped.

(Continued)

Keyword	Address	Name	Description
_CnINRING	Dx510.E	In-ring (IN_RING = 1)	Indicates that the communications module can communicate with other station or not.
_CnLNKMOD	Dx510.F	Operation mode (RUN=1)	Indicates that operation mode of communications module is in the normal operation mode or test mode.
_CnVERNO	Dx680	Version No. of communications module	O/S version No. of communications module
_FSMn_ST_NO	Dx690	Numbers of remote I/O stations. (Write is enabled)	Sets the remote I/O station number to the upper 8 bits. (See REMARK given in the below)
_fsmn_RESET	Dx690.0	Remote I/O station S/W reset	Initializes special modules and I/O modules in the remote station defined by the FSMn_st_no.
_fsmn_IO_RESET	Dx690.1	Remote I/O station digital output reset	Clears the output of I/O modules in the remote station defined by the FSMn_st_no.
_fsmn_IO_RESET	Dx690.2	Initialize the high speed link information of remote I/O station	If a momentary power failure occurs in the remote I/O station, the operation mode bit of high speed link information turns off and link trouble has the value 1. If the bit is turned on to clear that bit, the operation mode bit turns on and link trouble is cleared with 0.

Remark

- 1) When the communication module is mounted on other slot than slot 0, please calculate the device number of flag with the following table.
- 2) If the _FSMn_st_no is set as hFF, the setting of _FSMn_reset, _FSMn_IO_reset, and _FSMn_hs_reset is applied to all remote stations that are linked with the communication module on the slot n.
- 3) In the _CnVERNO flag, the version numbers of communication mounted on the slot 0 to 7 are stored in order. (slot 0:Dx680, slot 1:Dx681, ..., slot 7:Dx687)

Slot No. & Flag List

Slot No.	D area address	Remark
1	Dx511 to Dx521	The address of the flag which is loaded onto the slot n is calculated as shown below. * Address of D area = Address shown in the [TABLE1] + 11 × n, (where n = 1 to 7) Example) Address for the average communications scan time of the communications module loaded on the slot 6. → Dx508 + 11 × 6 = Dx574
2	Dx522 to Dx532	
3	Dx533 to Dx543	
4	Dx544 to Dx554	
5	Dx555 to Dx565	
6	Dx566 to Dx576	
7	Dx577 to Dx587	

A.2.2 Flags related to the high speed link

The following table shows the flags when the m is 0.

x : K200S/300S = 4, K1000S = 9

m : the number of high speed link setting

Keyword	Bit Address	Name	Description
_HSmRLINK	Dx600.0	High speed link normal run information(RUN_LINK)	<p>Indicates that all stations are normally operating complying with the parameter set in the high speed link. This flag turns on under the following conditions.</p> <ol style="list-style-type: none"> 1. All stations set in the parameter are in the RUN mode and have no error, and 2. All blocks set in the parameter normally communicate, and 3. The parameters set in all stations, which are set in the parameter, normally communicate. <p>Once this flag is turned on, it maintains that state as long as link disable does not make that state stopped.</p>
_HSmLTRBL	Dx600.1	High speed link trouble abnormal run information	<p>This flag turns on when, under the condition that _HSmRLINK is turned on, communications of the stations and data blocks set in the parameter is under the following conditions.</p> <ol style="list-style-type: none"> 1. A station set in the parameter is not in the RUN mode, or 2. A station set in the parameter has an error, or 3. The communications of data blocks set in the parameter does not normally operate. <p>This flag turns on if the above conditions 1), 2) and 3) occur. If normal conditions are restored, it will turn off again.</p>
_HSmSTATE[k] (k = 0 to 63)	Dx601.0 to Dx604.15	Overall communications state information of K Data Block set by the high link parameter	Indicates overall communications state of every blocks of the parameters set. _HSmSTATE[k] = _HSmMOD[k] & _HSmTRX[k] & _HSmERR[k]
_HSmMOD[k] (k = 0 to 63)	Dx605.0 to Dx608.15	K Data Block setting stations mode information. (RUN = 1, others = -0)	Indicates the operation modes of stations set the K data block of parameters.
_HSmTRX[k] (k = 0 to 63)	Dx609.0 to Dx612.15	K Data Block communications state information (Normal = 1, abnormal = 0)	Indicates whether communications of the K data block of parameters are normally operating as set .
_HSmERR[k] (k = 0 to 63)	Dx613.0 to Dx616.15	K Data Block setting stations state information. (Normal = 1, abnormal = 0)	Indicates whether the stations set in the K data block of parameters have an error.

Remark

The 'k' indicates the number of block. The status of 16 block is stored in a word. Therefore, total 4 words are used for storing the status of 64 blocks (k: 0 ~ 63). For example, the status of mode status of block 55 is stored in the Dx608.7 bit.

The device number of flags when m is 1 ~ 3

High Speed Link Type	D area Address	Remark
High Speed Link 2 (m=1)	Dx620 to Dx633	Compared to the D area addresses shown in the [TABLE 3], where m = 0, they are calculated as shown below where m = 1 to 3. * Address of D area = Address shown in the [TABLE3] + 11 × m, where n = 1 to 3
High Speed Link 3 (m=2)	Dx640 to Dx653	
High Speed Link 4 (m=3)	Dx660 to Dx673	

A.3 Link relay (L area)

The L area is used when the computer link module (Cnet) or data link module (Fnet) is mounted on the system. See the user's manual of Cnet or Fnet for detail information.

A.3.1 When Cnet module is mounted

(When the Cnet module is mounted on the slot 0)

Slot	Protocol	Data receiving area				
0	RS-232C	L0000 (1 st frame)	L0001 (2 nd frame)	...	L000E (15 th frame)	L000F (16 th frame)
		L0010 (17 th frame)	L0011 (18 th frame)	...	L001E (31 st frame)	L001F (32 nd frame)
		L0020 (33 rd frame)	L0021 (34 th frame)	...	L002E (47 th frame)	L002F (48 th frame)
		L0030 (49 th frame)	L0031 (50 th frame)	...	L003E (63 rd frame)	L003F (64 th frame)
	RS-422	L0040 (1 st frame)	L0041 (2 nd frame)	...	L004E (15 th frame)	L004F (16 th frame)
		L0050 (17 th frame)	L0051 (18 th frame)	...	L005E (31 st frame)	L005F (32 nd frame)
		L0060 (33 rd frame)	L0061 (34 th frame)	...	L006E (47 th frame)	L006F (48 th frame)
		L0070 (49 th frame)	L0071 (50 th frame)	...	L007E (63 rd frame)	L007F (64 th frame)

Remark

If the Cnet module is mounted on other slot than slot 0, please refer the following formula to calculate the device number of L area.

Link relay number of RS-232C : $L = (80 \times n) + [\text{the hexadecimal value of } (m - 1)]$

Link relay number of RS-422 : $L = (80 \times n) + [\text{the hexadecimal value of } (m - 1)] + 40$

where, n : slot number on which the Cnet module is mounted. (0 ~ 7)

m : frame number (1 ~ 64)

A.3.2 When the Fnet module is mounted

x : slot number

n : station number of other station

Device number	Key word	Description
L0000 ~ L003F	_NETx_LIV[n]	This flag indicates that the other station on network are active or not. (read only)
L0040 ~ L007F	_NETx_RST[n]	This flag indicates turns on when the communication with a station is recovered from malfunction (read & write)

Remark

When the Fnet module is mounted on slot 1 ~ 7, the device number of link relay can get by adding $80 \times \text{slot number}$ to the device number when the slot number is 0.

A.4 Dimension

Unit : mm

A.4.1 CPU modules

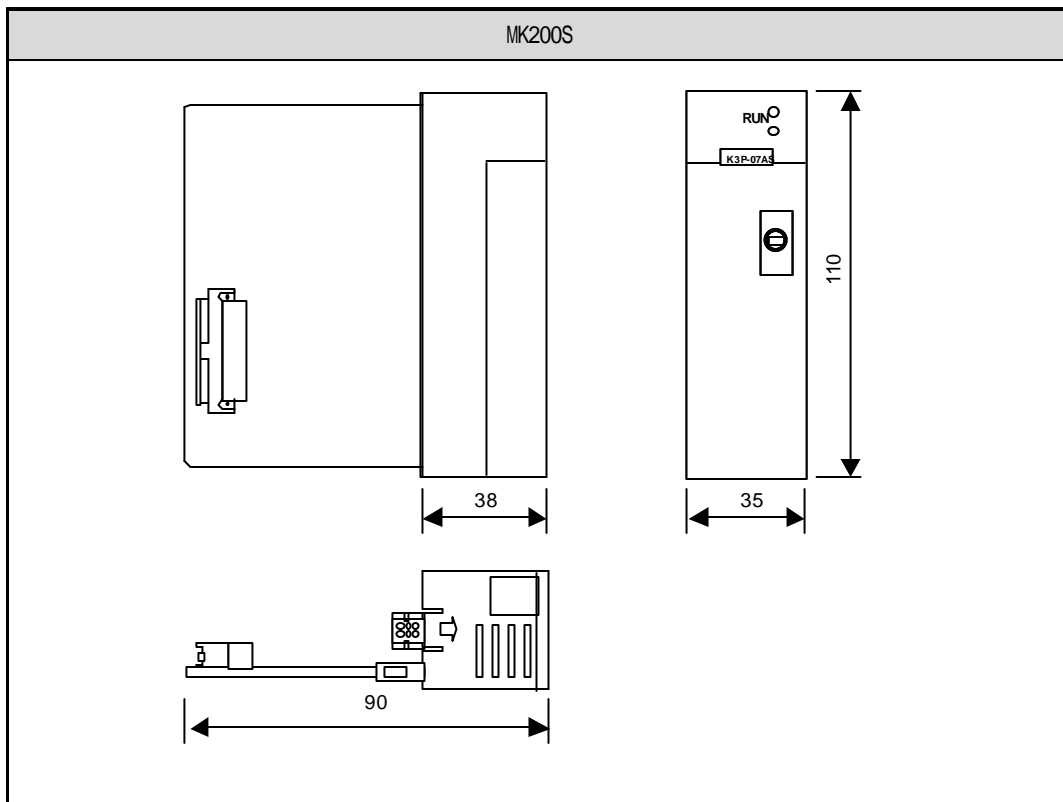
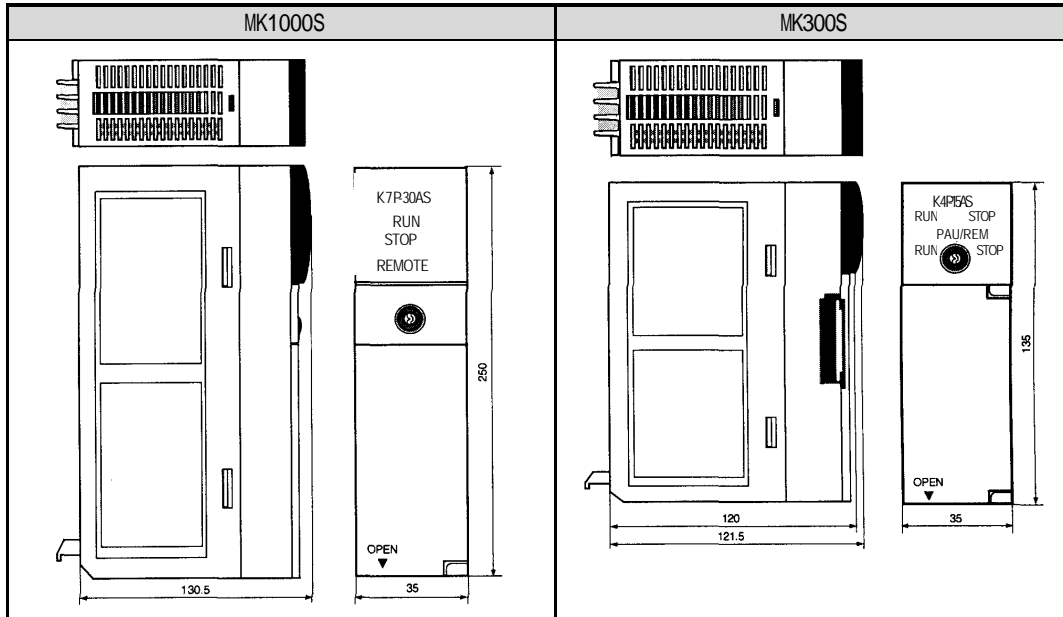

A.4.2 I/O, special function modules

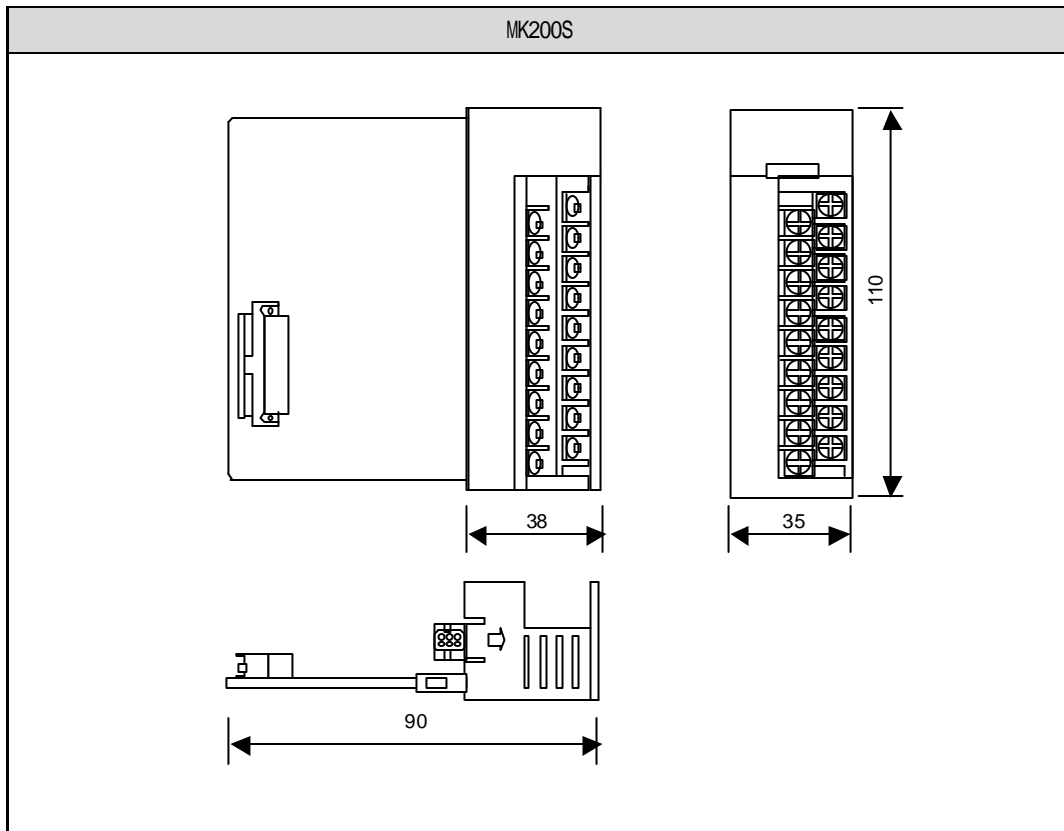
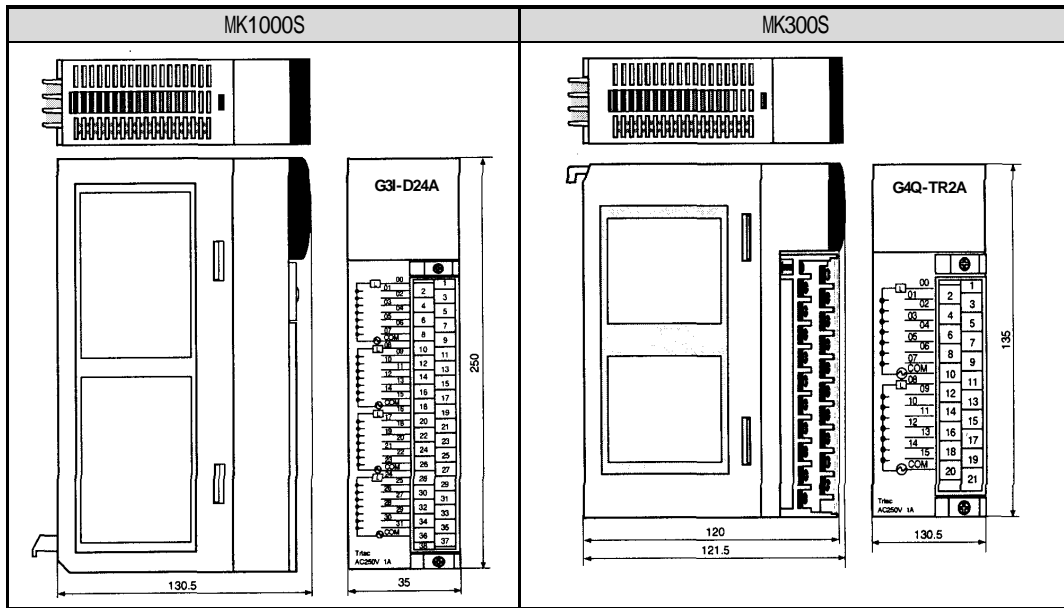

A.4.3 Power modules

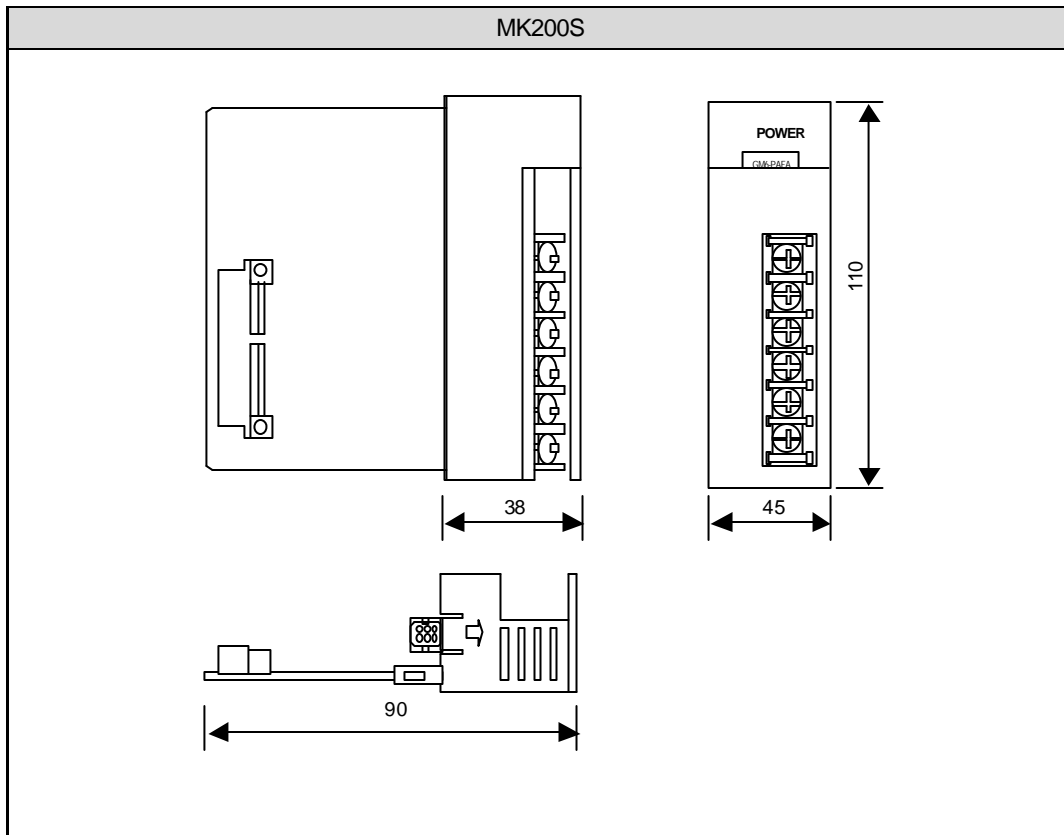
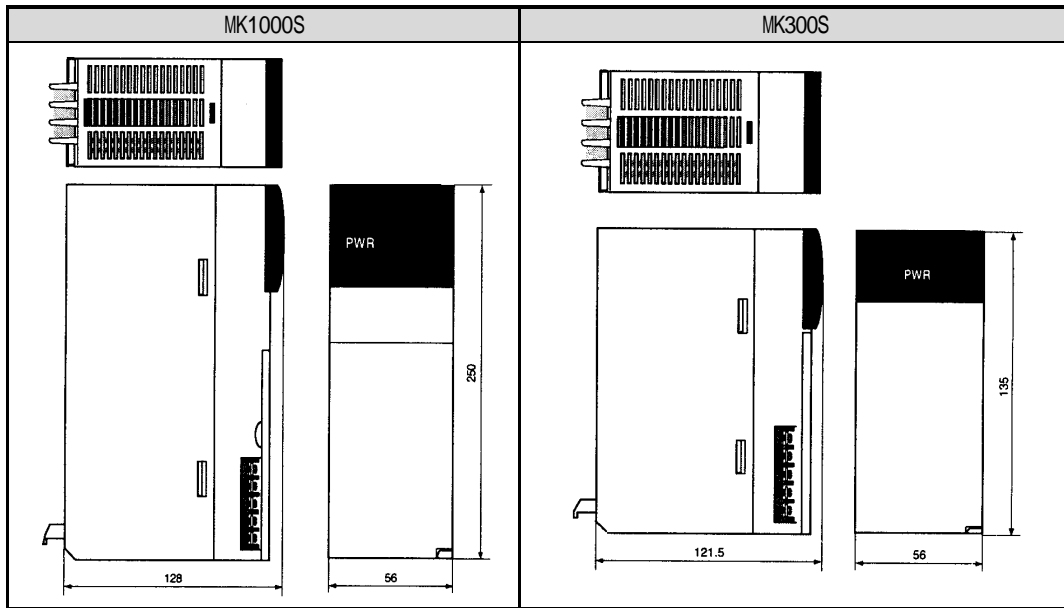

A.4.4 Main / expansion bases

